



Electric Stacker PS E12

Electric Stacker PS B12

Electric Stacker PS B15

# SPAREPARTS LIST

## Electric Stacker PS E12

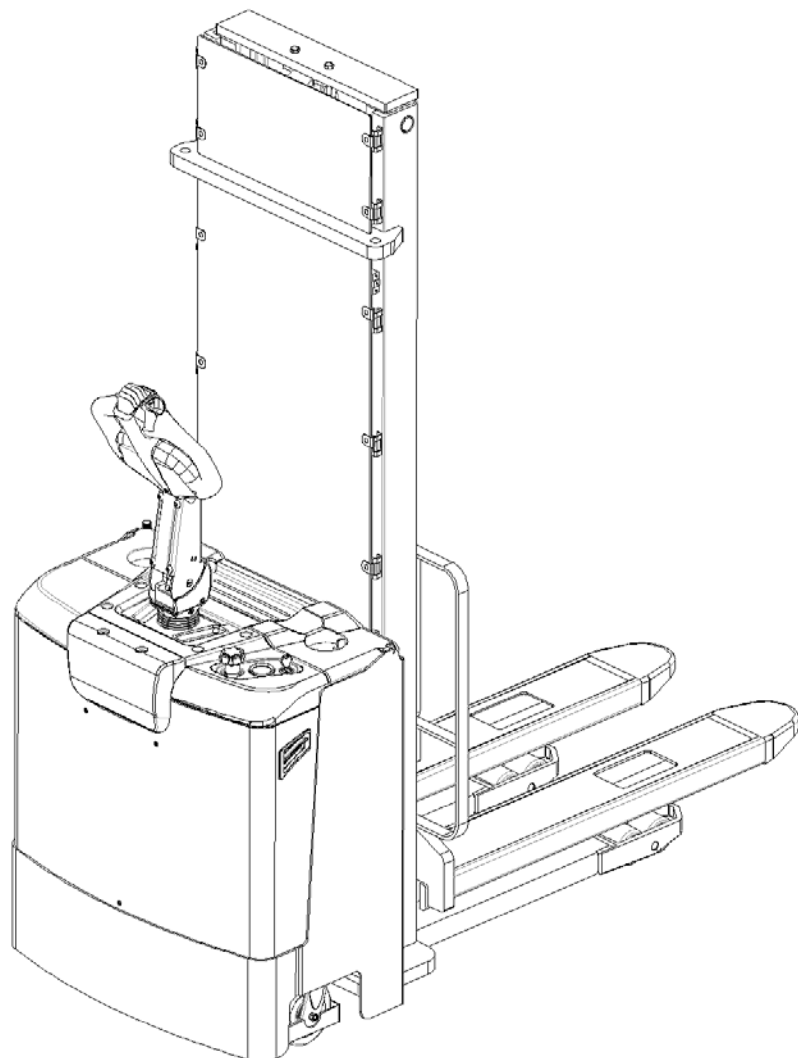

Version 10/2014

From truck identification number:

30130700011

PS E12-BPT-004-EN

# Catalogue

Fig. 1 Label (for EU) .....	2
Fig. 2 Label (for US) .....	3
Fig. 3 Outline .....	4
Fig. 4 Battery cover assembly.....	6
Fig. 5 Chassis .....	16
Fig. 6 Steering wheel .....	17
Fig. 7 Load wheel .....	19
Fig. 8 Mast assembly(PS E12S One-stage mast).....	20
Fig. 9 Mast assembly(PS E12D Two-stage mast Lift) .....	22
Fig. 10 Mast assembly(PS E12F Two-stage mast Full-Free-Lift).....	24
Fig. 11 Electronic control assembly(manual steering).....	26
Fig. 12 Main harness(manual steering).....	28
Fig. 13 Electric parts(manual steering) .....	29
Fig. 14 Power supply assembly .....	31
Fig. 15 Hydraulic system(PS E12S One-stage mast) .....	33
Fig. 16 Cylinder(PS E12S One-stage mast) .....	35
Fig. 17 Pump system .....	37
Fig. 18 Hydraulic system(PS E12D Two-stage mast Lift).....	39
Fig. 19 Cylinder(PS E12D Two-stage mast Lift).....	41
Fig. 20 Hydraulic system(PS E12F Two-stage mast Full-Free-Lift).....	43
Fig. 21 Cylinder(PS E12F Two-stage mast Full-Free-Lift).....	47
Fig. 22 Drive system(manual steering) .....	49
Fig. 23 Drive wheel(43EL) .....	51
Fig. 24 Instrument components .....	55
Fig. 25 Tiller arm assembly .....	57
Fig. 26 Tiller head .....	59
Easy worn parts list.....	61

Fig. 1 Label (for EU)

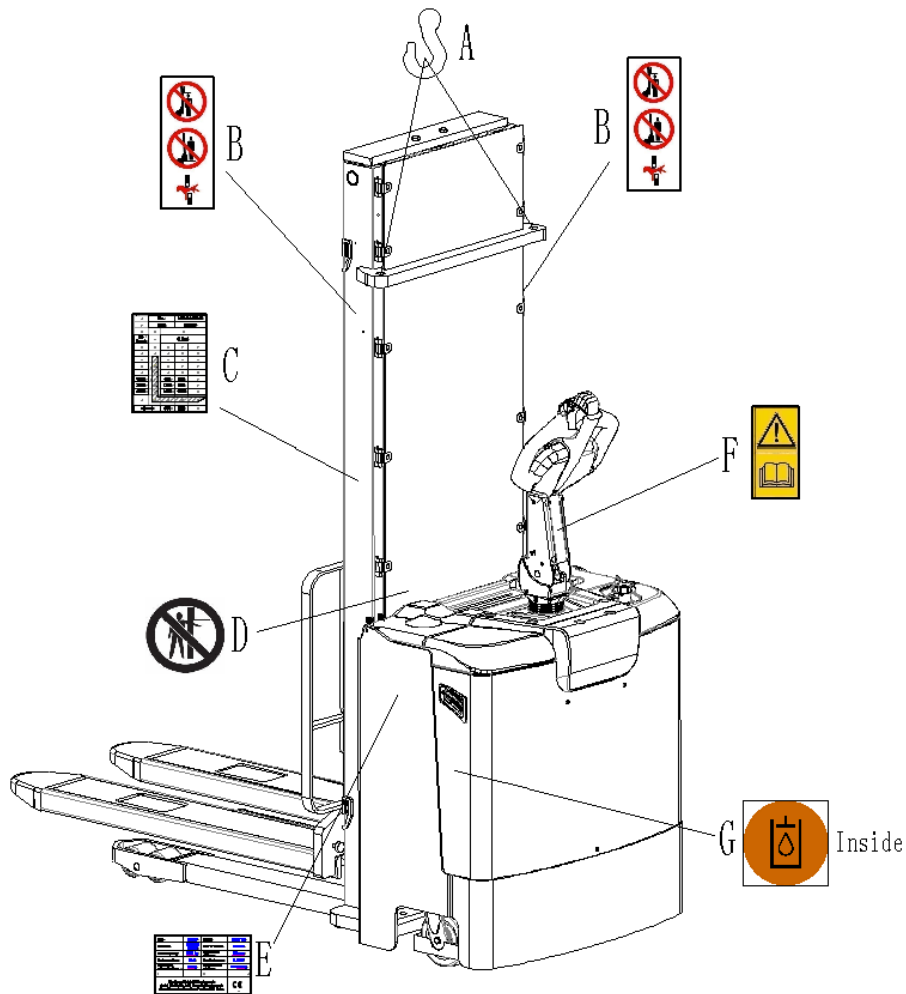

Fig. 1 Label (for EU)

No.	Parts No.	Item	Qty.	Note	Standard
A	900005967	Crane hook label	2		
B	900003923	Warning decal: Do not step under or on the forks	2		
C	900008664	Residual lift capacity sticker	1		
D	900008561	Never reach through	1		
E	900008663	Identification plate	1		
F	900003570	Sticker to read and follow these instructions	1		
G	900008555	Filling sticker	1		

Fig. 2 Label (for US)

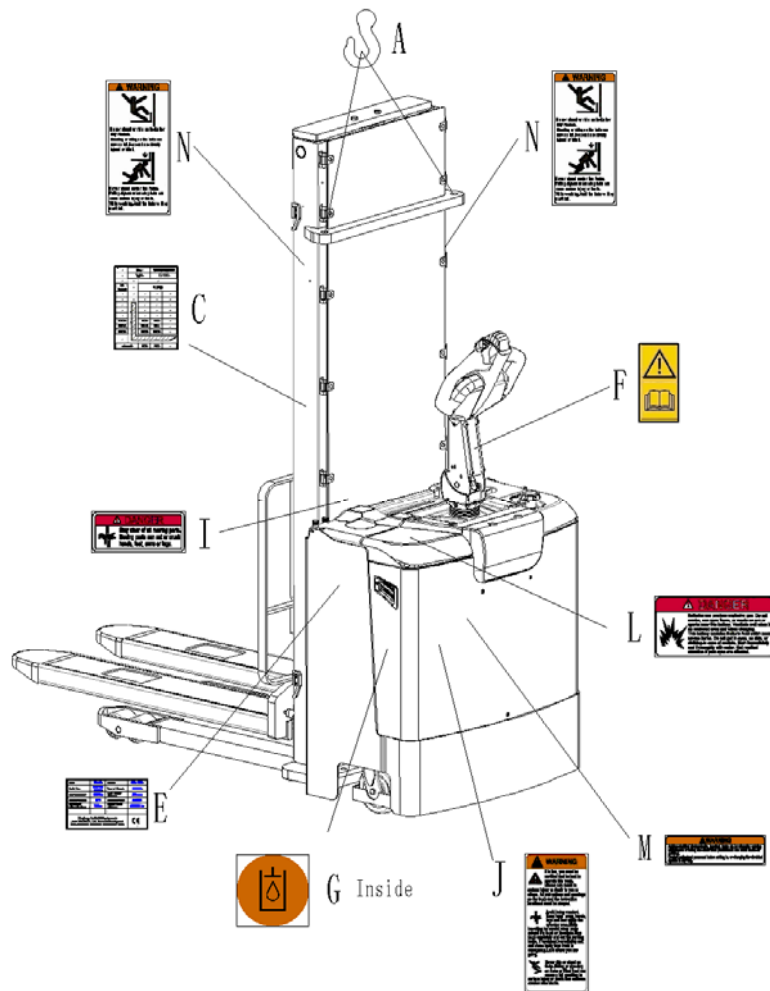
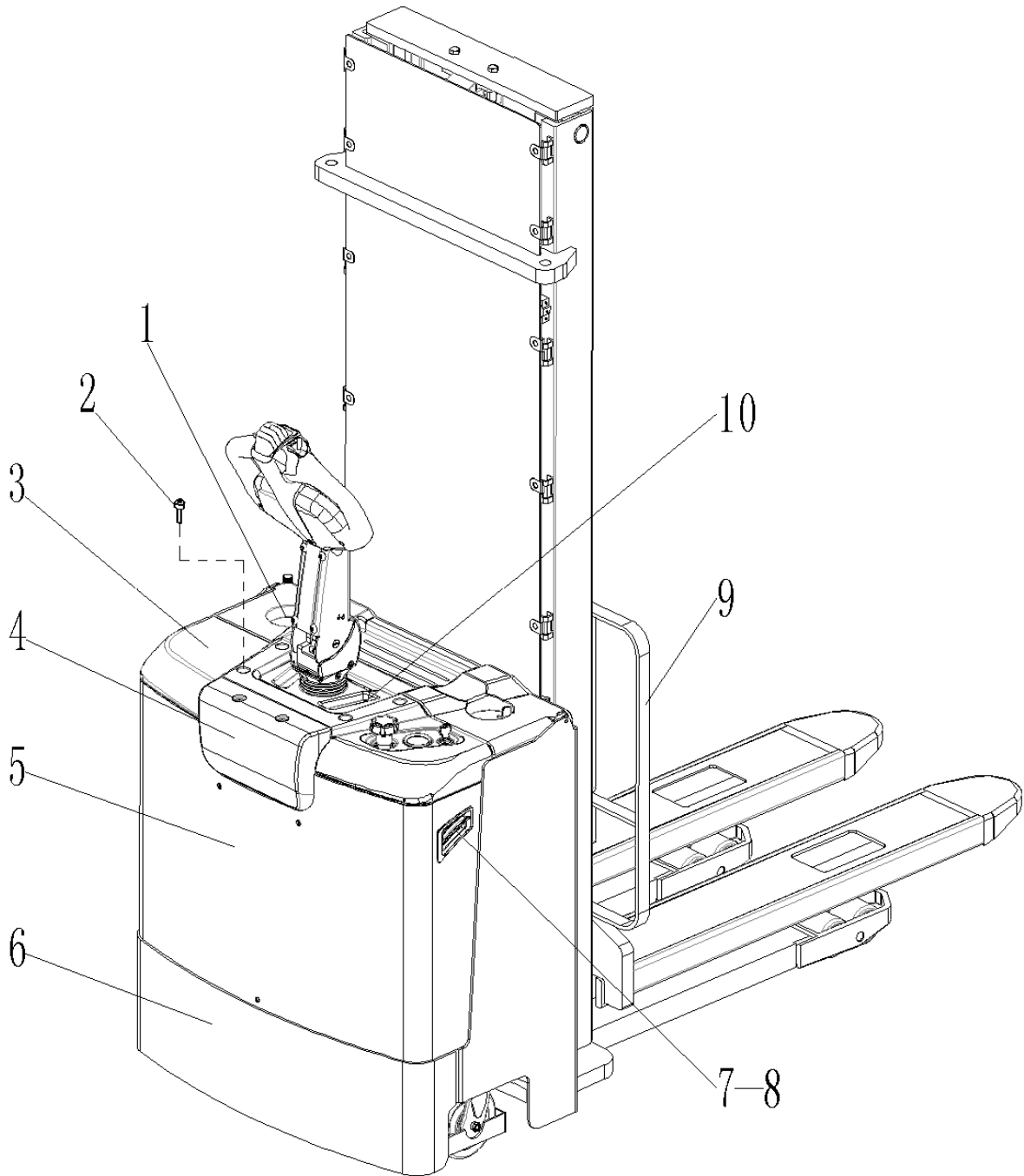

Fig. 2 Label (for US)

No.	Parts No.	Item	Qty.	Note	Standard
A	9000005967	Crane hook label	2		
C	9000008664	Residual lift capacity sticker	1		
E	9000008663	Identification plate (ID-plate)	1		
F	9000003570	Sticker to read and follow these instructions	1		
G	9000008555	Filling sticker	1		
I	9000005970	Warning label	1		
J	9000003575	Warning label	1		
L	9000003577	Warning label	1		
M	9000003579	Warning label	1		
N	9000005971	Warning label	2		

Fig. 3 Outline



**Fig. 3 Outline**

No.	Art No.	Description	Qty.	Note	Standard
1	9000008128	Battery cover	1		
2	1000423003	Screw	8	M10×30	
3	9000008129	Upper cover	1		
4	9000008064	Without protective arm cover	1	LPT20E.3-5/01	
5	9000008126	Welded main cover	1		
6	9000008125	Welded truck body	1		
7	9000007920	Left vent components	1		
8	9000007923	Right vent components	1		
9	9000008259	Load backrest assembly	1		
10	9000008130	Middle cover	1		

Fig. 4 Battery cover assembly

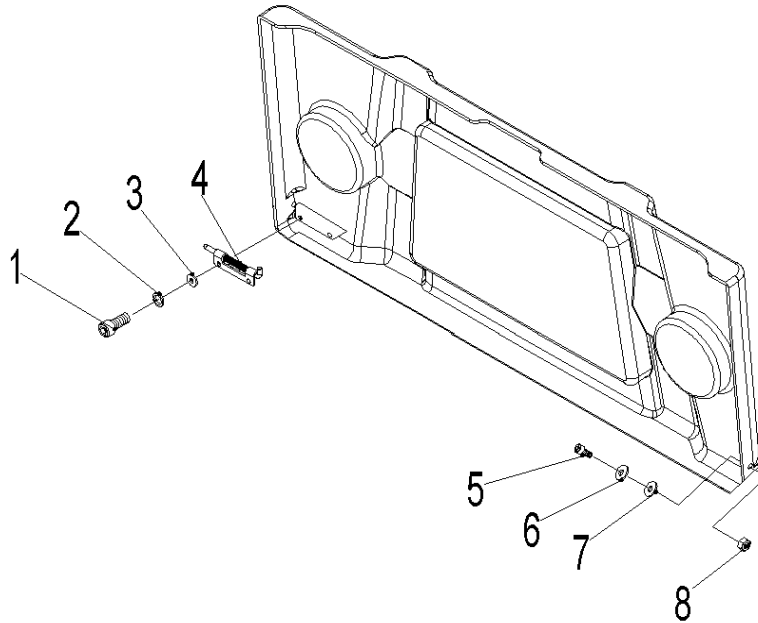

Fig. 4 Battery cover assembly

No.	Art No.	Description	Qty.	Note	Standard
1	0000023073	Screw	2	M4×10	GB/T70.1=ISO4762
2	0000025018	Washer	2	4	GB/T93
3	0000025019	Washer	2	4	GB/T95
4	9000008795	Bolt	1	CL037	
5	0000023306	Screw	1	M5×20	GB/T70.1=ISO4762
6	0000025015	Washer	1	5	GB/T93
7	0000025014	Washer	1	5	GB/T95
8	0000024035	Nut	1	M5	GB/T6170



Fig. 5 Chassis

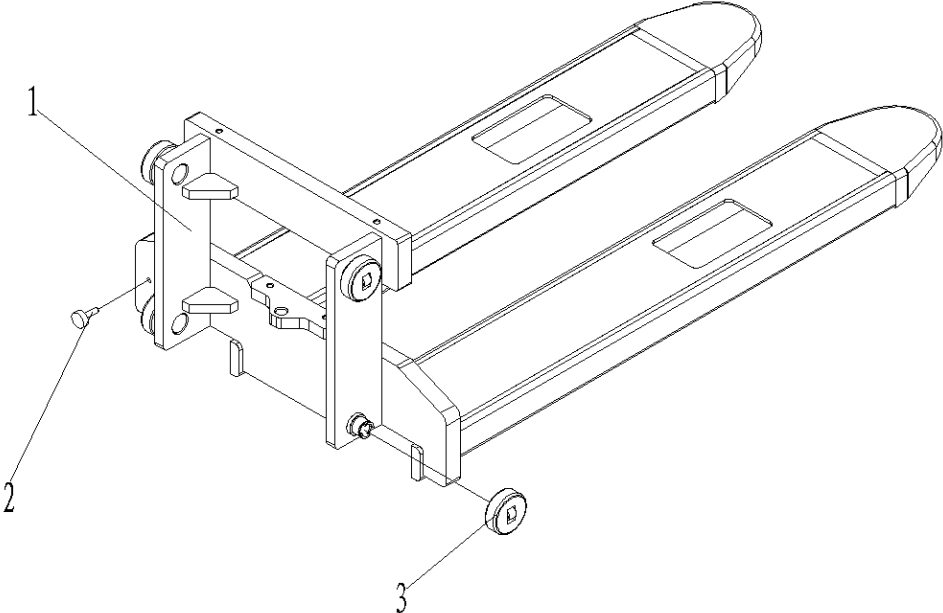
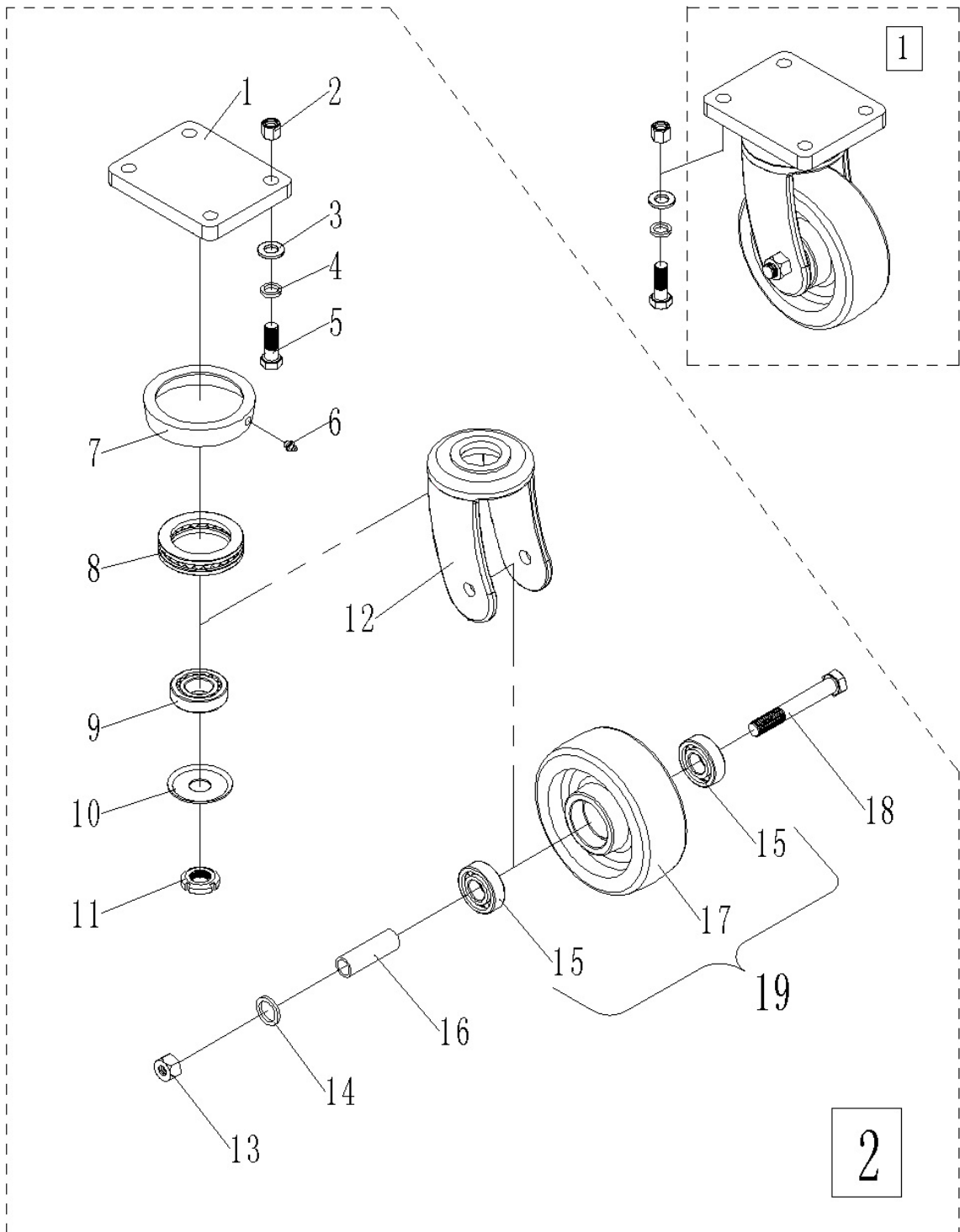

Fig. 5 Chassis

No.	Art No.	Description	Qty.	Note	Standard
1	9000009351	Welded chassis (570X1150)	1	one-stage mast	
	9000009352	Welded chassis (685X1150)	1	one-stage mast	
	9000008108	Welded chassis (570X1150)	1	two-stage mast	
	9000009144	Welded chassis (685X1150)	1	two-stage mast	
2	2000435002	Magnet steel	1		
3	9000007754	Compound roller	4		

Fig. 6 Steering wheel



**Fig. 6 Steering wheel**

No.	Art No.	Description	Qty.	Note	Standard
1	2240401006	Welded flange	2		
2	0000024006	Lock nut	8	M12	GB/T889.1=ISO7040
3	0000025032	Washer	8	12	GB/T95
4	0000025024	Washer	8	12	GB/T93
5	0000023122	Screw	8	M12×50	GB/T70.1=ISO4762
6	0000030002	Oil cup	2	M6	JB/T7940.1
7	2210422001	Dust ring	2		
8	0000027014	Bearing	2	8111	GB/T301
9	0000027015	Bearing	2	7205E	GB/T297
10	2210404001	Pressure cover	2		
11	0000024016	Round nut	2	M20×1.5	GB/T812
12	2210405001	Frame of roller	2		
13	0000024015	Lock nut	2	M14	GB/T889.1=ISO7040
14	2210425001	Washer	4		
15	0000027001	Bearing	4	6204	GB/T276=ISO3290
16	2210413001	Shaft sleeve	2		
17	2210416001	Castor	2		
18	0000023111	Bolt	2	M14×100	GB/T5782=ISO4014
19	9000008896	Wheel set	1		
①	2210400001	Welded castor	2		
②	9000010410	Steering wheel kit	2		

Fig. 7 Load wheel

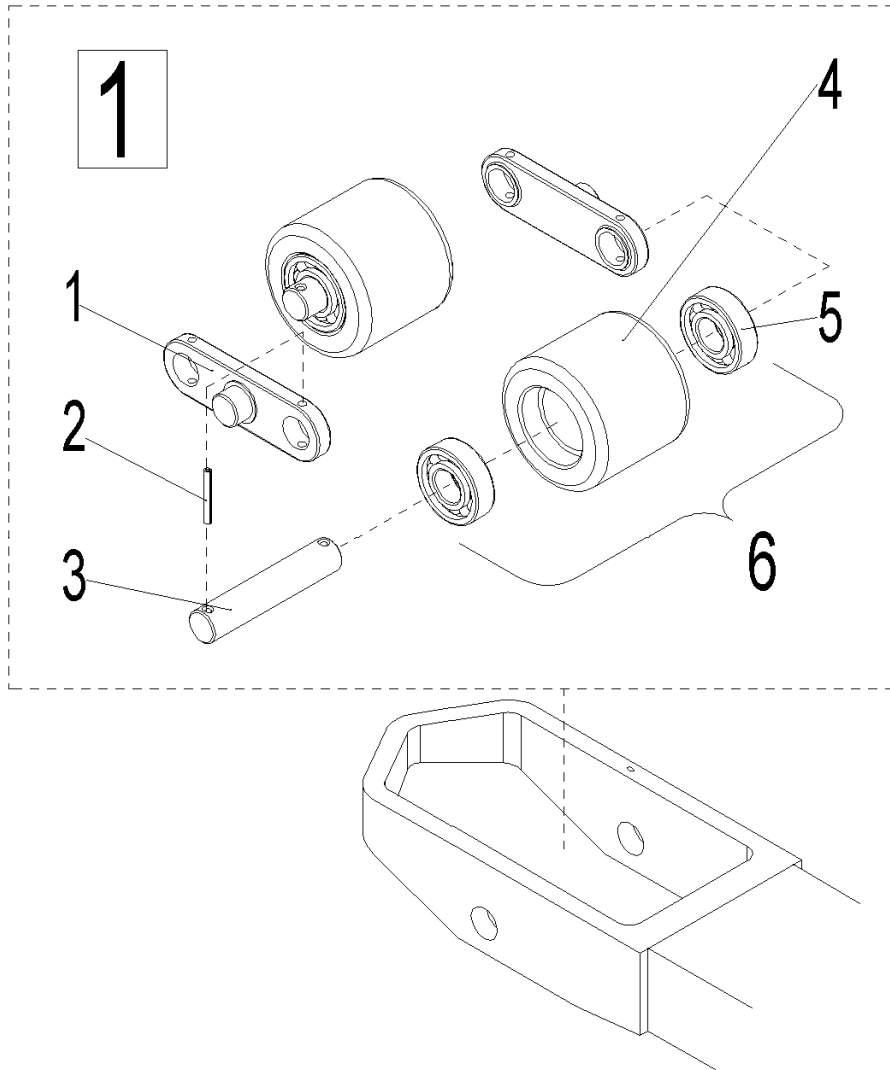
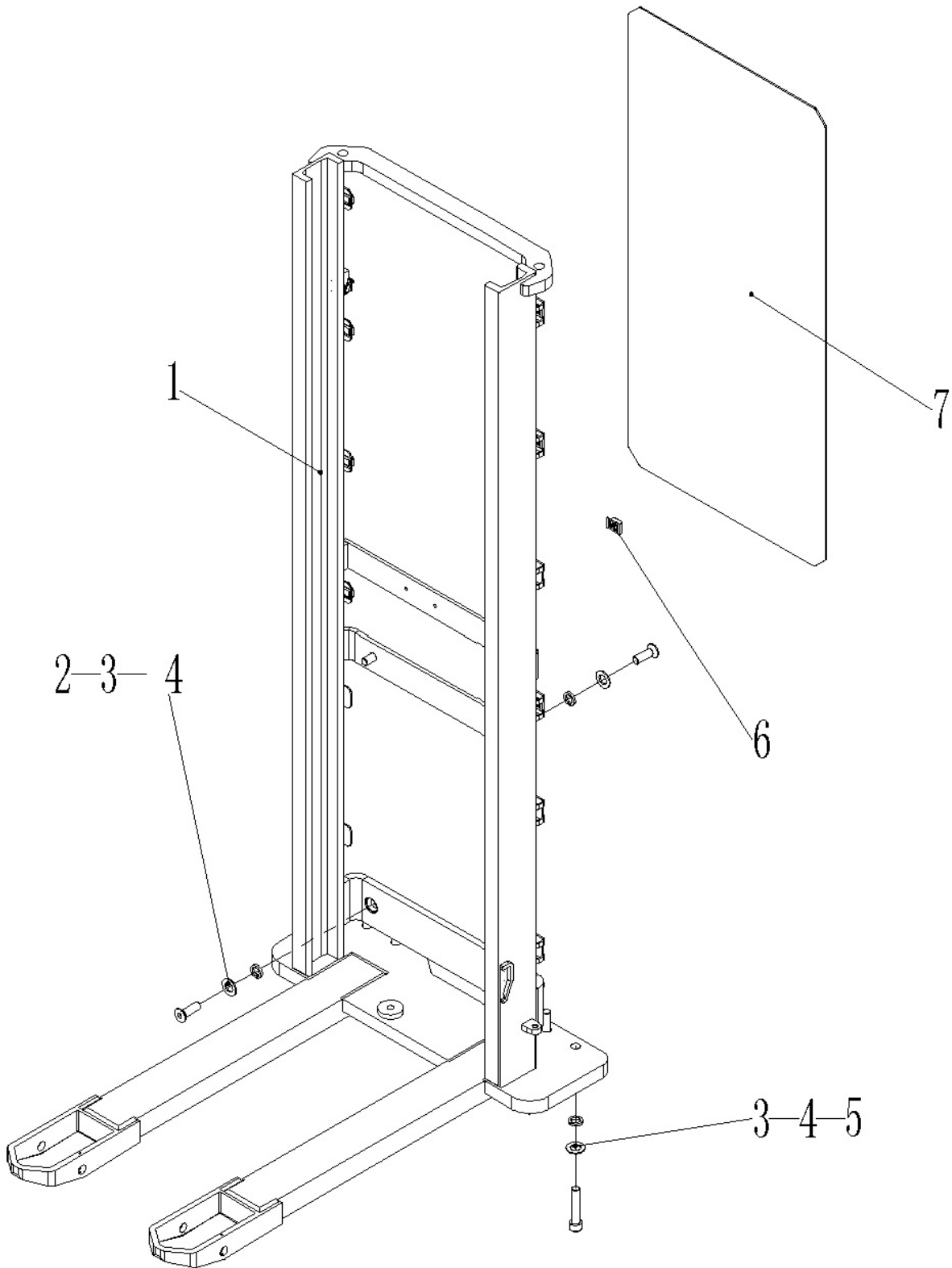

Fig. 7 Load wheel

No.	Art No.	Description	Qty.	Note	Standard
1	2000405002	Connecting plate	2		
2	0000028009	Dowel pin	4	∅5×35	GB/T879.1
3	2000407001	Shaft for load roller	2		
4	2000416002	Load roller	2	∅80×70	
5	0000027001	Bearing	4	6204	GB/T276=ISO3290
6	9000010398	Wheel set	2		
①	2000600001	Load roller assembly	2		

Fig. 8 Mast assembly(PS E12S One-stage mast)



**Fig. 8 Mast Assembly(PS E12S One-stage mast)**

No.	Art No.	Description	Qty.	Note	Standard
1	9000009353	Welded mast	1	1600;570×1150	
	9000009354	Welded mast	1	1600;685×1150	
2	2210423001	Screw	4	M16×52	
3	0000025029	Washer	8	16	GB/T95
4	0000024011	Lock nut	8	M16	GB/T889.1=ISO7040
5	0090000486	Screw	4	M16×80	GB/T70.1=ISO4762
6	9000007782	Spring buckle	8	1	
7	9000009355	Protective glass	1	1600	

Fig. 9 Mast assembly(PS E12D Two-stage mast Lift)

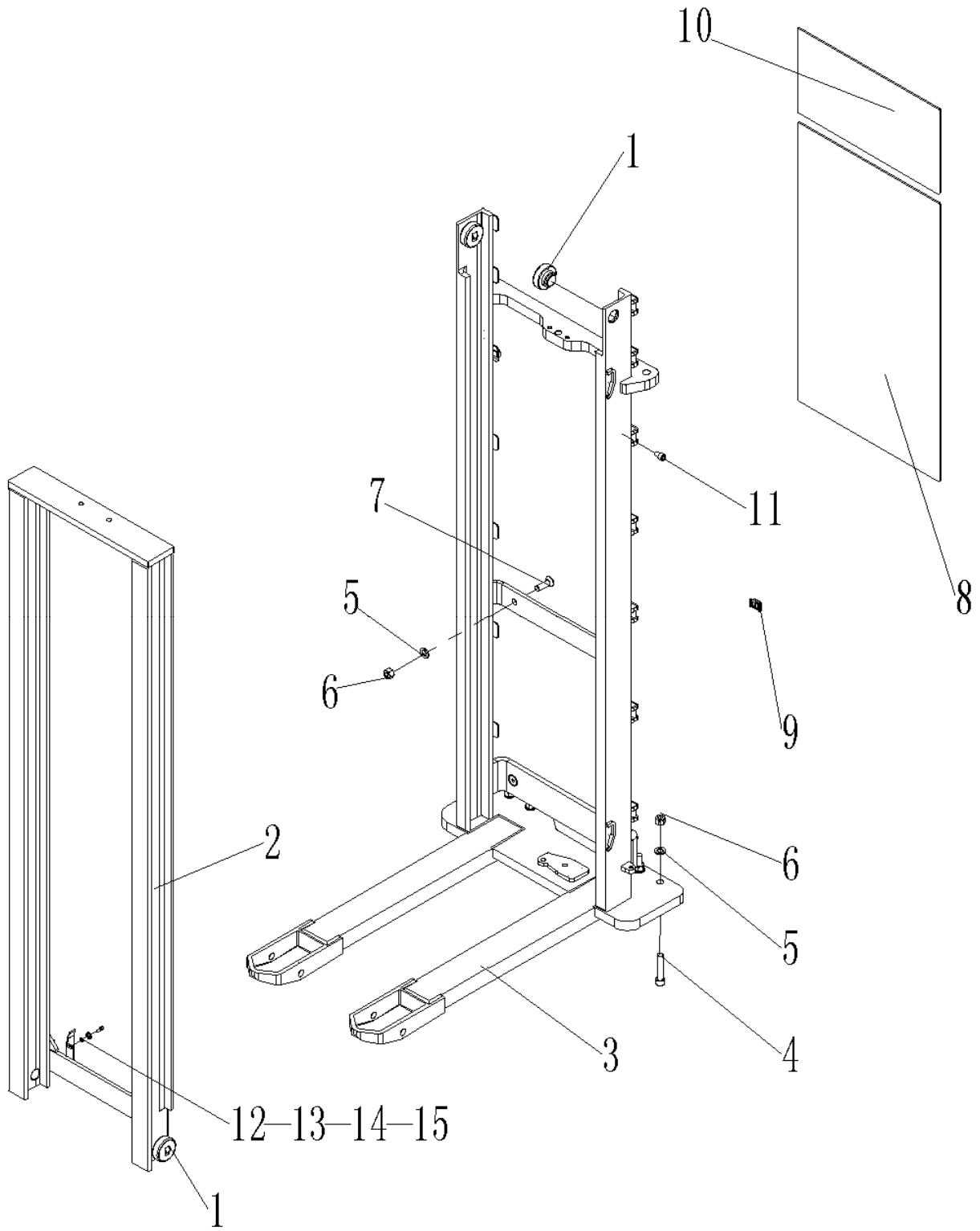
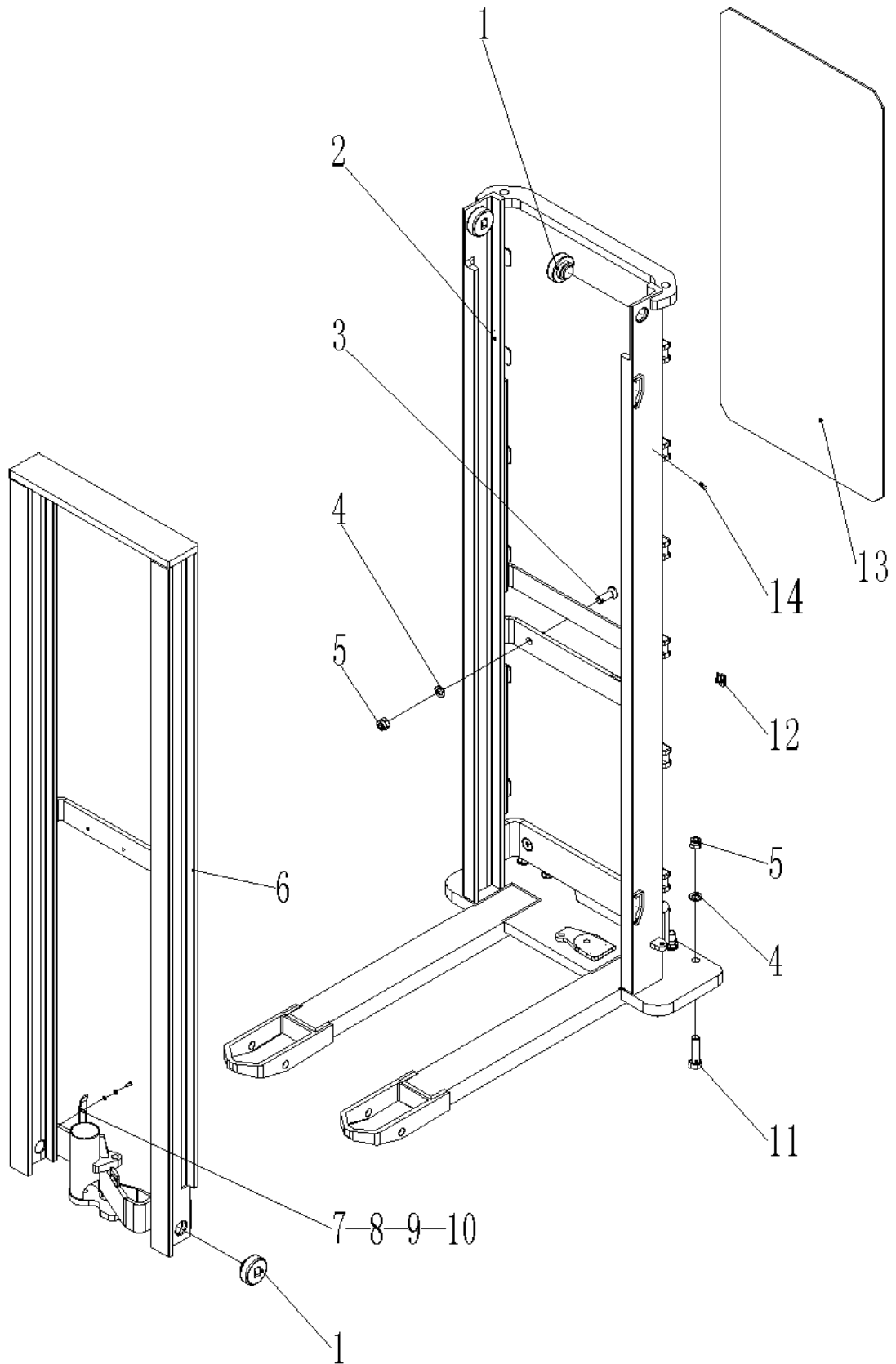

**Fig. 9 Mast Assembly(PS E12D Two-stage mast Lift)**

No.	Art No.	Description	Qty.	Note	Standard
1	9000007753	Compound roller	4		
2	9000008122	Welded inner mast	1	2900	
	9000009137			2600	
3	9000008121	Welded outer mast	1	2900;570×1150	
	9000009136			2600;570×1150	
	9000009141			2900;685×1150	
	9000009143			2600; 685×1150	
4	0090000486	Screw	4	M16×80	GB/T70.1=ISO4762
5	0000025029	Washer	8	16	GB/T95
6	0000024011	Lock nut	8	M16	GB/T889.1=ISO7040
7	2210423001	Screw	4	M16×52	
8	9000008123	Protective glass	1	2900	
	9000009138			2600	
9	9000007782	Spring buckle	10		
10	9000008119	Top glass	1		
11	0090000189	Screw	1	M4x8	GB/T70.3
12	9000008112	Limit board 1	1		
13	0000023853	Screw	2	M4x16	GB/T70.1=ISO4762
14	0000025018	Washer	2	4	GB/T93
15	0000025019	Washer	2	4	GB/T95



Fig. 10 Mast assembly(PS E12F Two-stage mast Full-Free-Lift)



**Fig.10 Mast Assembly(PS E12F Two-stage mast Full-Free-Lift)**

No.	Art No.	Description	Qty.	Note	Standard
1	2240611001	Compound roller	4		
2	9000009091	Welded outer mast	1	2900;570×1150	
	9000009096			2900;685×1150	
3	2210423001	Screw	4	M16×52	
4	0000025029	Washer	8	16	GB/T95
5	0000024011	Lock nut	8	M16	GB/T889.1=ISO7040
6	9000009092	Welded inner mast	1	2900	
7	9000008112	Limit board	1		
8	0000023853	Screw	2	M4×16	GB/T70.1=ISO4762
9	0000025009	Washer	2	4	GB/T93
10	0000025019	Washer	2	4	GB/T95
11	0090000486	Screw	4	M16×80	GB/T70.1=ISO4762
12	9000007782	Spring buckle	8	1	
13	9000009093	Protective glass	1	2900	
14	0090000189	Screw	1	M4x8	GB/T70.3



4	9000008376	Aluminium plate	1		
5	1020434002	Wiring terminal	1	BD-M8	
6	9000008586	Fuse seat	1	BD-2×10A	
7	1000434041	Pump contactor	1	DC24V	
8	9000008585	Plug fixing plate	1		
9	9000008409	Controller components	1		
10	1000434006	Traction motor contactor	1	DC24V	
11	9000008598	Main contactor assembly plate	1		
12	1020434003	Copper bar	1		
13	1000434007	Fuse seat	2	SYT	
14	1020434001	Fuse	1	200A	
15	2210434004	Fuse	1	150A	
16	9000008374	Copper bar	1		
17	9000008373	Copper bar	1		
18	0000023516	Screw	3	M5×10	GB/T818=ISO7045
19	0000025015	Washer	1	5	GB/T93-
20	0000025014	Washer	1	5	GB/T95
21	0000025018	Washer	12	4	GB/T93
22	0000025019	Washer	12	4	GB/T95
23	0000023073	Screw	2	M4×10	GB/T818=ISO7045
24	0000023019	Screw	2	M4×30	GB/T818=ISO7045
25	0000023307	Screw	4	M4×10	GB/T818=ISO7045
26	0000023211	Screw	4	M4×16	GB/T818=ISO7045
27	0000025010	Washer	9	6	GB/T93
28	0000023055	Washer	9	6	GB/T95
29	0000023478	Screw	5	M6×12	GB/T70.1=ISO4762
30	0000023923	Screw	4	M6×18	GB/T70.1=ISO4762
31	0000025001	Washer	11	8	GB/T93
32	0000025011	Washer	11	8	GB/T95
33	0000024086	Nut	11	M8	GB/T6170
34	0000023067	Screw	4	M8×16	GB/T70.1=ISO4762
35	9000008372	Copper bar	1		
36	0000023727	Screw	2	M4×6	GB/T818=ISO7045

Fig. 12 Main harness(manual steering)

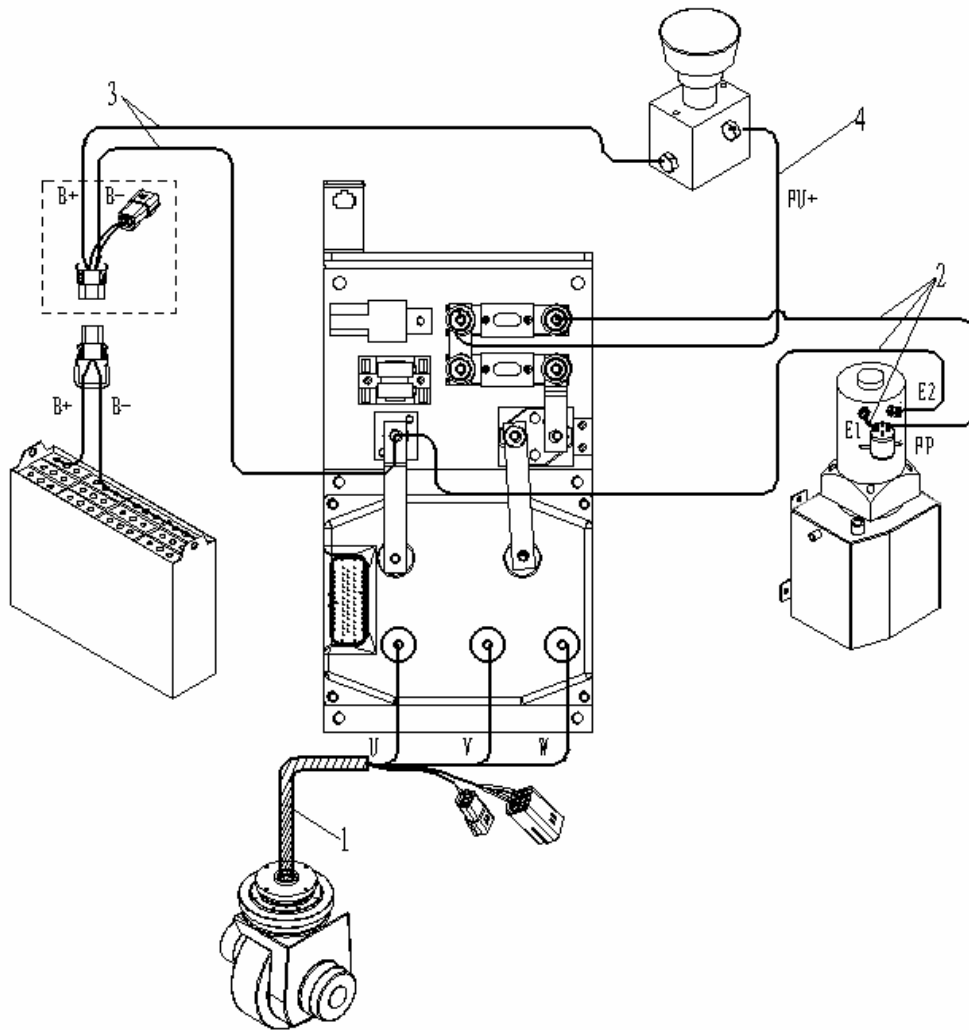
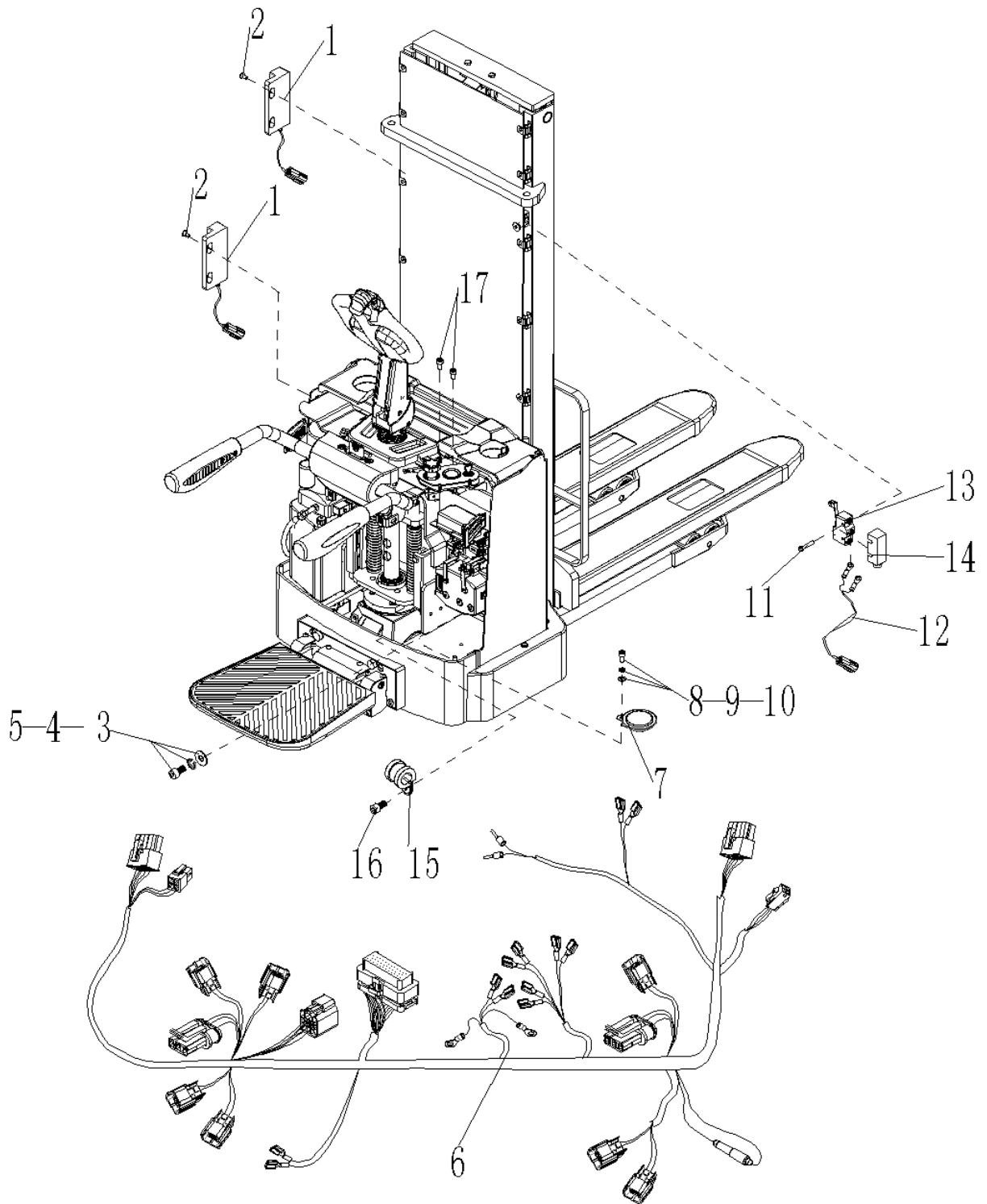

Fig. 12 Main Harness(manual steering)

No.	Art No.	Description	Qty.	Note	Standard
1	9000008405	Drive motor cable	1		
2	9000008406	Pump motor cable	1		
3	9000008407	Power supply cable	1		
4	9000008408	FU+ cable	1		

Fig. 13 Electric parts(manual steering)



**Fig.13 Electric parts(manual steering)**

No.	Art No.	Description	Qty.	Note	Standard
1	9000008332	Magnet switch	2	HWK23	
2	0000023083	Screw	4	M3×8	GB/T70.2=ISO7380
3	0000023044	Screw	4	M8×20	GB/T70.1=ISO4762
4	0000025001	Washer	4	8	GB/T93
5	0000025011	Washer	4	8	GB/T97.1
6	9000008403	Main control wiring diagram	1		
7	1000434015	Horn	1	DC24V	
8	0000023478	Screw	1	M6×12	GB/T70.1=ISO4762
9	0000025010	Washer	1	6	GB/T93
10	0000023055	Washer	1	6	GB/T97.1
11	0000023033	Screw	2	M4×25	GB/T70.1=ISO4762
12	9000008404	Limit control wiring harness	1		
13	2040634001	Micro switch	1	XZ-15GW22-B	
14	2040603002	Micro switch cover	1		
15	9000009545	YGE hose clamp	1	26X20	
16	0000023042	Screw	1	M6×10	GB/T70.1=ISO4762
17	0000023106	Screw	2	M6×30	GB/T70.1=ISO4762

Fig. 14 Power supply assembly

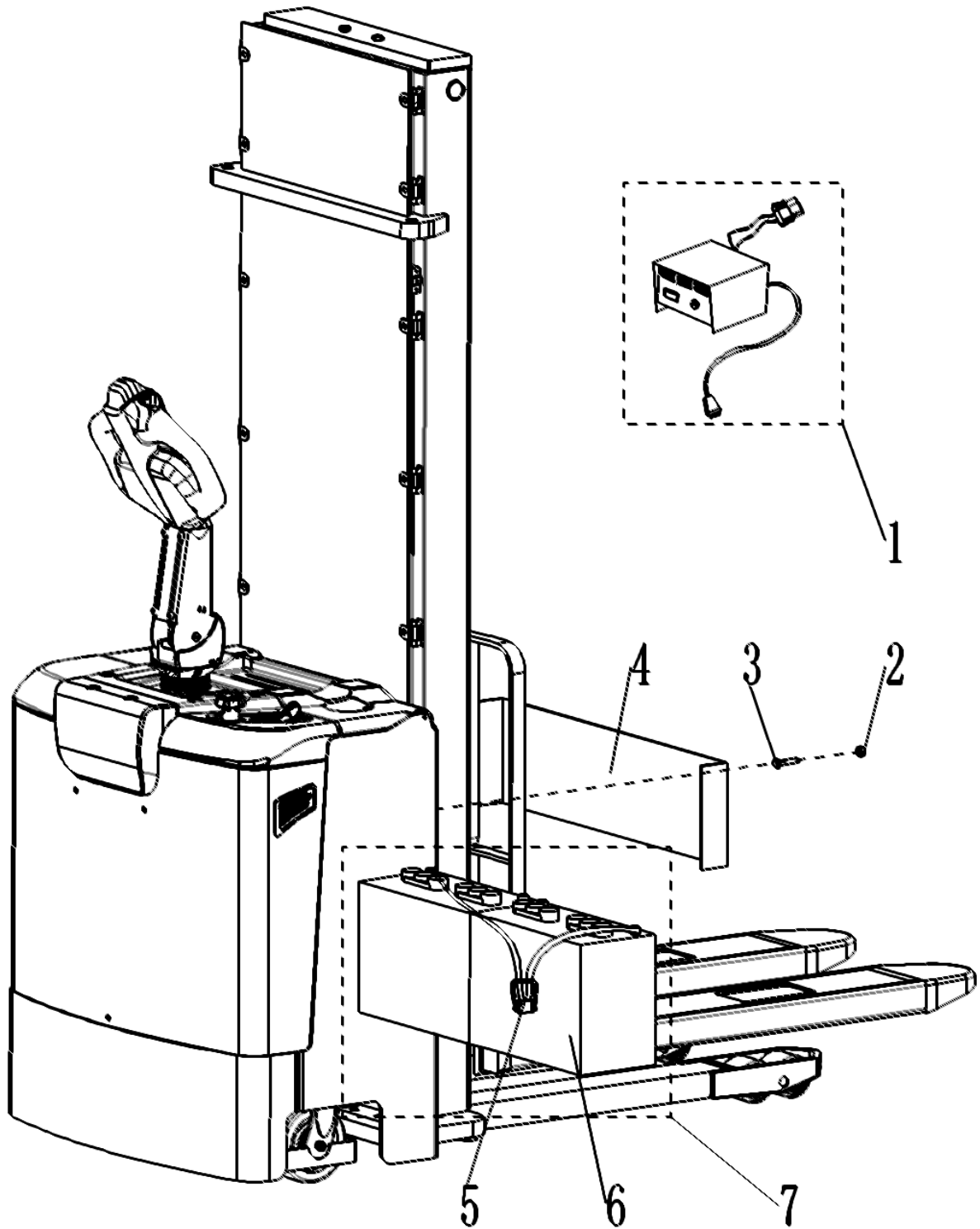



**Fig. 14 Power supply assembly**

No.	Art No.	Description	Qty.	Note	
1	9000010210	Charger	1	Asia in Chinese	
	9000010211			Asia in English	
	9000010212			For EU	
	9000010213			For AUS	
	9000010214			For UK	
	9000010215			For USA	
2	0000024018	Nut	2	M10	GB/T6170
3	0000023355	Bolt	2	M10x45	GB/T5783
4	9000009960	Battery fixing plate	1		
5	9000009993	Plug components	1		
6	9000009959	Battery components	1		
7	9000009167	Power supply assembly	1	90Ah	

Fig. 15 Hydraulic system(PS E12S One-stage mast)

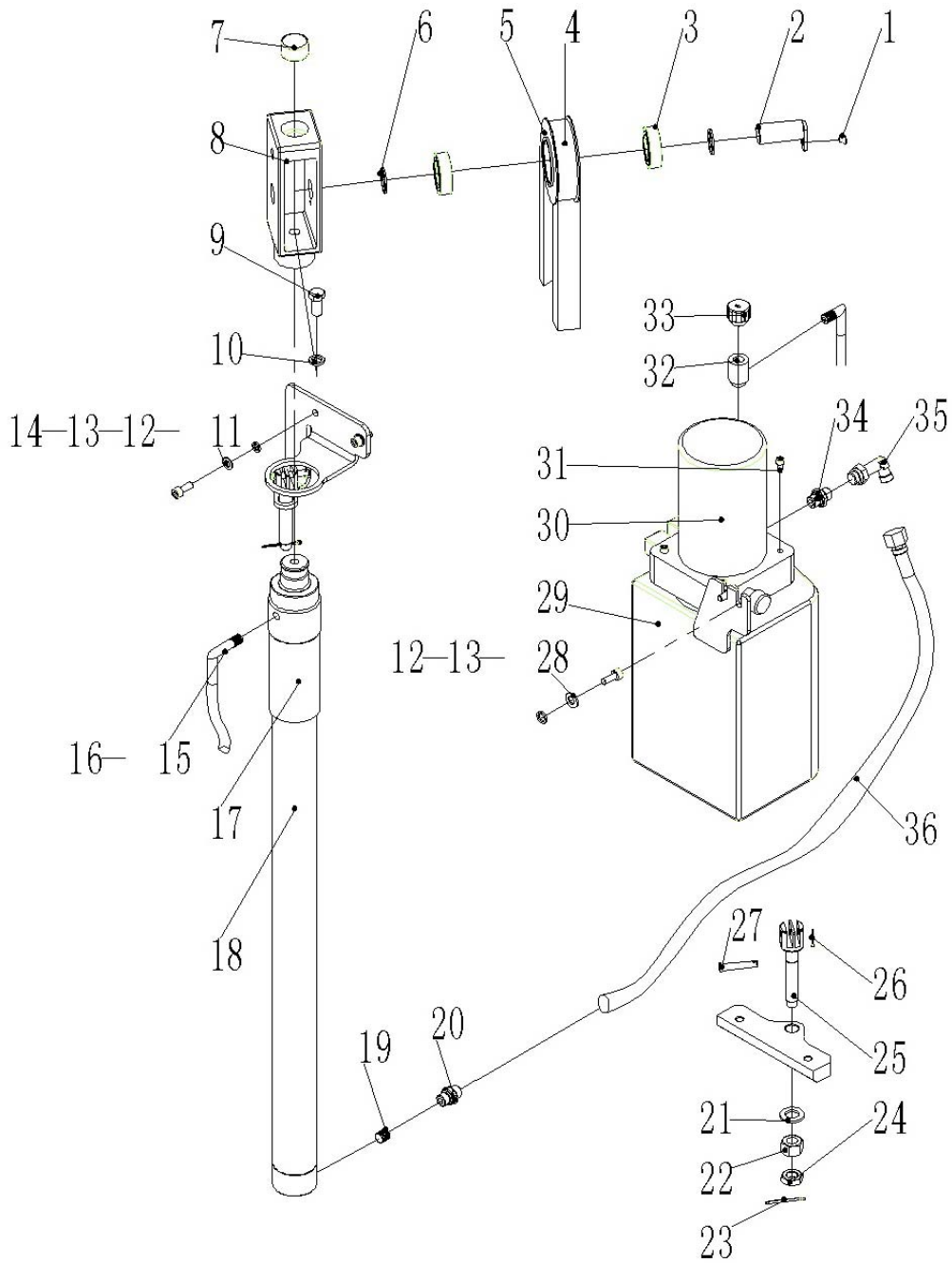
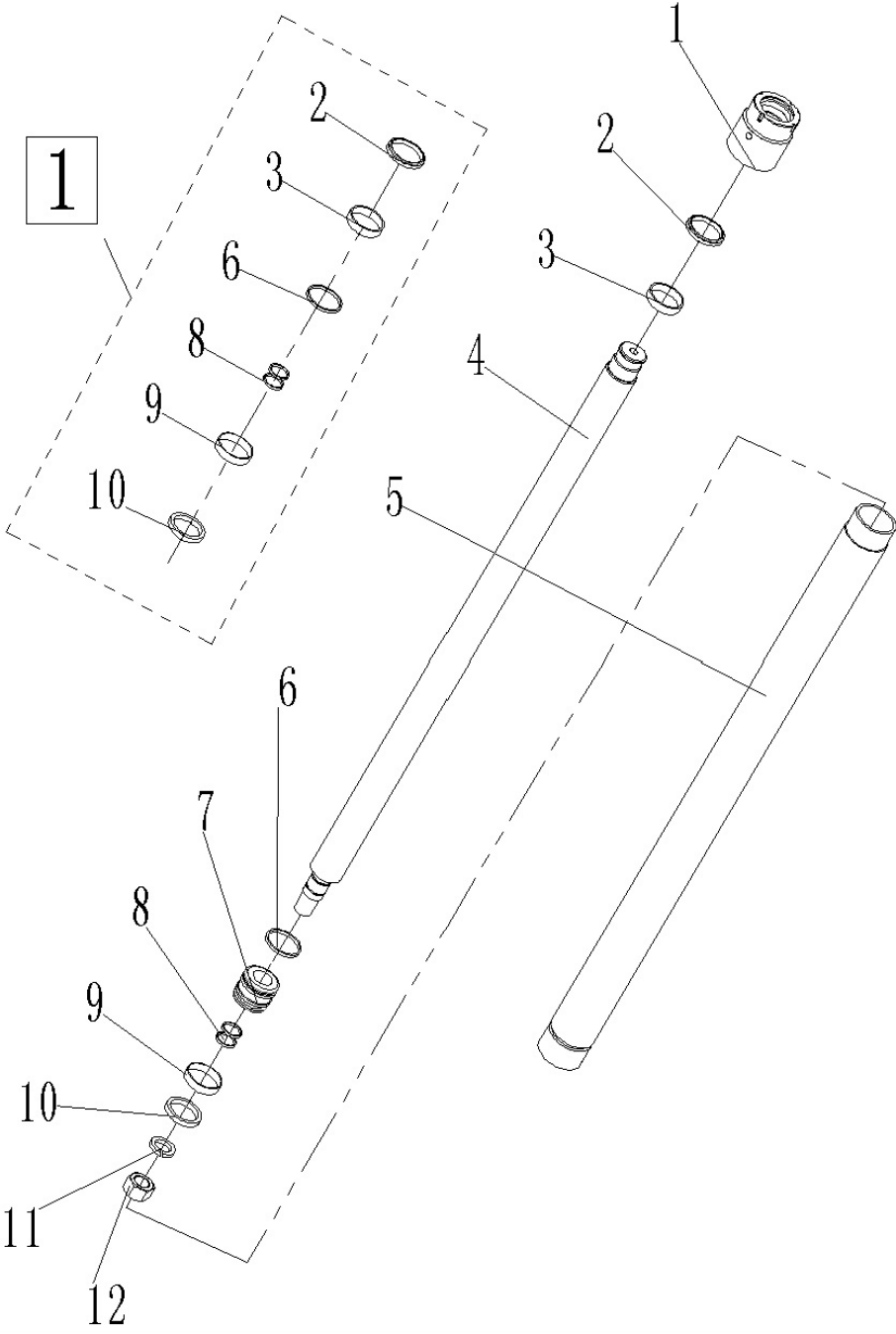

Fig. 15 Hydraulic system(PS E12S One-stage mast)

No.	Art No.	Description	Qty.	Note	Standard
1	0000023138	Screw	1	M6x10	GB/T70.3
2	2300301001	Pin fitting	1		
3	0000027011	Bearing	2	6205	GB/T276=ISO3290
4	0000029004	Chain LH1234	1	63	GB/T6074-2006

5	2000310001	Chain wheel for mast	1		
6	2240302001	Adjusting washer	2		
7	2010319001	Damping pad	1		
8	2310305002	Chain wheel frame	1		
9	0000023226	Bolt	1	M12x25	GB/T5783
10	0000025024	Washer	1	12	GB/T93
11	0000023147	Screw	2	M8x20	GB/T70.1=ISO4762
12	0000025004	Washer	4	8	GB/T93
13	0000025005	Washer	4	8	GB/T95
14	9000009356	Holder 1	1		
15	2010317001	Angle	2		
16	9000008140	Oil return tube	1		
17	2000301001	Pulling rod seat	2		
18	9000009357	Cylinder	1	1600	
19	2000337001	Safety valve components	1		
20	9000007842	Straight joint	1		
21	0000025029	Washer	2	16	GB/T95
22	0000024042	Nut	2	M16x1.5	GB/T6171
23	0000028011	Split pin	2	3x40	GB/T91
24	0000024069	Nut	2	M16x1.5	GB/T6173=ISO8675
25	9000009087	Chain tension bar	2		
26	0000028010	Split pin	2	2x20	GB/T91
27	9000009088	Chain pin shaft	2		
28	0000023146	Screw	2	M8x16	GB/T70.1=ISO4762
29	9000008141	Welded cylinder	1		
30	2000300001	DC power unit	1	24V2.2KW2.2	
31	0000023090	Screw	4	M6x35	GB/T70.1=ISO4762
32	2010317003	Joint	1		
33	2000303001	Cylinder cover	1		
34	9000007832	G straight joint	1		
35	9000007838	Steering connecting joint	1		
36	9000007259	Tube assembly	1		

Fig. 16 Cylinder(PS E12S One-stage mast)



**Fig. 16 Cylinder(PS E12S One-stage mast)**

No.	Art No.	Description	Qty.	Note	Standard
1	9000009358	Cylinder cover	1		
2	2000322001	Dust ring	1	40×48-5/6.5	
3	2000322002	Support ring for shaft	1	40×10-2	
4	9000009360	Lever	1		
5	9000009359	Cylinder barrel	1		
6	0000022013	O seal ring	1	45×3.1	GB1235
7	9000009361	Piston	1		
8	0000022014	O seal ring	2	25×3.1	GB1235
9	2000322003	Support ring for hole	1	45×10-2	
10	2010322001	Y seal ring	1	45×35-6	
11	0000025033	Washer	1	20	GB/T93
12	0000024074	Nut	1	M20×1.5	GB/T6171
□	9000009953	Cylinder seal assembly	1		



**Fig. 17 Pump system**

No.	Art No.	Description	Qty.	Note	Standard
1	2000335001	Pump contactor	1		
2	2000335002	Carbon brush (components)	1	Iskra	
3	2000334001	Motor	1	Iskra	
4	2000323001	Plug	1		
5	2000300002	Valve	1		
6	2000335003	Electromagnetic valve	1		
7	2000335004	Check valve	1		
8	2000323002	Screw	4		
9	2000335005	Flow control valve	1		
10	2000323003	Plug	1		
11	2000335006	Overflow valve	1		
12	2000322004	O ring	1		
13	2000317008	Oil return tube	1		
14	2000317009	Oil return tube	1		
15	2000300003	Gear pump	1		
16	2000317010	Oil suction pipe	1		
17	2000300004	Filter	1		

Fig. 18 Hydraulic system(PS E12D Two-stage mast Lift)

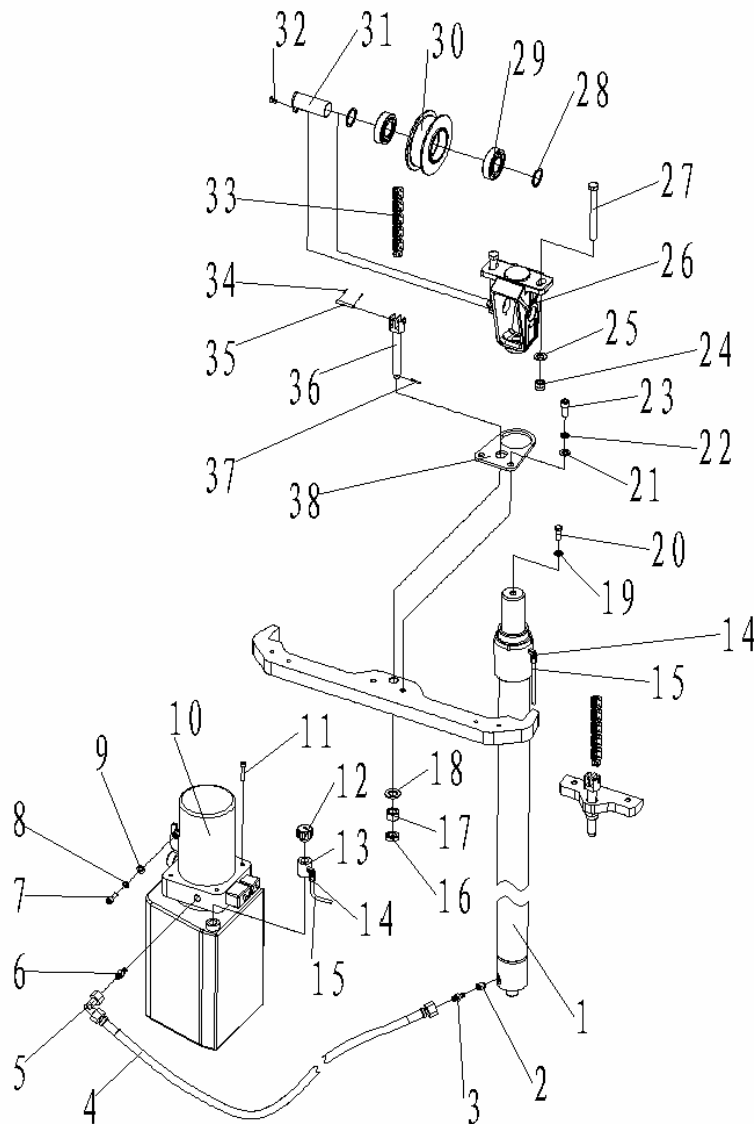

Fig. 18 Hydraulic system(PS E12D Two-stage mast Lift)

No.	Art No.	Description	Qty.	Note	
1	9000008124	Cylinder	1	2900	
	9000009139		1	2600	
2	2000337001	Safety valve components	1		
3	9000007842	Straight joint	1		
4	9000007259	Tube	1		
5	9000007838	Steering connecting joint	1		
6	9000007832	G straight joint	1		
7	0000023067	Screw	2	M8x16	GB/T70.1=ISO4762



8	0000025001	Washer	2	8	GB/T93
9	0000025011	Washer	2	8	GB/T95
10	2000300001	DC power unit	1	24V2.2KW2.2	
11	0000023090	Screw	4	M6×35	GB/T70.1=ISO4762
12	2000303001	Vent plug	1		
13	2010317003	Joint	1		
14	2010317001	Angle	2		
15	9000008140	Oil return tube	1		
16	0000024014	Nut	2	M16×1.5	GB/T6173 =ISO8675
17	0090000442	Nut	2	M16×1.5	GB/T6171
18	0000025029	Washer	2	16	GB/T95
19	0000025024	Washer	1	12	GB/T93
20	0000023094	Screw	1	M12×30	GB/T70.1=ISO4762
21	0090000047	Washer	2	10	GB/T97.1
22	0000023006	Washer	2	10	GB/T93
23	0000023088	Screw	2	M10×25	GB/T70.1=ISO4762
24	0000024006	Nut	2	M12	GB/T889.1=ISO7040
25	0000025032	Washer	2	12	GB/T95
26	2220305001	Chain wheel frame	1		
27	0000023209	Bolt	2	M12×130	GB/T5780
28	9000008118	Adjusting washer	2		
29	0000027012	Bearing	2	6206	GB/T276=ISO3290
30	9000008117	Chain wheel	1		
31	9000008116	Chain wheel axle components	1		
32	0000023091	Screw	1	M6×12	GB/T70.3
33	0000029035	Chain	1	2900	GB/T6074
	0090000490	Chain	1	2600	GB/T6074
34	0000028111	Split pin	4	1.6×10	GB/T91
35	0000028110	Pin roll	2	6×40	GB/T880
36	9000008114	Chain pulling bar	2		
37	0000028011	Split pin	2	3×40	GB/T91
38	9000008113	Fixing plate	1		

Fig. 19 Cylinder(PS E12D Two-stage mast Lift)

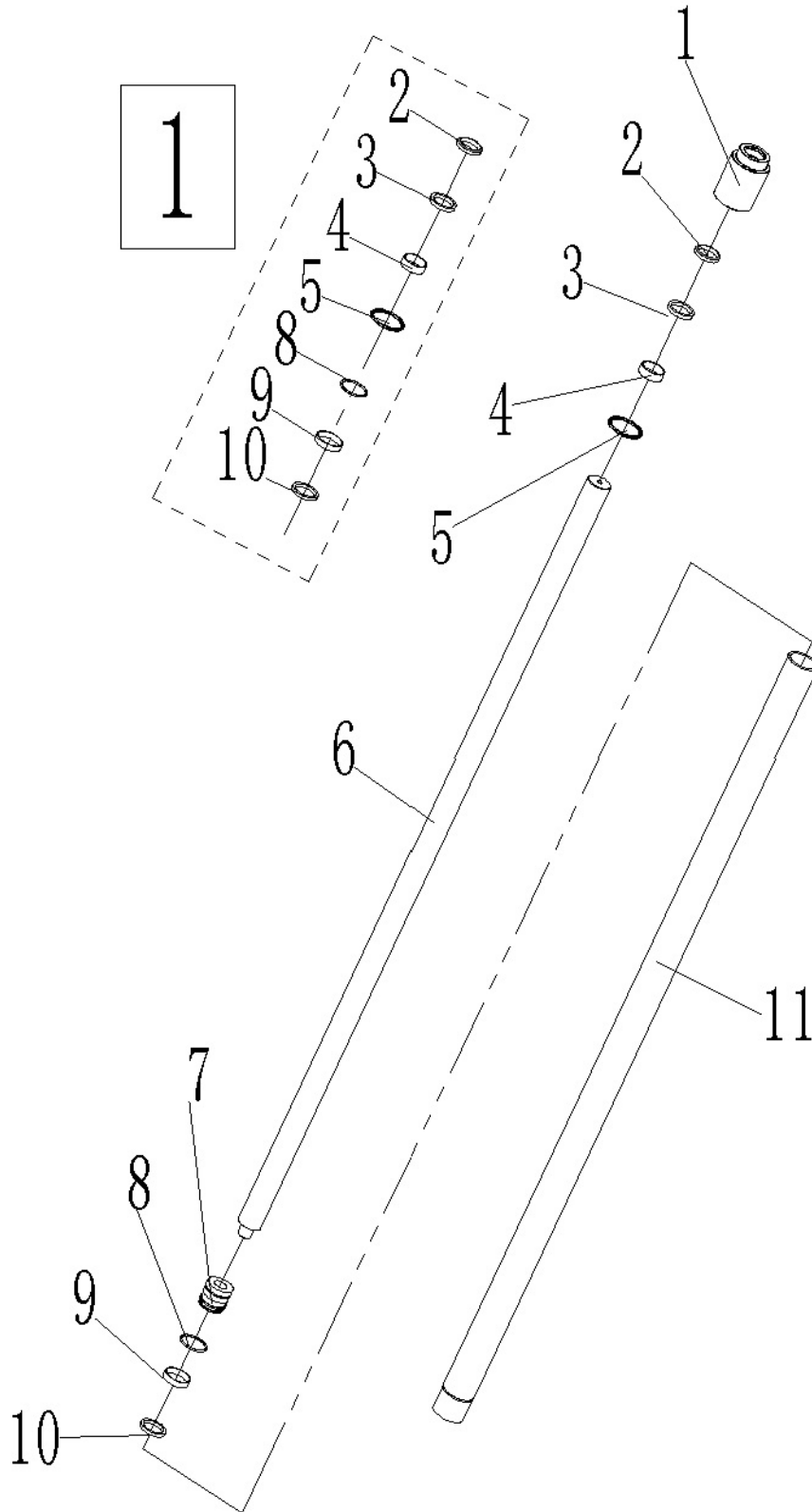

**Fig. 19 Cylinder(PS E12D Two-stage mast Lift)**

No.	Art No.	Description	Qty.	Note	Standard
1	9000009168	End cap	1		
2	9000009169	Dust ring	1	40×48×5/6.5	
3	9000009170	Y ring for shaft	1	40×50×6/7	
4	9000009171	Support ring for shaft	1	40×44×10	
5	0090000491	O ring	1	56X2.4	GB12
6	9000009173	Piston rod	1	2900	
	9000009175			2600	
7	9000009176	Piston	1		
8	0000022029	O ring	1	Φ50×3.1	GB1235
9	9000009177	Support ring for hole	1	46×50×10	
10	9000009178	Y ring for hole	1	40×50×6/7	
11	9000009188	Cylinder body	1	2900	
	9000009190			2600	
□	9000009954	Cylinder seal kit	1		

Fig. 20 Hydraulic system(PS E12F Two-stage mast Full-Free-Lift)

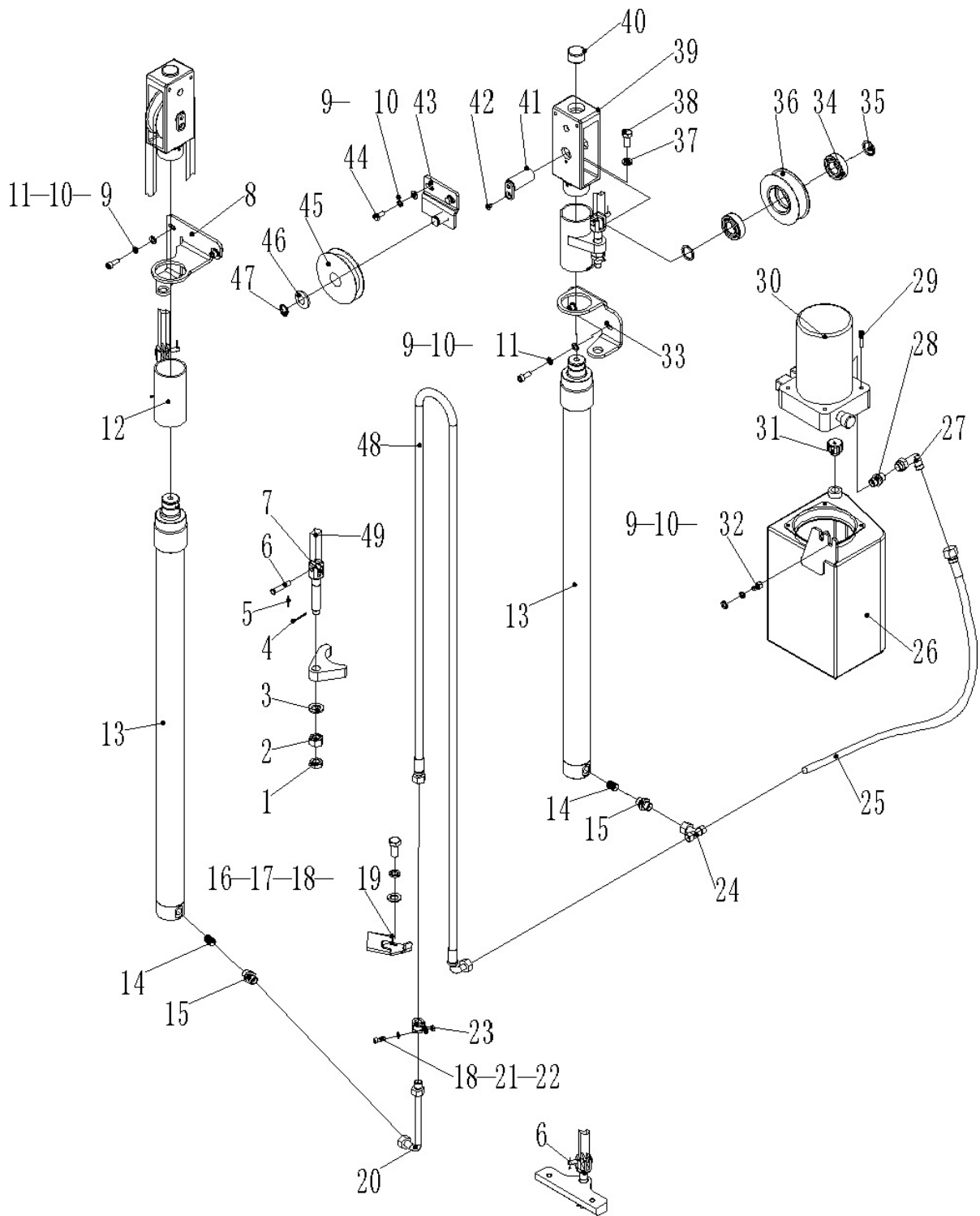

**Fig. 20 Hydraulic System(PS E12F Two-stage mast Full-Free-Lift)**

No.	Art No.	Description	Qty.	Note	Standard
1	0000024010	Nut	4	M16	GB/T6172.1
2	0000024184	Nut	4	M16	GB/T6170
3	0000025029	Washer	4	16	GB/T95
4	0000028011	Split pin	4	3×40	GB/T91
5	0000028010	Split pin	4	2×20	GB/T91
6	9000009088	Pin roll for chain	4		
7	9000009087	Chain pulling rod	4		
8	9000009003	Cylinder fixing plate	1		
9	0000025005	Washer	4	8	GB/T95
10	0000025004	Washer	4	8	GB/T93
11	0000023146	Screw	4	M8V16	GB/T70.1=ISO4762
12	2000301001	Pulling rod block	2		
13	9000009094	Cylinder	2	2900	
14	2000337001	Safety valve components	2		
15	9000007842	Straight joint	2		
16	2000302005	Tube board	1		
17	0000023845	Screw	2	M6×10	GB/T70.1=ISO4762
18	0000025006	Washer	1	6	GB/T93
19	0000025007	Washer	2	6	GB/T95
20	9000009004	Steel pipe	1		
21	0000023040	Screw	1	M6×16	GB/T70.1=ISO4762
22	0000024061	Nut	1	M6	GB/T6172.1
23	9000008325	YGE hose clamp	1		
24	9000008887	Steering connecting joint	1		
25	9000007259	Tube	1		
26	9000008141	Welded cylinder	1		
27	9000007838	Steering connecting joint	1		
28	9000007832	G straight joint	1		
29	0000023090	Screw	4	M6×35	GB/T70.1=ISO4762
30	2000300001	DC power unit	1		
31	2000303001	Vent plug	1		

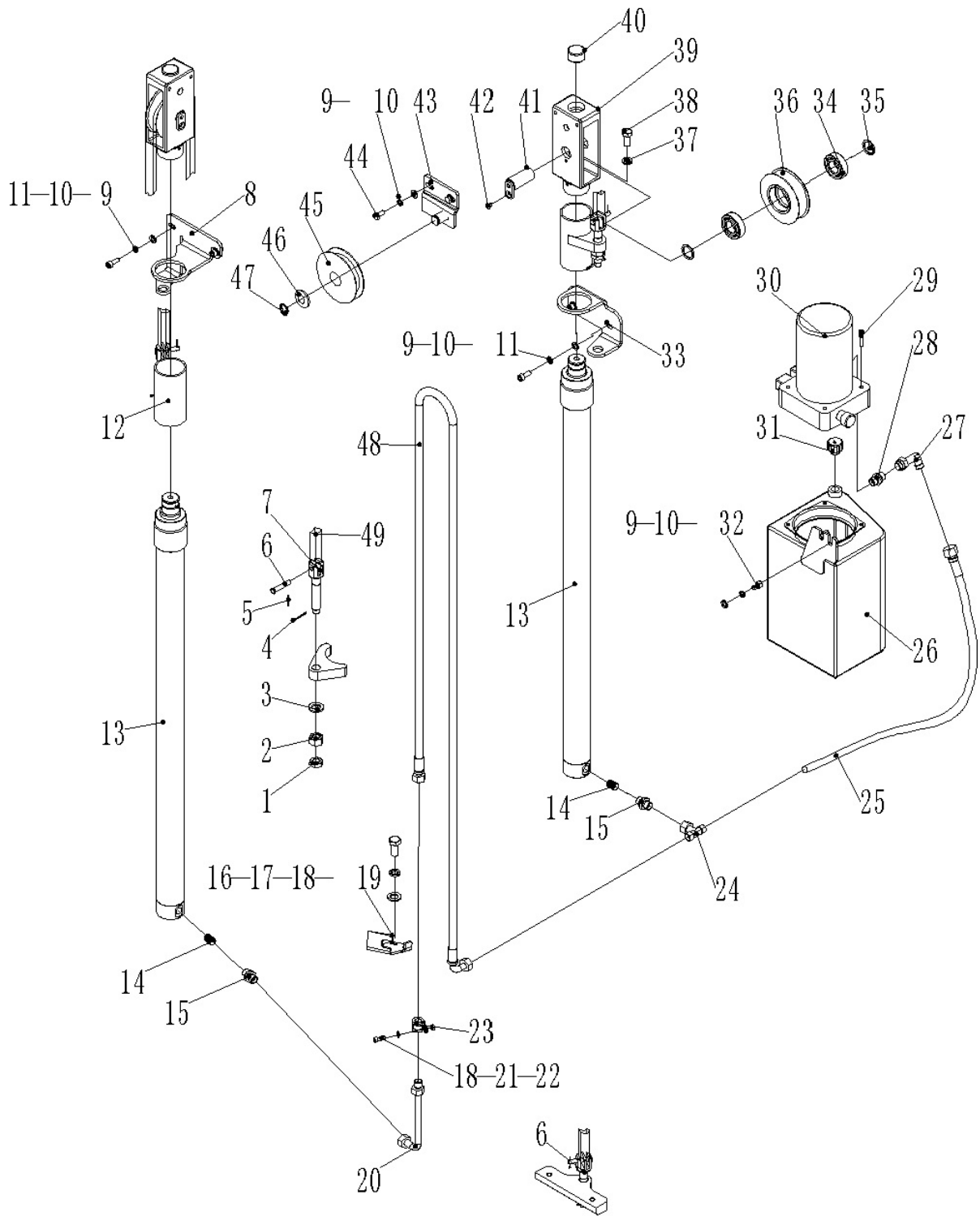

**Fig. 20 Hydraulic System(PS E12F Two-stage mast Full-Free-Lift)**

32	0000023089	Screw	2	M8×12	GB/T70.1=ISO4762
33	9000009003	Frame 1	1		
34	0000027011	Bearing	4	6025	GB/T276=ISO3290
35	2240302001	Adjusting washer	4		
36	2000310001	Chain wheel	2		
37	0000025024	Washer	2	12	GB/T93
38	0000023226	Bolt	2	M12×25	GB/T5783
39	2310305002	Chain frame	2		
40	2010319001	Damping pad	2		
41	2300301001	Pin fitting	2		
42	0000023557	Screw	2	M6×10	GB/T70.3
43	2000301002	Welded pulley frame	1		
44	0000023230	Bolt	2	M8×16	GB/T5783
45	2000310002	Pulley	1		
46	0000025092	Washer	1	20	GB/T97.2
47	0000026003	Circlip	1	20	GB/T894.1
48	9000008888	Tube	1	2900	
49	0000029004	Chain LH1234	2	2900	
					GB/T6074
					GB/T6074

Fig. 21 Cylinder(PS E12F Two-stage mast Full-Free-Lift)

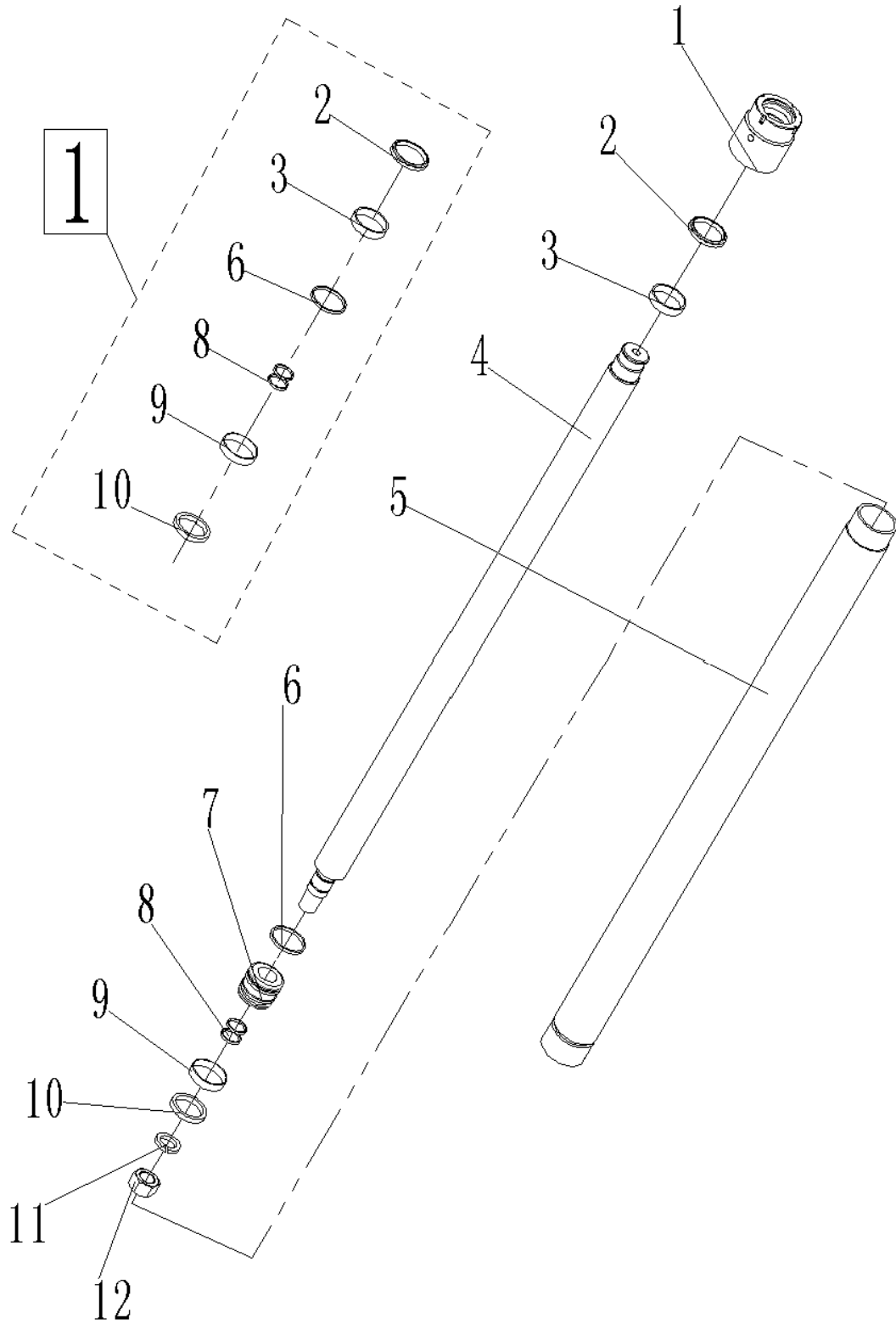



**Fig. 21 Cylinder(PS E12F Two-stage mast Full-Free-Lift)**

No.	Art No.	Description	Qty.	Note	Standard
1	9000009191	Cylinder cap	1		
2	2000322001	Dust ring	1	40×48-5/6.5	
3	2000322002	Support ring for shaft	1	40×10-2	
4	9000009192	Lever	1		
5	9000009193	Cylinder barrel	1		
6	0000022013	O seal ring	1	45×3.1	GB1235
7	9000009194	Piston	1		
8	0000022014	O seal ring	2	25×3.1	GB1235
9	2000322003	Support ring for hole	1	45×10-2	
10	2010322001	Y seal ring	1	45×35-6	
11	0000025033	Washer	1	20	GB/T93
12	0000024074	Nut	1	M20×1.5	GB/T6171
☐	9000009955	Cylinder seal kit	1		

Fig. 22 Drive system(manual steering)

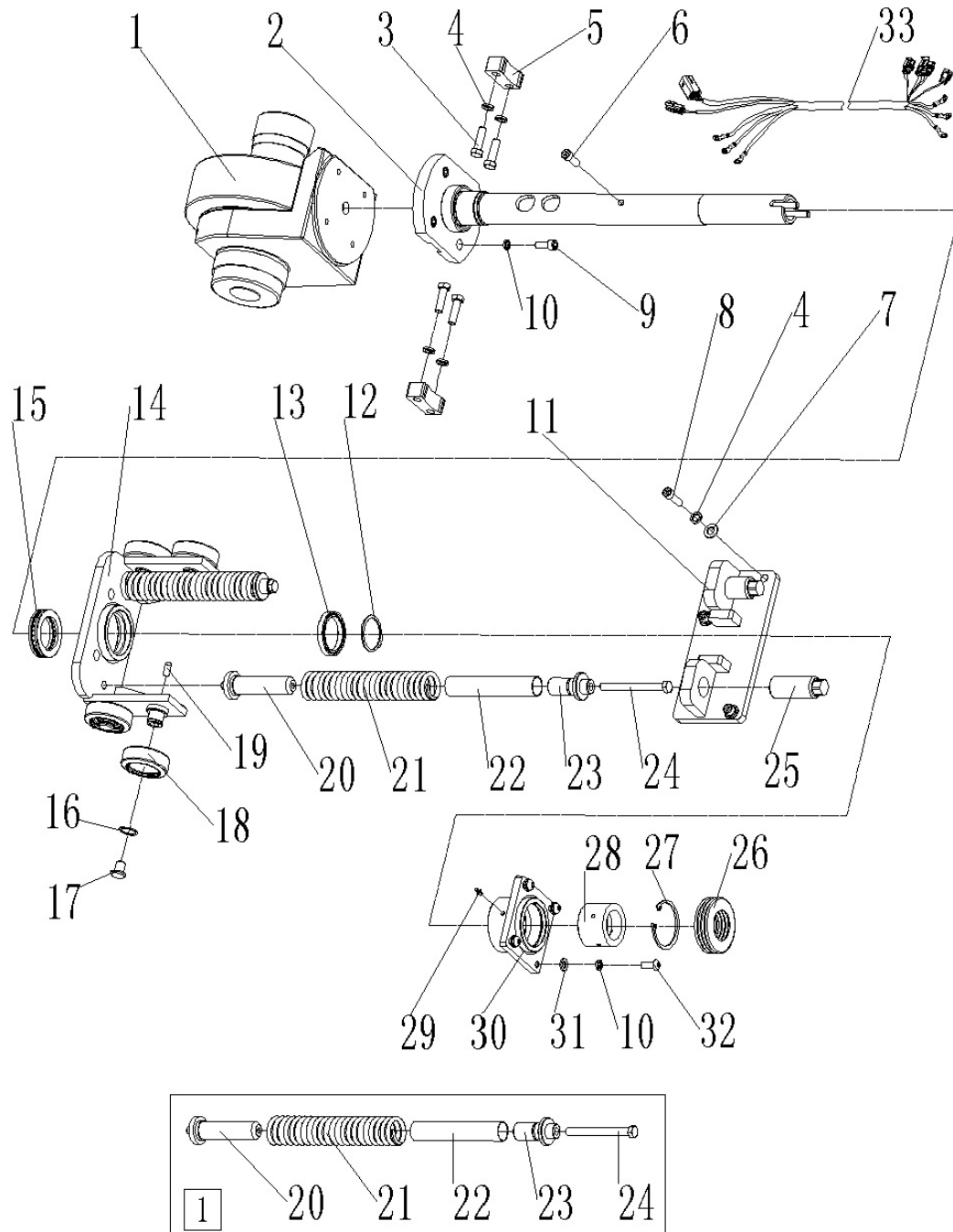
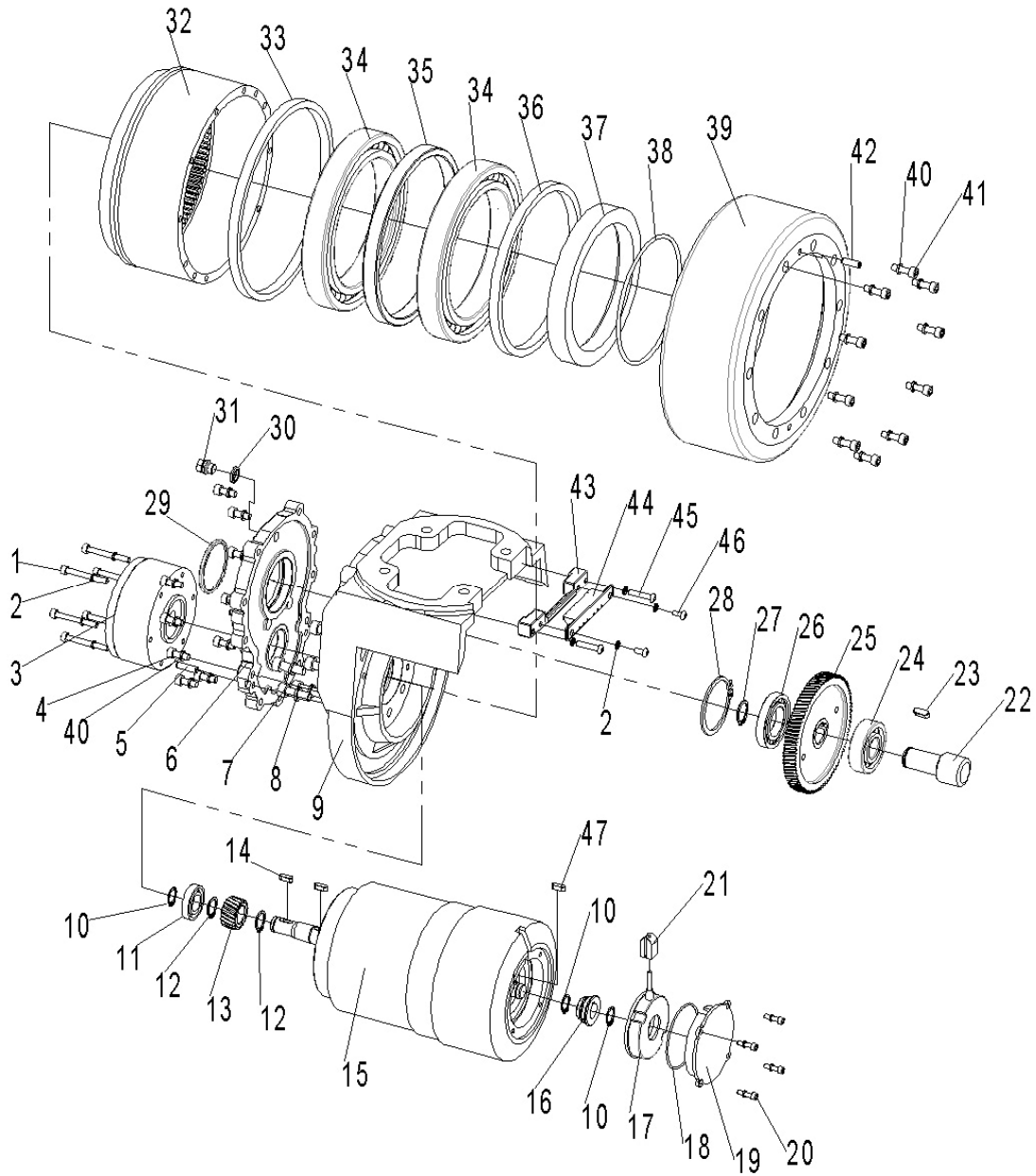

Fig.22 Drive system(manual steering)

No.	Art No.	Description	Qty.	Note	Standard
1	9000007773	Drive wheel	1	∅252	
2	9000008142	Welded long axle	1		

3	0000023184	Bolt	4	M12×40	GB/T5783
4	0000025024	Washer	8	12	GB/T93
5	9000008134	Limit block	2		
6	0000023158	Bolt	1	M10×30	GB/T70.1=ISO4762
7	0000025032	Washer	4	12	GB/T95
8	0000023082	Bolt	4	M12×35	GB/T70.1=ISO4762
9	0000023088	Bolt	4	M10×25	GB/T70.1=ISO4762
10	0000023006	Washer	8	10	GB/T93
11	9000008145	Welded fixing frame	1		
12	0000026015	Circlip	1	∅55	GB/T894.1
13	0090000456	Bearing	1	61811-Z	GB/T276=ISO3290
14	9000008149	Welded wheel frame	1		
15	0000027085	Bearing	1	51111	GB/T301
16	0000026013	Circlip	4	∅25	GB/T894.1
17	9000008152	Adjusting block	4		
18	9000008153	Roller	4		
19	0090000457	Screw	4	M12×20	GB/T77
20	9000008147	Spring guide	2		
21	2000231002	Spring	2	∅7×∅40×	
22	2000208001	Spring guide bushing	2		
23	9000008148	Spring pressing cover	2		
24	2000223001	Bolt	2	M10×180	
25	9000008144	Adjusting stud	2		
26	9000008143	Dust cover	1		
27	0000026020	Circlip	1	∅70	GB/T893.1
28	9000008151	Nylon guide sleeve	1		
29	0000030002	Oil cup	1	M6	JB/T7940.1
30	9000008150	Welded guide sleeve	1		
31	0000025002	Washer	4	10	GB/T95
32	0000023038	Bolt	4	M10×25	GB/T5783
33	9000008405	Drive motor wiring harness	1		
①	9000008146	Spring components	2		

Fig. 23 Drive wheel(43EL)



**Fig.23 Drive wheel(43EL)**

No.	Art No.	Description	Qty.	Note	Standard
1	0090000101	Screw	6	M5×45	GB/T70.1=ISO4762
2	0000025012	Washer	10	5	GB/T93
3	9000008846	Brake	1		
4	0000023040	Screw	11	M6×16	GB/T70.1=ISO4762
5	0000028175	Dowel pin	2	6×22	GB/T120.2
6	9000008847	Gear box cover	1		
7	0000023047	Screw	5	M8×25	GB/T70.1=ISO4762
8	0000025012	Washer	5	8	GB/T93
9	9000008848	Gear box	1		
10	0000026004	Circlip	3	15	GB894.1
11	0000022232	Oil seal	1	17×35×7	GB/T9877
12	0000026005	Retaining ring	2	17	GB/T894.1
13	9000008849	Small gear	1		
14	0000036002	Flat key	2	A5×14	GB/T1096
15	9000008850	AC motor	1		
16	9000008851	Shaft sleeve	1		
17	9000008852	Sensor	1		
18	0000022002	O seal ring	1	6.3×1.8	GB/T3452.1
19	9000008853	Protective cover	1		
20	0090000473	Screw	4	M4×10	GB/T70.3
21	9000008854	Bushing	1		
22	9000008855	Gear shaft	1		
23	0000036001	Flat key	1	A6×16	GB/T1096
24	0000027067	Bearing	1	6304	GB/T276=ISO3290
25	9000008856	Big gear	1		
26	0090000285	Bearing	1	6006	GB/T276=ISO3290
27	0000026003	Circlip	1	20	GB/T894.1
28	0000026007	Circlip	1	55	GB/T893.1

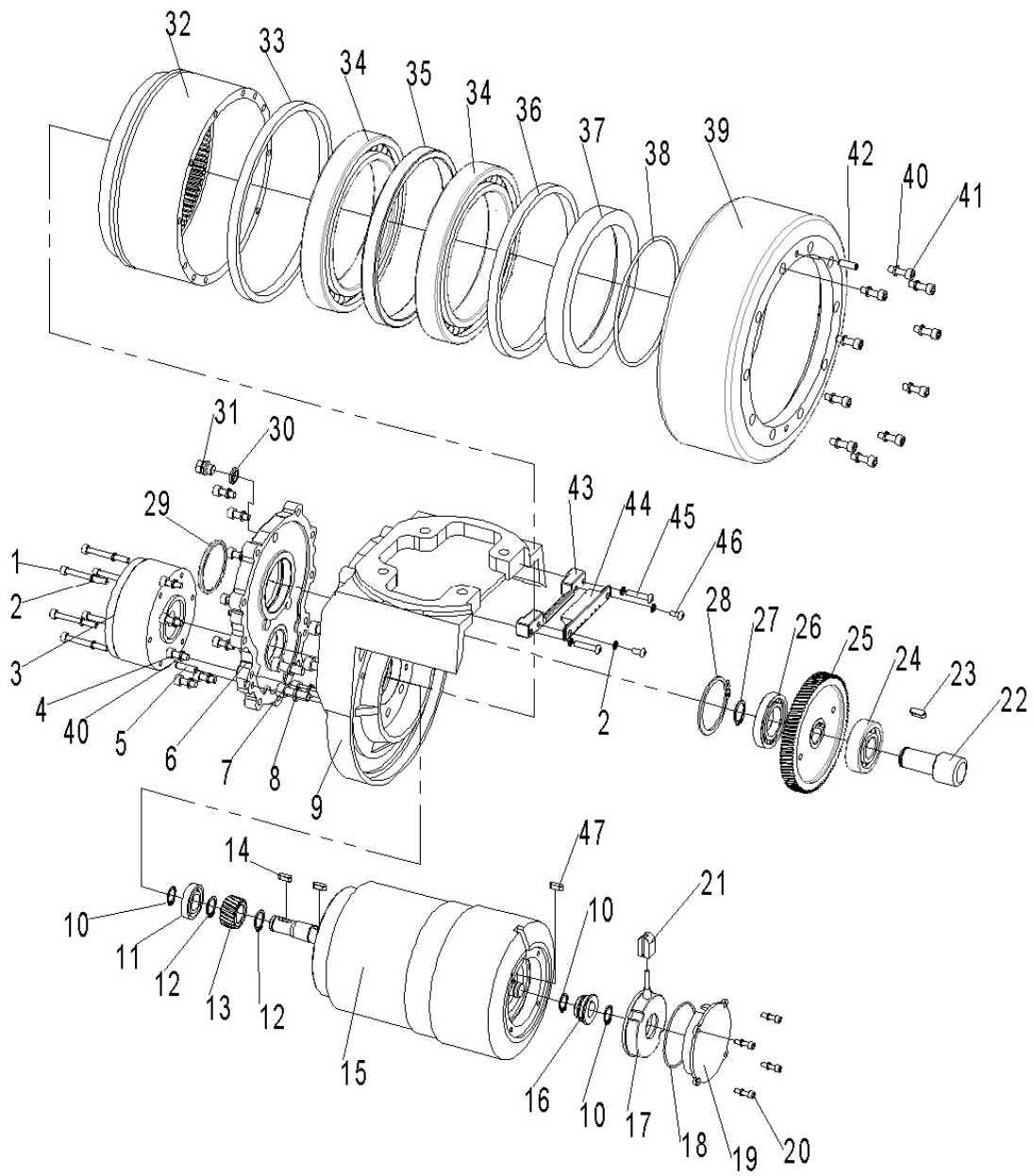

**Fig.23 Drive wheel(43EL)**

29	9000008857	Cover	1		
30	0000025021	Washer	1	10	JB/T982
31	2000303001	Vent plug	1	10	
32	9000008858	Internal gear	1		
33	0000022007	Oil seal	1	188×202×10	GB/T9877
34	0090000453	Bearing	2	61926-2LS	GB/T276=ISO3290
35	9000008859	Bushing	1		
36	0090000178	Oil seal	1	160×175×10	GB/T9877
37	9000008860	Oil seal seat	1		
38	0090000454	O ring	1	125×3.55	GB/T3452.1
39	9000008861	Drive wheel	1		
40	0000025006	Washer	21	6	GB/T93
41	0000023062	Screw	10	M6×20	GB/T70.1=ISO4762
42	0000028177	Dowel pin	2	6×20	GB/T119.1
43	9000008862	Down wire holder	1		
44	9000008863	Upper wire holder	1		
45	0000023065	Screw	2	M5×25	GB/T70.2=ISO7380
46	0090000041	Screw	2	M5×10	GB/T70.2=ISO7380
47	0090000475	Flat key	1	A 5×10	GB/T1096

Fig. 24 Instrument components

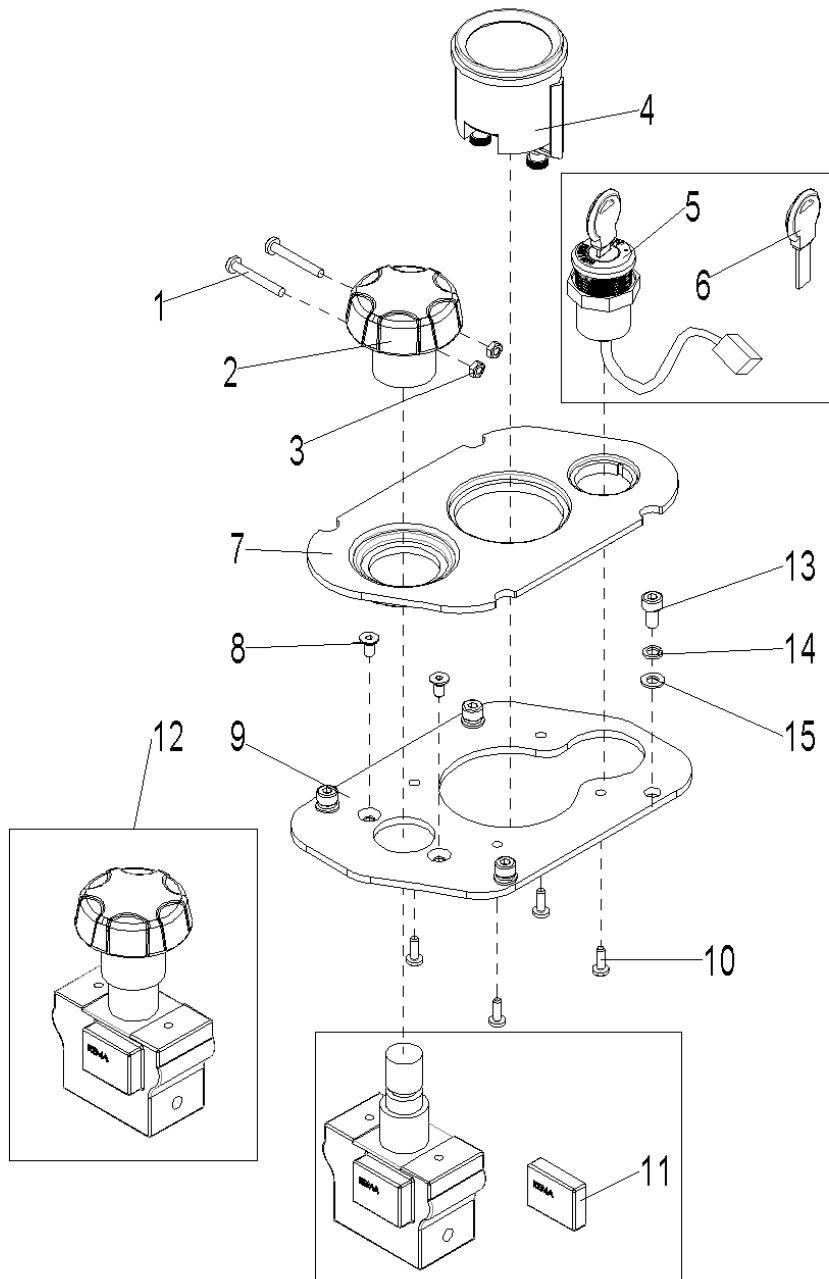
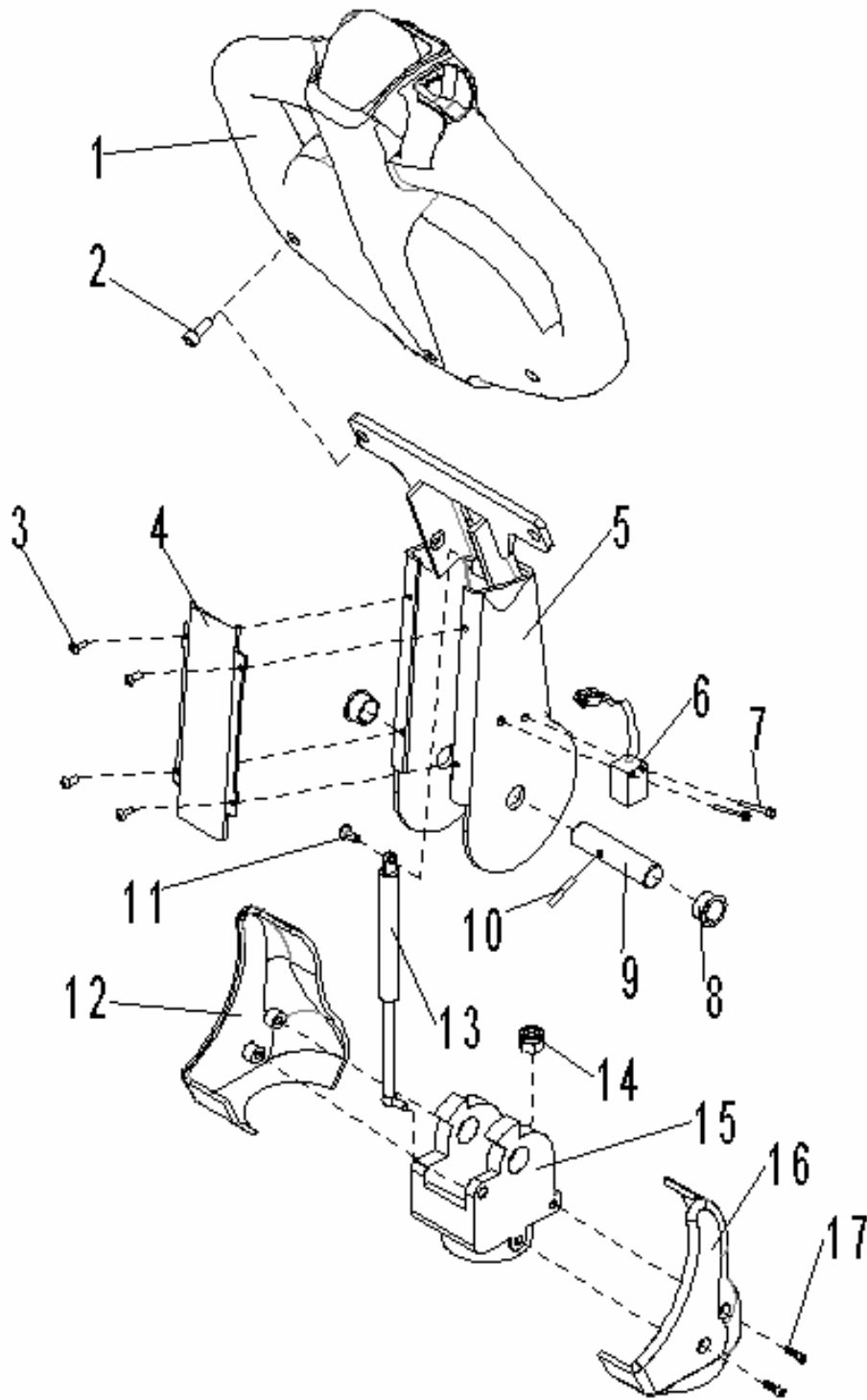



**Fig.24 Instrument Components**

No.	Art No.	Description	Qty.	Note	Standard
1	0000023685	Screw	2	M3×25	GB/T818=ISO7045
2	9000008516	Emergency button head	1		
3	0000024002	Nut	2	M3	GB/T6170
4	1000434025	Indicator	1	CURTIS 803	
5	9000008326	Key switch	1	LKS-101A	
6	9000008519	Key	1		
7	9000007938	Plastic plate	1		
8	0000023215	Screw	2	M5×10	GB/T70.3
9	9000007939	Fixing plate	1		
10	0090000272	Screw	4	M4×12	GB/T6560
11	9000008517	Micro switch	1		
12	9000008515	DC power switch	1	ZDK32-350	
13	0000023053	Screw	3	M6X12	GB/T70.1=ISO4762
14	0000025010	Washer	3	6	GB/T93
15	0000023055	Washer	3	6	GB/T95

Fig. 25 Tiller arm assembly



**Fig.25 Tiller arm assembly**

No.	Art No.	Description	Qty.	Note	Standard
1	1100100001	Canbus control tiller	1	C 94300-90	
2	0000023232	Bolt	2	M8×25	GB/T5783
3	1000123003	Screw	4	M4×8	GB/T70.2=ISO7380
4	9000009961	Long cover board	1		
5	9000009962	Welded long tiller arm	1		
6	9000008327	Proximity switch	1	NBN5-F7-E2	
7	0000023075	Screw	2	M3×20	
8	1000113001	Shoulder harness	2	∅17×∅19×11	
9	9000007928	Tiller axle	1		GB/T70.1=ISO4762
10	0000028003	Dowel pin	1	∅4×24	
11	0000023044	Screw	1	M8×20	
12	9000007930	Left tiller cover	1		GB/T879.1
13	1010121001	Air spring	1	400N	
14	0000023005	Lock nut	2	M10	
15	9000007929	Tiller seat	1		
16	9000007931	Right tiller cover	1		GB/T889.1=ISO7040
17	0000023519	Screw	4	M6×10	
					GB/T70.2=ISO7380

Fig. 26 Tiller head

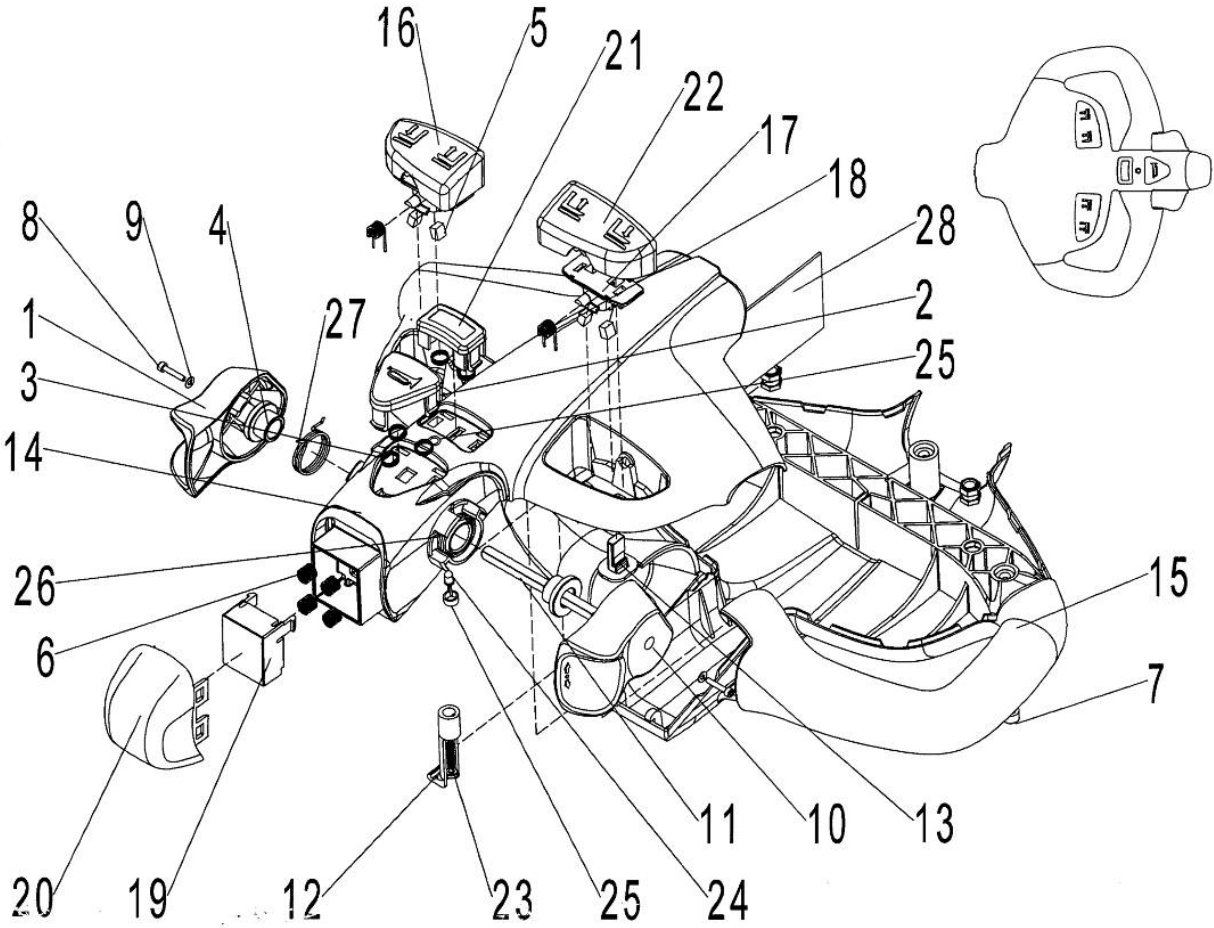

**Fig.26 Tiller head**

No.	Art No.	Description	Qty.	Note	Standard
1	1010114001	Left driving button	1		
2	1000114015	Horn button	1		
3	1000131009	Spring for horn button	5		
4	1000113004	Bushing for camshaft	2		
5	1000137001	Magnet	4		
6	1000131010	Spring for emergency button	4		
7	0000023058	Screw	3	M6×10	GB/T70.1=ISO4762
8	0000023057	Screw	2	M3×16	GB/T70.1=ISO4762
9	0000025017	Washer	2	3	GB/T95
10	1010114003	Right driving button	1		
11	1000107002	Shaft for driving button	1		
12	1000137002	PCB terminal	1		
13	1000134005	Pressure sensor	2		
14	1000103012	Upper part of handle	1		
15	1000103013	Under part of handle	1		
16	1000114017	Left elevator button	1		
17	1000137003	Magnet assembly seat	2		
18	1000131011	Torsional spring	2		
19	1000114018	Spring assembly seat for emergency button	1		
20	1000114020	Emergency button	1		
21	1000114021	Cover for option switch	1		
22	1000114022	Right elevator button	1		
23	0000023060	Screw	1	ST4.2×25	GB/T845
24	1000134006	LED bi-color light	1		
25	1000103014	Assembly seat for LED bi-color light	1		
26	1000131012	Torsional spring for right driving button	1		
27	1000131013	Torsional spring for left driving button	1		
28	1100135001	PCB	1		

## Easy worn parts list

No.	Art No.	Description	Qty.	Fig./Position	Note
1	0000027001	Bearing 6204	4	Fig.6/15	Steering wheel
2	2210416001	Castor	2	Fig.6/17	
3	9000008896	Wheel set	2	Fig.6/19	
4	2000416002	Load roller	4	Fig.7/4	Load wheel
5	0000027001	Bearing 6204	8	Fig.7/5	
6	9000008895	Wheel set	4	Fig.7/7	
7	9000007782	Spring card buckle	10	Fig.8/6	Mast assembly
				Fig.9/9	
				Fig.10/10	
8	1000434040	Fuse 10A	1	Fig.11/3	Electronic control assembly(manual steering)
9	1020434001	Fuse 200A	1	Fig.11/14	
10	2210434004	Fuse 150A	1	Fig.11/15	
11	2000322001	Dust ring	1	Fig.16/2	Cylinder(PS E12S One-stage mast)
12	2000322002	Support ring for shaft	1	Fig.16/3	
13	0000022013	O seal ring	1	Fig.16/6	
14	0000022014	O seal ring	2	Fig.16/8	
15	2000322003	Support ring for hole	1	Fig.16/9	
16	2010322001	Y seal ring	1	Fig.16/10	
17	9000009953	Cylinder seal assembly	1	Fig.16/□	
18	2000335002	Carbon brush (components)	1	Fig.17/2	Pump system
19	9000009169	Dust ring	1	Fig.19/2	Cylinder(PS E12D Two-stage mast Lift)
20	9000009170	Y ring for shaft	1	Fig.19/3	
21	9000009171	Support ring for shaft	1	Fig.19/4	
22	0090000491	O ring	1	Fig.19/5	
23	0000022029	O ring	1	Fig.19/8	
24	9000009177	Support ring for hole	1	Fig.19/9	
25	9000009178	Y ring for hole	1	Fig.19/10	
26	9000009954	Cylinder seal assembly	1	Fig.19/□	
27	2000322001	Dust ring	1	Fig.21/2	Cylinder(PS E12F Two-stage
28	2000322002	Support ring for shaft	1	Fig.21/3	

29	0000022013	O seal ring	1	Fig.21/6	mast Full-Free-Lift)
30	0000022014	O seal ring	2	Fig.21/8	
31	2000322003	Support ring for hole	1	Fig.21/9	
32	2010322001	Y seal ring	1	Fig.21/10	
33	9000009955	Cylinder seal assembly	1	Fig.21/11	
34	0000022002	O seal ring	1	Fig.23/18	Drive wheel(43EL)
35	1010121001	Air spring	1	Fig.25/13	Tiller arm assembly
36	1000113001	Shoulder harness	2	Fig.25/8	

# SPAREPARTS LIST

## Electric Stacker PS B12

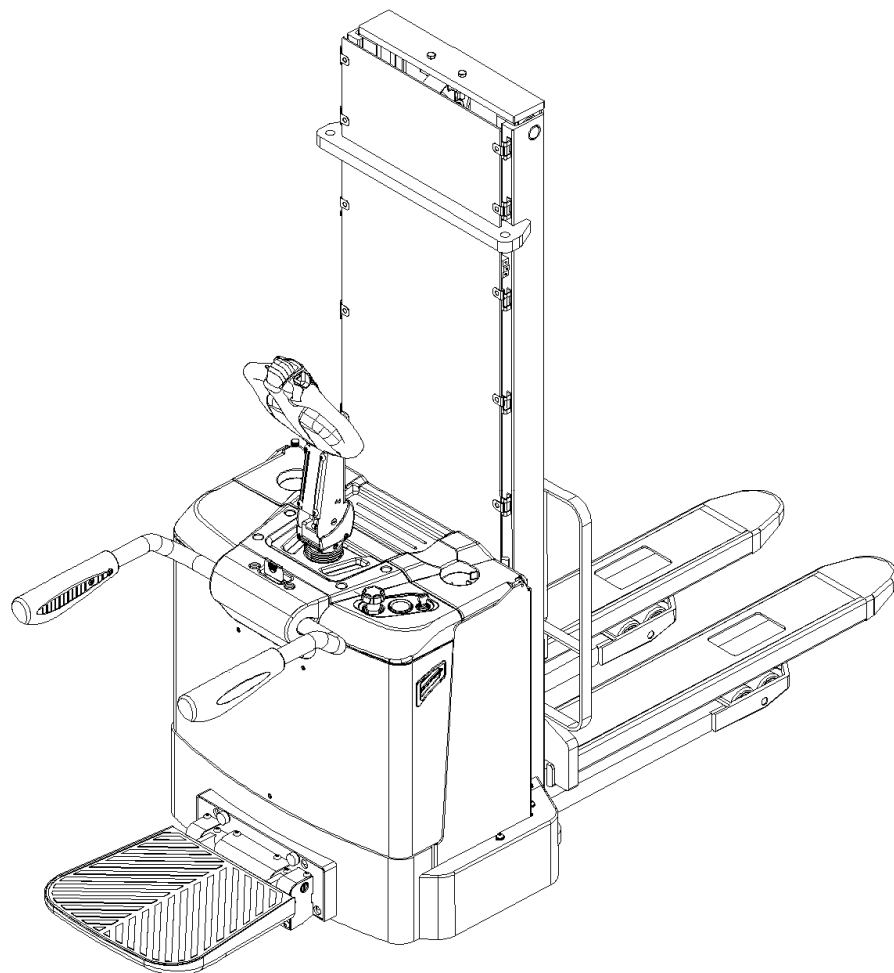

Version 10/2014

From truck identification number:

30130700011

PS B12-BPT-004-EN



# Catalogue

FIG. 1 LABEL (FOR EU) .....	3
FIG. 2 LABEL (FOR US) .....	4
FIG. 3 OUTLINE.....	5
FIG. 4 PROTECTIVE ARM.....	7
FIG. 5 FOLDABLE PLATFORM .....	8
FIG. 6 BATTERY COVER ASSEMBLY.....	10
FIG. 7 CHASSIS .....	11
FIG. 8 STEERING WHEEL .....	12
FIG. 9 LOAD WHEEL.....	14
FIG. 10 MAST ASSEMBLY(PS B12S ONE-STAGE MAST).....	15
FIG. 11 MAST ASSEMBLY(PS B12D TWO-STAGE MAST LIFT) .....	17
FIG. 12 MAST ASSEMBLY(PS B12F TWO-STAGE MAST FULL-FREE-LIFT).....	19
FIG. 13 ELECTRONIC CONTROL ASSEMBLY(MANUAL STEERING).....	21
FIG. 14 ELECTRONIC CONTROL ASSEMBLY(ELECTRICAL STEERING) .....	23
FIG. 15 MAIN HARNESS(MANUAL STEERING).....	25
FIG. 16 MAIN HARNESS(ELECTRICAL STEERING) .....	26
FIG. 17 ELECTRIC PARTS(MANUAL STEERING).....	27
FIG. 18 ELECTRIC PARTS(ELECTRICAL STEERING) .....	29
FIG. 19 POWER SUPPLY ASSEMBLY .....	31
FIG. 20 BATTERY .....	33
FIG. 21 HYDRAULIC SYSTEM(PS B12S ONE-STAGE MAST) .....	34
FIG. 22 CYLINDER(PS B12S ONE-STAGE MAST).....	36
FIG. 23 PUMP SYSTEM .....	38
FIG. 24 HYDRAULIC SYSTEM(PS B12D TWO-STAGE MAST LIFT) .....	40
FIG. 25 CYLINDER(PS B12D TWO-STAGE MAST LIFT).....	44
FIG. 26 HYDRAULIC SYSTEM(PS B12F TWO-STAGE MAST FULL-FREE-LIFT).....	46
FIG. 27 CYLINDER(PS B12F TWO-STAGE MAST FULL-FREE-LIFT) .....	50
FIG. 28 DRIVE SYSTEM(MANUAL STEERING) .....	52
FIG. 29 DRIVE WHEEL(43EL).....	54
FIG. 30 DRIVE SYSTEM(ELECTRICAL STEERING).....	58

FIG. 31 DRIVE WHEEL(23EL).....60  
FIG. 32 INSTRUMENT COMPONENTS .....62  
FIG. 33 TILLER ARM ASSEMBLY.....64  
FIG. 34 TILLER HEAD .....66  
EASY WORN PARTS LIST .....68

Fig. 1 Label (for EU)

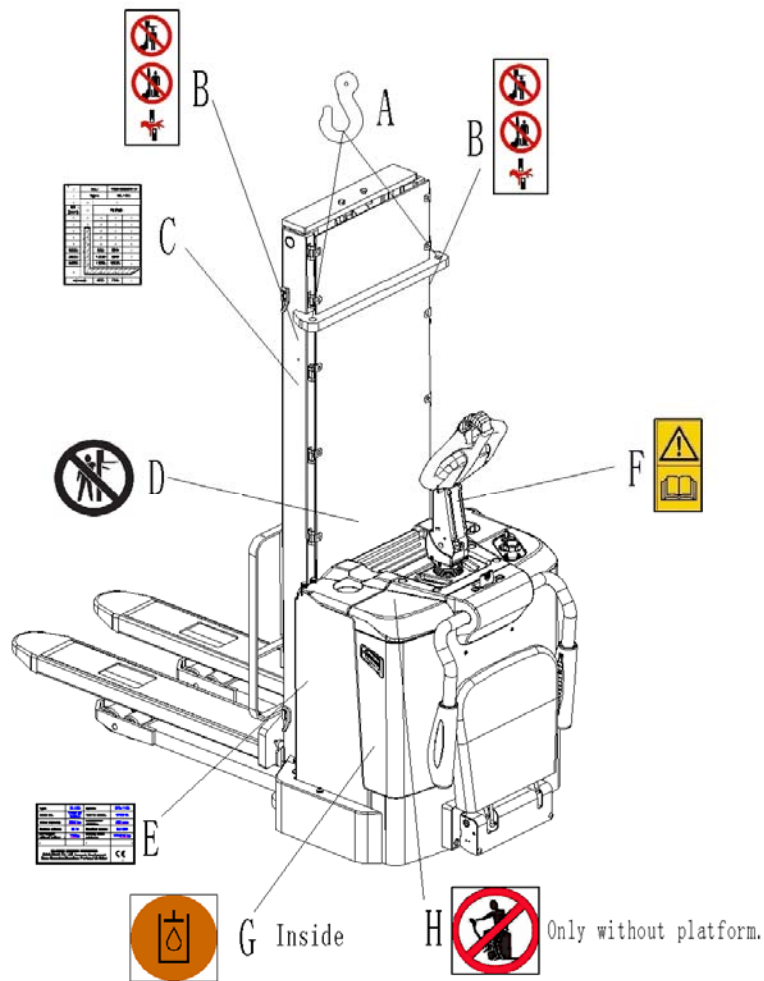

Fig. 1 Label (for EU)

No.	Parts No.	Item	Qty.	Note	Standard
A	9000005967	Crane hook label	2		
B	9000003923	Warning decal: Do not step under or on the forks	2		
C	9000008664	Residual lift capacity sticker	1		
D	9000008561	Never reach through	1		
E	9000008663	Identification plate	1		
F	9000003570	Sticker to read and follow these instructions	1		
G	9000008555	Filling sticker	1		
H	9000003573	'No passengers' decal	1		

Fig. 2 Label (for US)

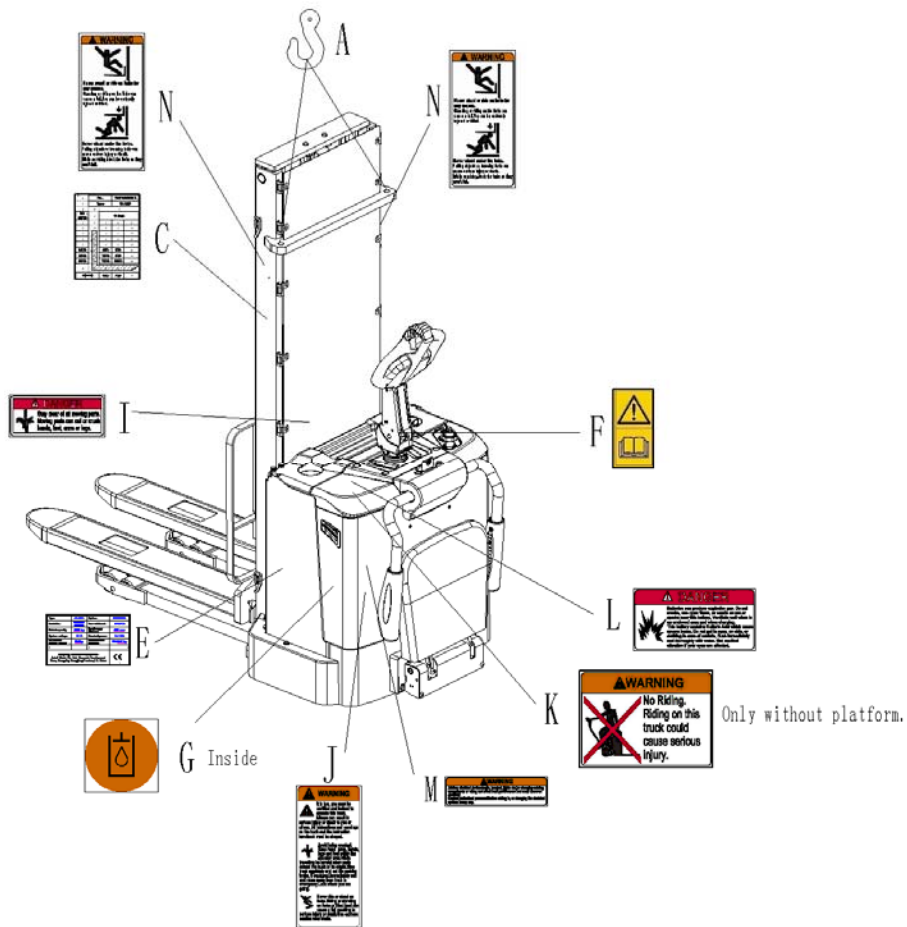
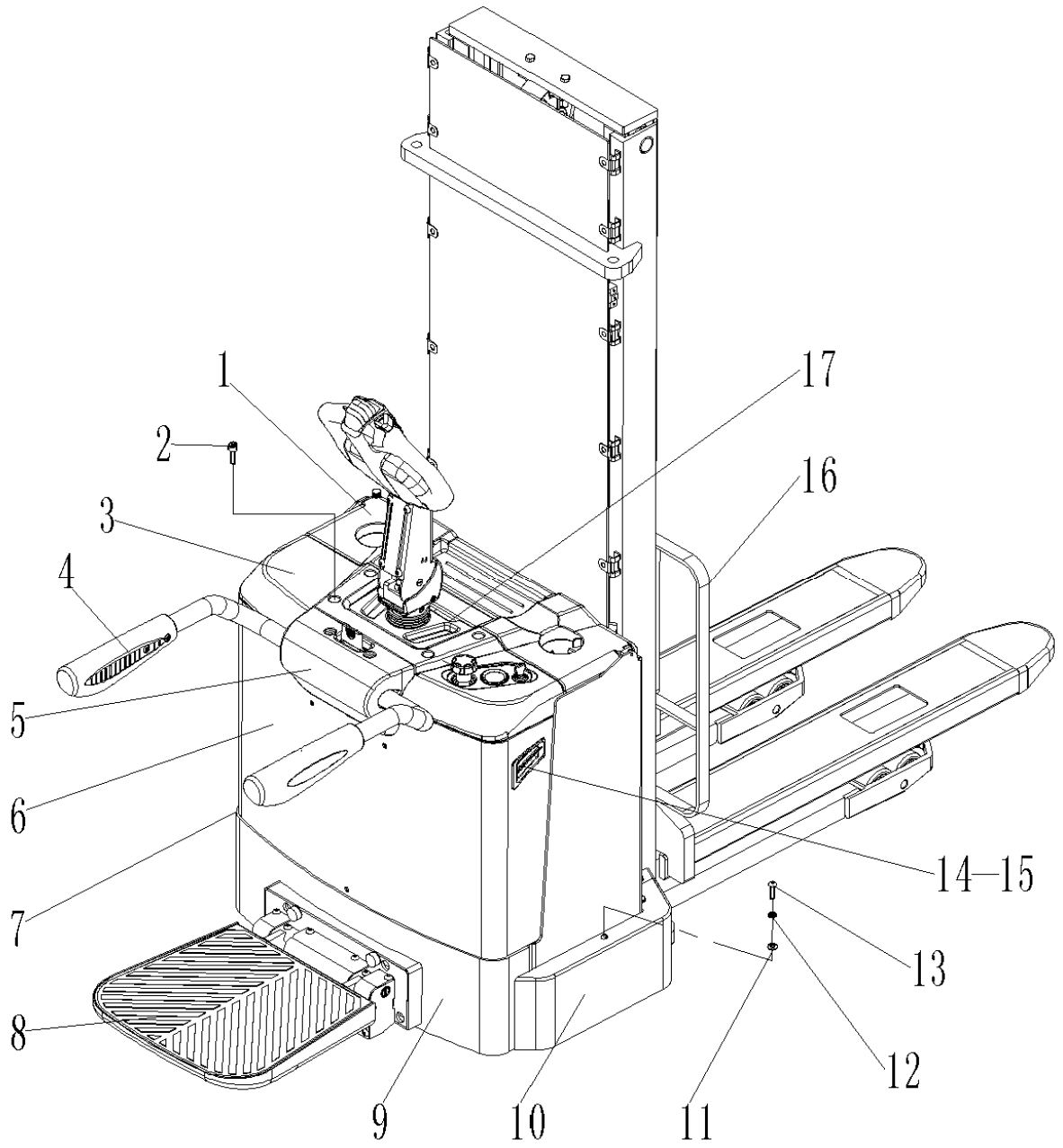

Fig. 2 Label (for US)

No.	Parts No.	Item	Qty.	Note	Standard
A	9000005967	Crane hook label	2		
C	9000008664	Residual lift capacity sticker	1		
E	9000008663	Identification plate (ID-plate)	1		
F	9000003570	Sticker to read and follow these instructions	1		
G	9000008555	Filling sticker	1		
I	9000005970	Warning label	1		
J	9000003575	Warning label	1		
K	9000003580	Warning label	1		
L	9000003577	Warning label	1		
M	9000003579	Warning label	1		
N	9000005971	Warning label	2		

Fig. 3 Outline



**Fig. 3 Outline**

No.	Art No.	Description	Qty.	Note	Standard
1	9000008128	Battery cover	1		
2	1000423003	Screw	8	M10×30	
3	9000008129	Upper cover	1		
4	9000007891	Protective arm assembly	1		
5	9000008063	Protective arm cover	1		
6	9000008126	Welded main cover	1		
7	9000008132	Welded left wheel cover	1		
8	9000007862	Foot pedal assembly	1		
9	9000008125	Welded truck body	1		
10	9000008136	Welded right wheel cover	1		
11	0000025002	Washer	6	10	GB/T95
12	0000023006	Washer	6	10	GB/T93
13	0000023857	Screw	6	M10×20	GB/T70.2=ISO7380
14	9000007920	Left vent components	1		
15	9000007923	Right vent components	1		
16	9000008259	Load backrest assembly	1		
17	9000008130	Middle cover	1		

Fig. 4 Protective arm

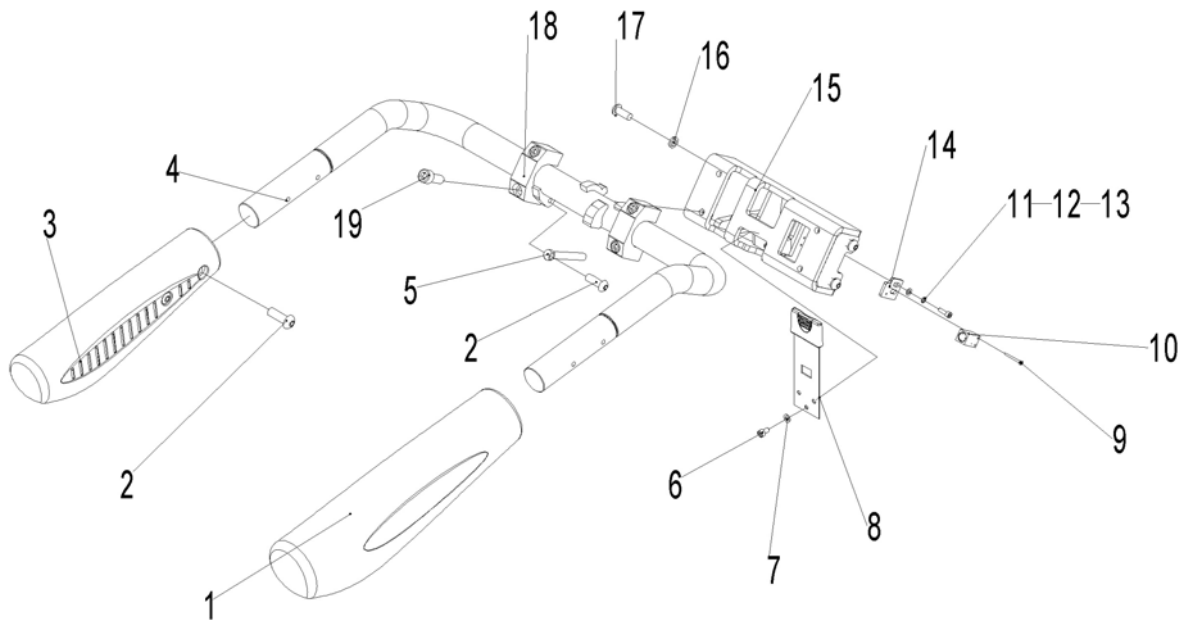
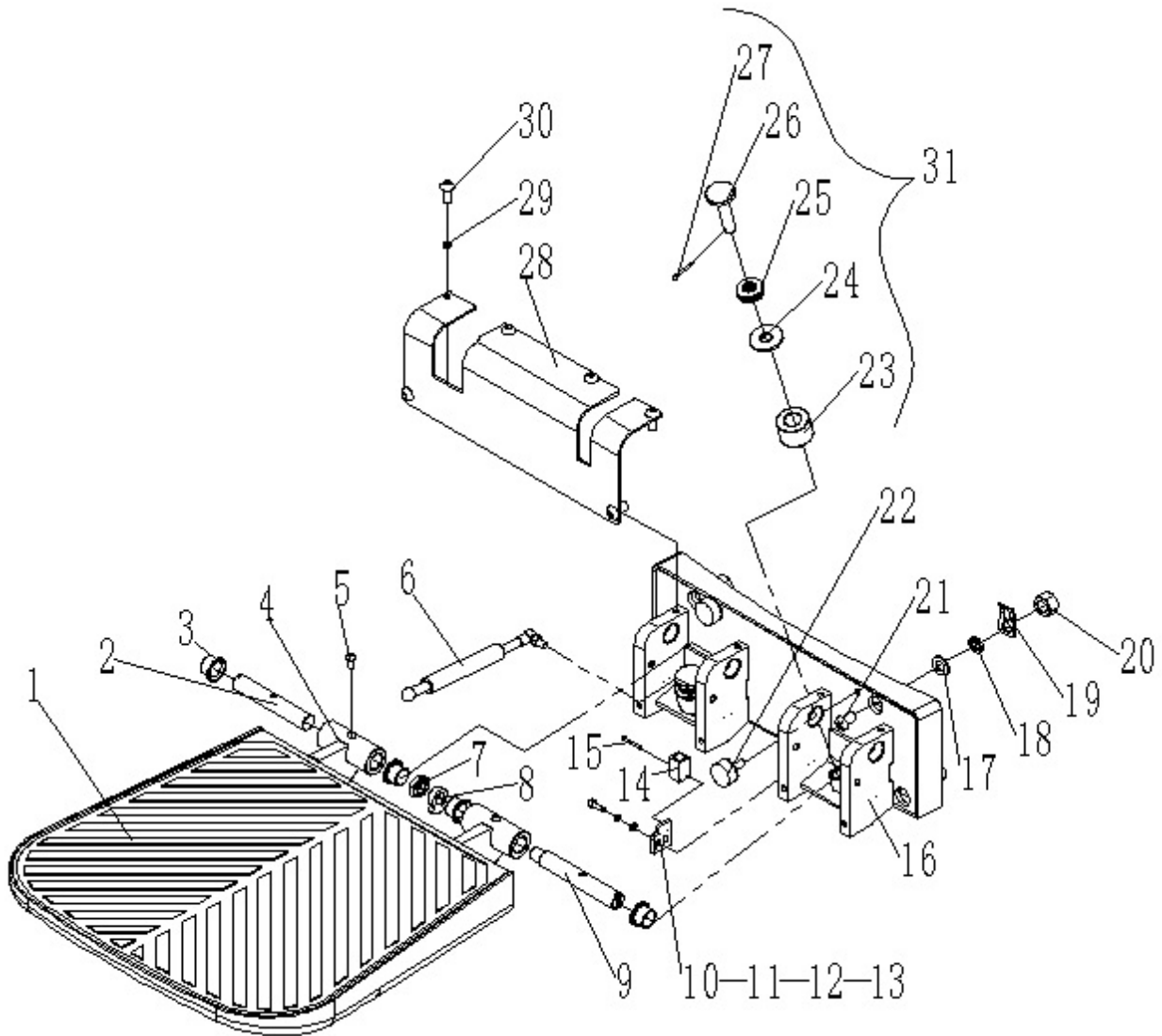

Fig. 4 Protective arm

No.	Art No.	Description	Qty.	Note	Standard
1	9000007895	Right protective arm cover	1		
2	0090000448	Screw	5	M8×20	GB/T70.2=ISO7380
3	9000007896	Left protective arm cover	1		
4	9000007894	Welded protective arm	1		
5	9000007780	Air spring	1		
6	0000023045	Screw	3	M6×12	GB/T70.2=ISO7380
7	0000025010	Washer	3	6	GB/T93
8	9000007897	Positioning spring	1		
9	0000023075	Screw	2	M3×20	GB/T70.1=ISO4762
10	9000008329	Proximity switch	1	NBN5-F7-E5	
11	0000025012	Washer	2	5	GB/T93
12	0000023032	Washer	2	5	GB/T95
13	0000023107	Screw	2	M5×16	GB/T70.1=ISO4762
14	9000009799	Switch transition plate	1		
15	9000007892	Welded protective arm seat	1		
16	0000023006	Spring washer	4	10	GB/T93
17	0090000447	Screw	4	M10×25	GB/T70.2=ISO7380
18	9000007893	Protective arm clamp block	2		
19	0000023099	Screw	4	M10×45	GB/T70.1=ISO4762

Fig. 5 Foldable platform





**Fig. 5 Foldable platform**

No	Art No.	Description	Qty.	Note	Standard
1	9000007867	Pedal pad	1		
2	9000007869	Rotating shaft	1		
3	9000007799	Shoulder harness	4	Ø20×Ø23×16.5	
4	9000007863	Welded foot platform	1		
5	0000023555	Screw	2	M6×16	GB/T70.2=ISO7380
6	2000421001	Air spring	1		
7	0000024014	Nut	1	M16×1.5	GB/T6173 =ISO8675
8	9000007873	Cam	1		
9	9000007866	Cam shaft	1		
10	0000025012	Washer	2	5	GB/T93
11	0000023032	Washer	2	5	GB/T95
12	0000023107	Screw	2	M5×16	GB/T70.1=ISO4762
13	9000009799	Switch transition plate	1		
14	9000008328	Proximity switch	1	NBN5-F7-E5	
15	0000023075	Screw	2	M3×20	GB/T70.1=ISO4762
16	9000007864	Welded assembly seat	1		
17	0090000048	Washer	4	12	GB/T97.1
18	0000025024	Washer	4	12	GB/T93
19	9000007874	Line hanging board	1		
20	0000024006	Lock nut	4	M12	GB/T889.1=ISO7040
21	0090000450	Screw	4	M12×45	GB/T70.2=ISO7380
22	9000007865	Damping pad	2		
23	9000007872	Anti-vibration pad	2		
24	9000007871	Anti-vibration washer	2		
25	0000031001	Disc spring	8	Ø16.3×Ø31.5×1.75	GB/T1972
26	9000007870	Fixed bolt	2		
27	0000028033	Split pin	2	Ø3.2×20	GB/T91
28	9000007868	Assembly seat cover	1		
29	0000025010	Washer	6	6	GB/T93
30	0000023045	Screw	6	M6×12	GB/T70.2=ISO7380
31	9000008897	Suspension components	2		

Fig. 6 Battery cover assembly

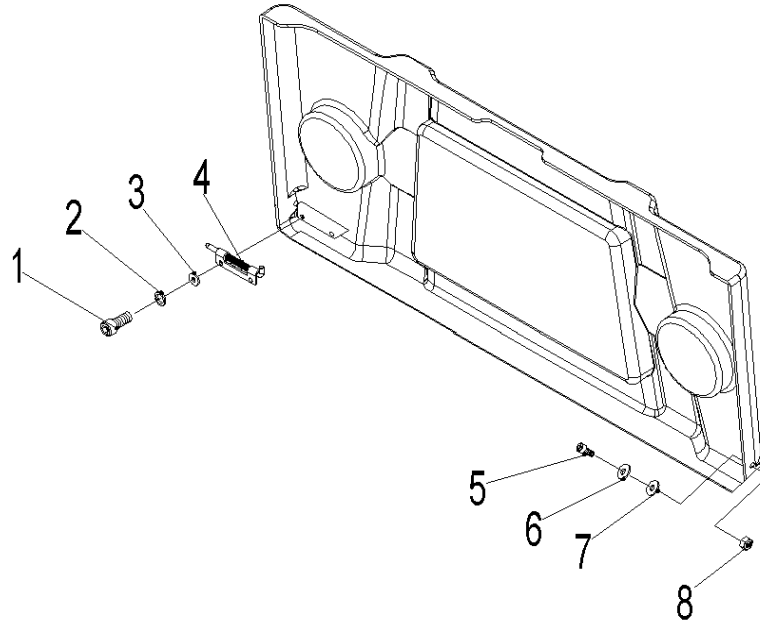

Fig. 6 Battery cover assembly

No.	Art No.	Description	Qty.	Note	Standard
1	0000023073	Screw	2	M4×10	GB/T70.1=ISO4762
2	0000025018	Washer	2	4	GB/T93
3	0000025019	Washer	2	4	GB/T95
4	9000008795	Latch	1	CL037	
5	0000023306	Screw	1	M5×20	GB/T70.1=ISO4762
6	0000025015	Washer	1	5	GB/T93
7	0000025014	Washer	1	5	GB/T95
8	0000024035	Nut	1	M5	GB/T6170

Fig. 7 Chassis

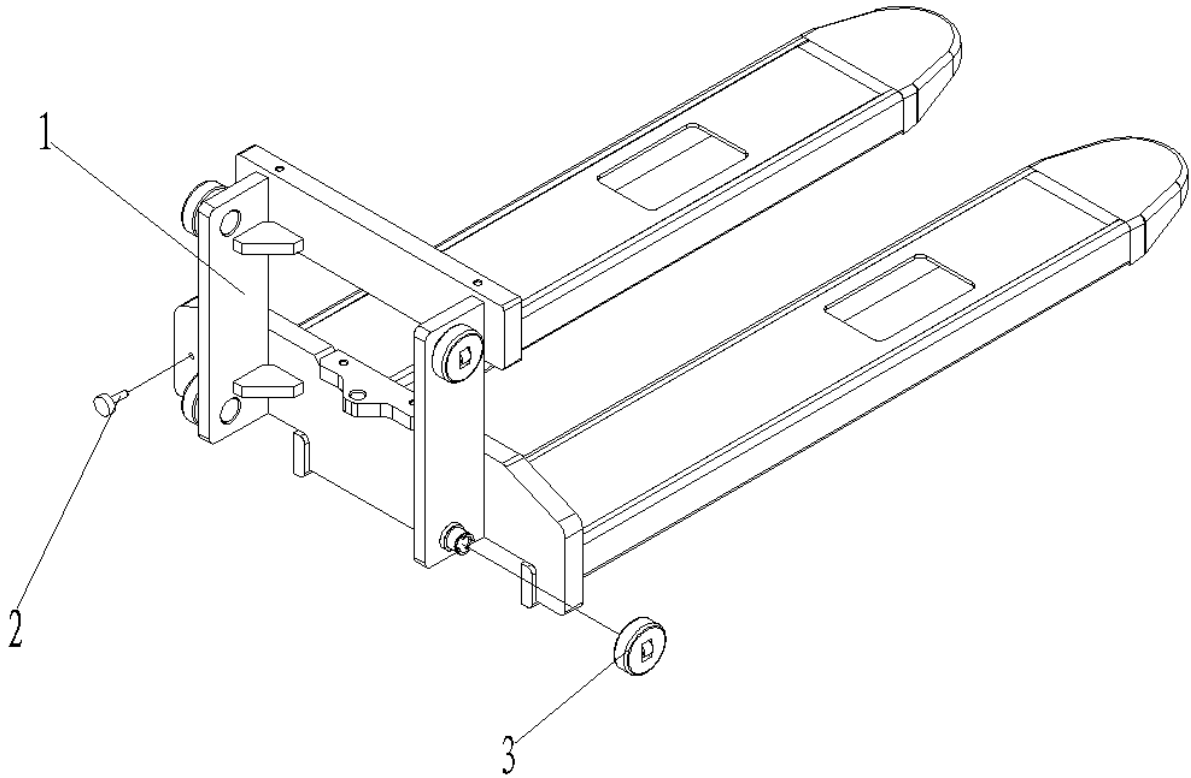
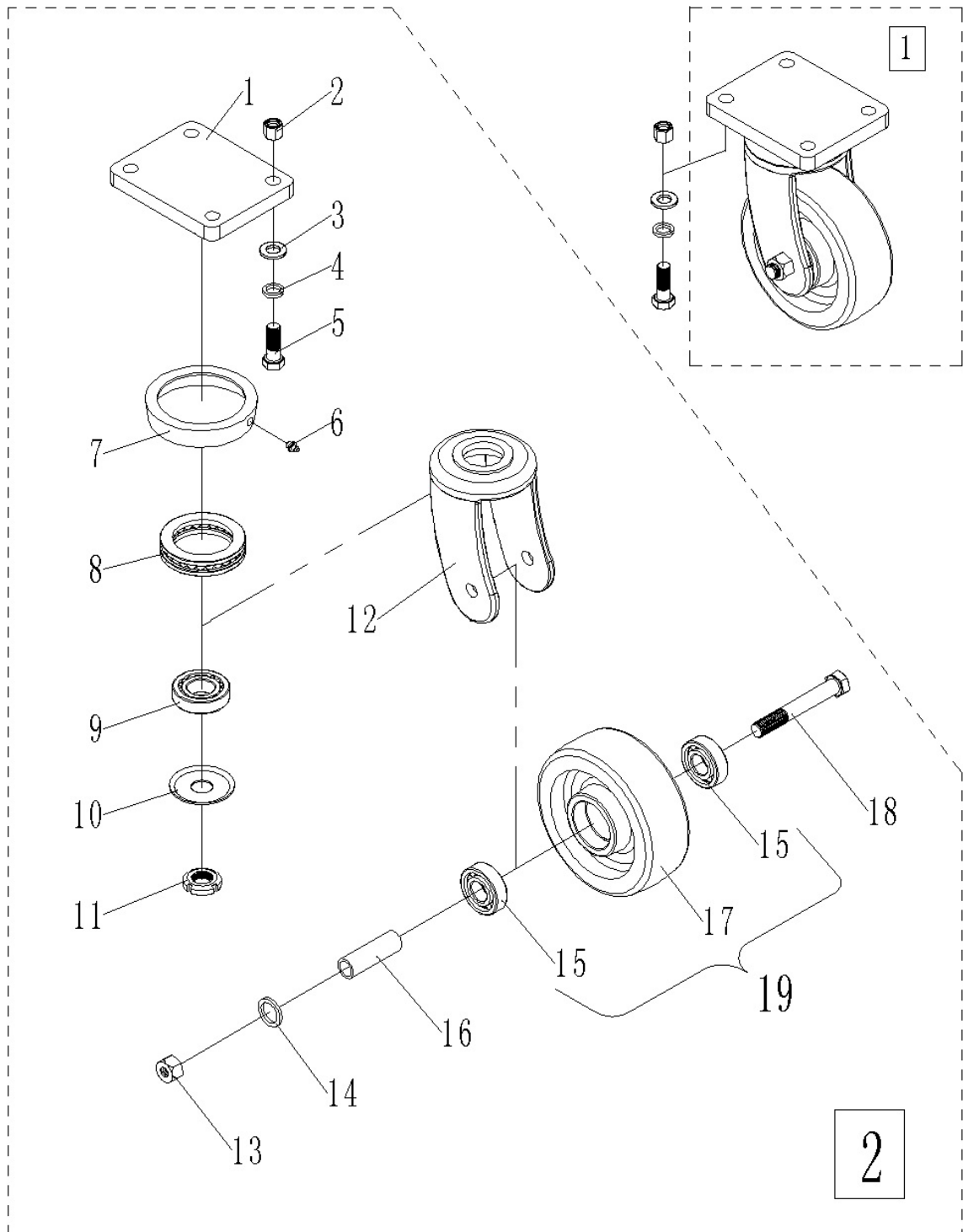

Fig. 7 Chassis

No.	Art No.	Description	Qty.	Note	Standard
1	9000009351	Welded chassis (570X1150)	1	one-stage mast	
	9000009352	Welded chassis (685X1150)	1	one-stage mast	
	9000008108	Welded chassis (570X1150)	1	two-stage mast	
	9000009144	Welded chassis (570X1150)	1	two-stage mast	
2	2000435002	Magnet steel	1		
3	9000007754	Compound roller	4		

Fig. 8 Steering wheel



**Fig. 8 Steering wheel**

No.	Art No.	Description	Qty.	Note	Standard
1	2240401006	Welded flange	2		
2	0000024006	Lock nut	8	M12	GB/T889.1=ISO7040
3	0000025032	Washer	8	12	GB/T95
4	0000025024	Washer	8	12	GB/T93
5	0000023122	Screw	8	M12×50	GB/T70.1=ISO4762
6	0000030002	Oil cup	2	M6	JB/T7940.1
7	2210422001	Dust ring	2		
8	0000027014	Bearing	2	8111	GB/T301
9	0000027015	Bearing	2	7205E	GB/T297
10	2210404001	Pressing cover	2		
11	0000024016	Round nut	2	M20×1.5	GB/T812
12	2210405001	Frame of roller	2		
13	0000024015	Lock nut	2	M14	GB/T889.1=ISO7040
14	2210425001	Washer	4		
15	0000027001	Bearing	4	6204	GB/T276=ISO3290
16	2210413001	Shaft sleeve	2		
17	2210416001	Castor	2		
18	0000023111	Bolt	2	M14×100	GB/T5782=ISO4014
19	9000008896	Wheel set	1		
①	2210400001	Steering wheel components	2		
②	9000010410	Steering wheel accessories	2		

Fig. 9 Load wheel

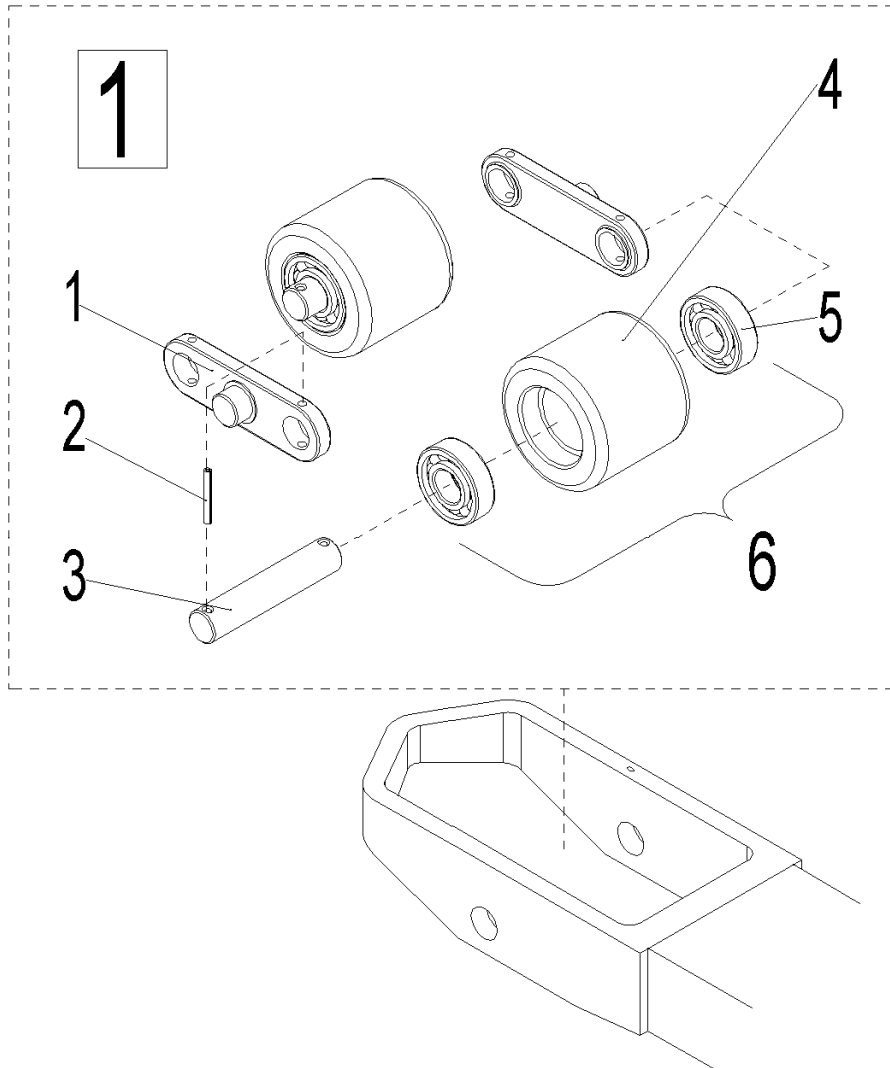
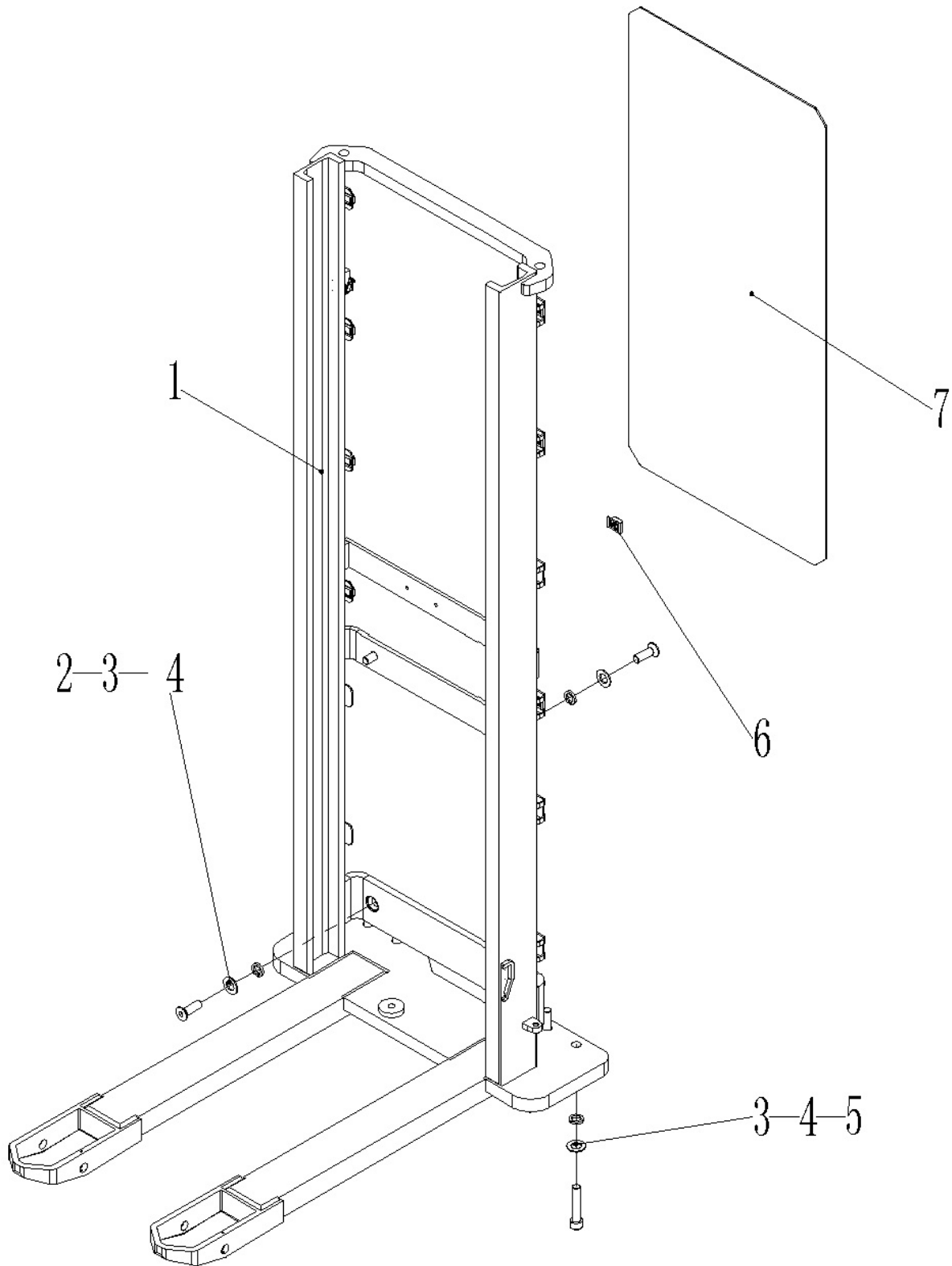

Fig. 9 Load wheel

No.	Art No.	Description	Qty.	Note	Standard
1	2000405002	Connecting plate	2		
2	0000028009	Dowel pin	4	∅5×35	GB/T879.1
3	2000407001	Shaft for load roller	2		
4	2000416002	Load roller	2	∅80×70	
5	0000027001	Bearing	4	6204	GB/T276=ISO3290
6	9000010398	Small wheel set	2		
①	2000600001	Load roller assembly	2		

Fig. 10 Mast assembly(PS B12S One-stage mast)

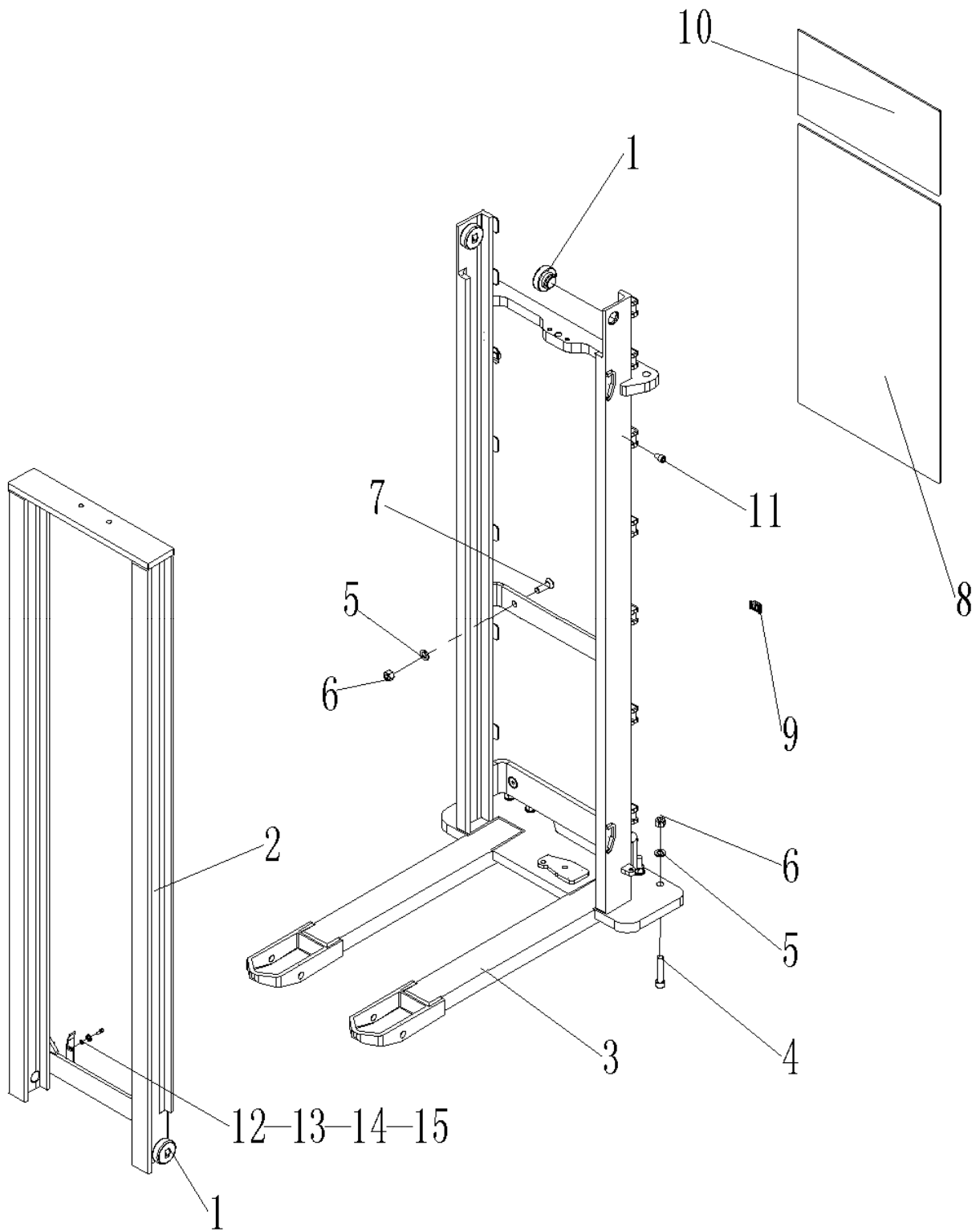

**Fig. 10 Mast Assembly(PS B12S One-stage mast)**

No.	Art No.	Description	Qty.	Note	Standard
1	9000009353	Welded mast	1	1600;570×1150	
	9000009354			1600;685×1150	
2	2210423001	Screw	4	M16×52	
3	0000025029	Washer	8	16	GB/T95
4	0000024011	Lock nut	8	M16	GB/T889.1=ISO7040
5	0090000486	Screw	4	M16×80	GB/T70.1=ISO4762
6	9000007782	Spring card buckle	8	1	
7	9000009355	Protective glass	1	1600	



Fig. 11 Mast assembly(PS B12D Two-stage mast Lift)



**Fig. 11 Mast Assembly(PS B12D Two-stage mast Lift)**

No.	Art No.	Description	Qty.	Note	Standard
1	9000007753	Compound roller	4		
2	9000008122	Welded inner mast	1	3200	
	9000008122			2900	
	9000009133			3600	
	9000009137			2600	
3	9000008121	Welded outer mast	1	3200;570×1150	
	9000008121			2900;570×1150	
	9000009132			3600;570×1150	
	9000009136			2600;570×1150	
	9000009140			3200;685×1150	
	9000009141			2900;685×1150	
	9000009142			3600; 685×1150	
	9000009143			2600; 685×1150	
4	0090000486	Screw	4	M16×80	GB/T70.1=ISO4762
5	0000025029	Washer	8	16	GB/T95
6	0000024011	Lock nut	8	M16	GB/T889.1=ISO7040
7	2210423001	Screw	4	M16×52	
8	9000008111	Protective glass	1	3200	
	9000008123			2900	
	9000009134			3600	
	9000009138			2600	
9	9000007782	Spring buckle	10		
10	9000008119	Top glass	1		
11	0090000189	Screw	1	M4x8	GB/T70.3
12	9000008112	Limit board	1		
13	0000023853	Screw	2	M4x15	GB/T70.1=ISO4762
14	0000025018	Washer	2	4	GB/T93
15	0000025019	Washer	2	4	GB/T95

Fig. 12 Mast assembly(PS B12F Two-stage mast Full-Free-Lift)

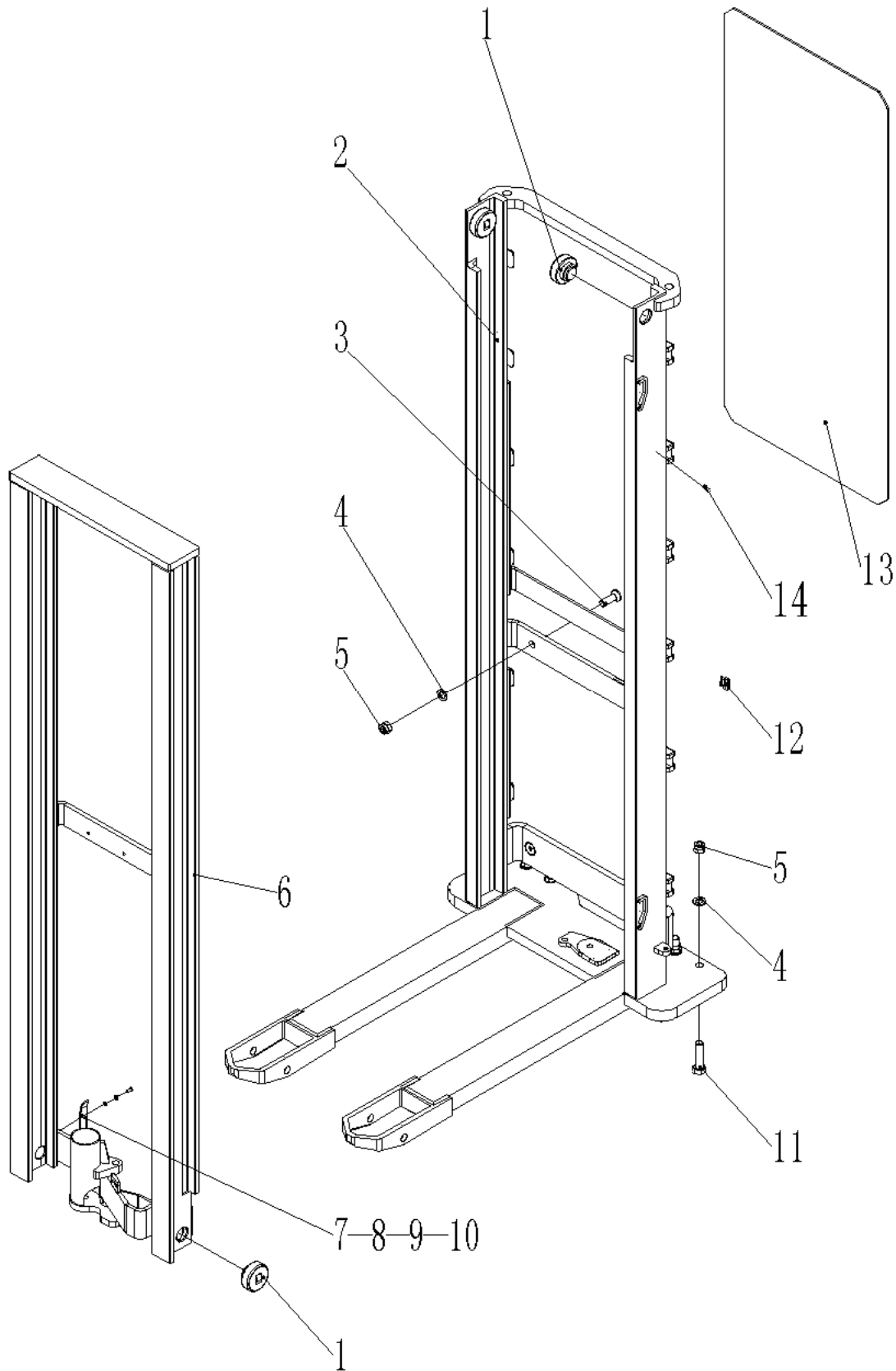

**Fig.12 Mast Assembly(PS B12F Two-stage mast Full-Free-Lift)**

No.	Art No.	Description	Qty.	Note	Standard
1	2240611001	Composite roller	4		
2	9000009084	Welded outer mast	1	3200;570×1150	
	9000009091			2900;570×1150	
	9000009095			3200;685×1150	
	9000009096			2900;685×1150	
3	2210423001	Screw	4	M16×52	
4	0000025029	Washer	8	16	GB/T95
5	0000024011	Lock nut	8	M16	GB/T889.1=ISO7040
6	9000009085	Welded inner mast	1	3200	
	9000009092	Welded inner mast	1	2900	
7	9000008112	Limit board	1		
8	0000023853	Screw	2	M4×16	GB/T70.1=ISO4762
9	0000025009	Washer	2	4	GB/T93
10	0000025019	Washer	2	4	GB/T95
11	0090000486	Screw	4	M16×80	GB/T70.1=ISO4762
12	9000007782	Spring buckle	8	thick 1	
13	9000009090	Protective glass	1	3200	
	9000009093			2900	
14	0090000189	Screw	1	M4x8	GB/T70.3

Fig. 13 Electronic control assembly(manual steering)

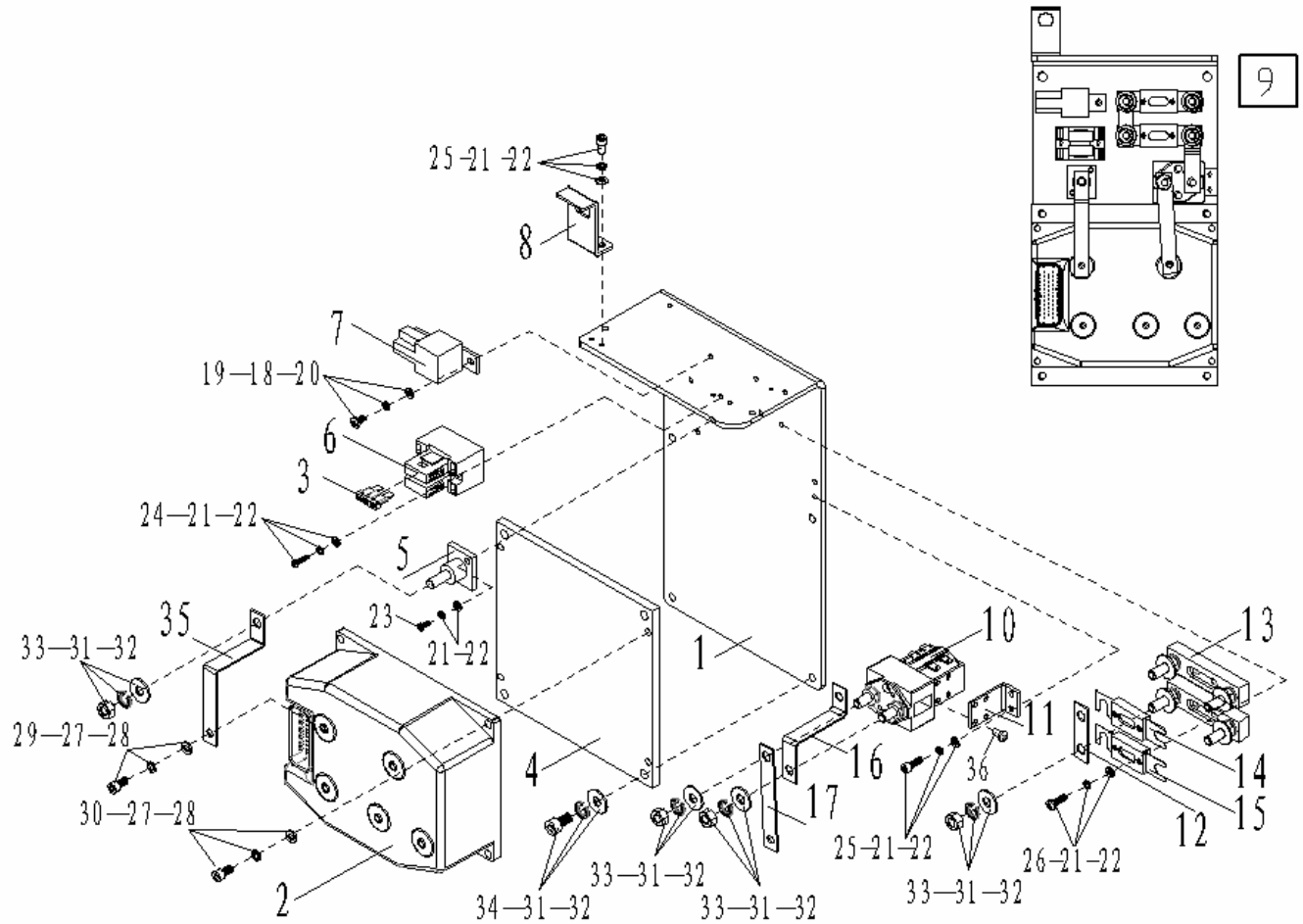

Fig. 13 Electronic control assembly(manual steering)

No.	Art No.	Description	Qty.	Note	Standard
1	9000008138	Controller plate	1		
2	9000000235	CURTIS Controller	1	1232E-2121	
3	1000434040	Fuse	1	10A	

4	9000008376	Aluminium plate	1		
5	1020434002	Wiring terminal	1	BD-M8	
6	9000008586	Fuse seat	1	BD-2×10A	
7	1000434041	Pump contactor	1	DC24V	
8	9000008585	Plug fixing plate	1		
9	9000008409	Controller components	1		
10	1000434006	Traction motor contactor	1	DC24V	
11	9000008598	Main contactor assemble plate	1		
12	1020434003	Copper bar	1		
13	9000007679	Fuse seat	2	SY Y	
14	1020434001	Fuse	1	200A	
15	2210434004	Fuse	1	150A	
16	9000008374	Copper bar	1		
17	9000008373	Copper bar	1		
18	0000023516	Screw	3	M5×10	GB/T818=ISO7045
19	0000025015	Washer	1	5	GB/T93-
20	0000025014	Washer	1	5	GB/T95
21	0000025018	Washer	12	4	GB/T93
22	0000025019	Washer	12	4	GB/T95
23	0000023073	Screw	2	M4×10	GB/T818=ISO7045
24	0000023019	Screw	2	M4×30	GB/T818=ISO7045
25	0000023307	Screw	4	M4×10	GB/T818=ISO7045
26	0000023211	Screw	4	M4×16	GB/T818=ISO7045
27	0000025010	Washer	9	6	GB/T93
28	0000023055	Washer	9	6	GB/T95
29	0000023478	Screw	5	M6×12	GB/T70.1=ISO4762
30	0000023923	Screw	4	M6×18	GB/T70.1=ISO4762
31	0000025001	Washer	11	8	GB/T93
32	0000025011	Washer	11	8	GB/T95
33	0000024086	Nut	11	M8	GB/T6170
34	0000023067	Screw	4	M8×16	GB/T70.1=ISO4762
35	9000008372	Copper bar	1		
36	0000023727	Screw	2	M4×6	GB/T818=ISO7045

Fig. 14 Electronic control assembly(electrical steering)

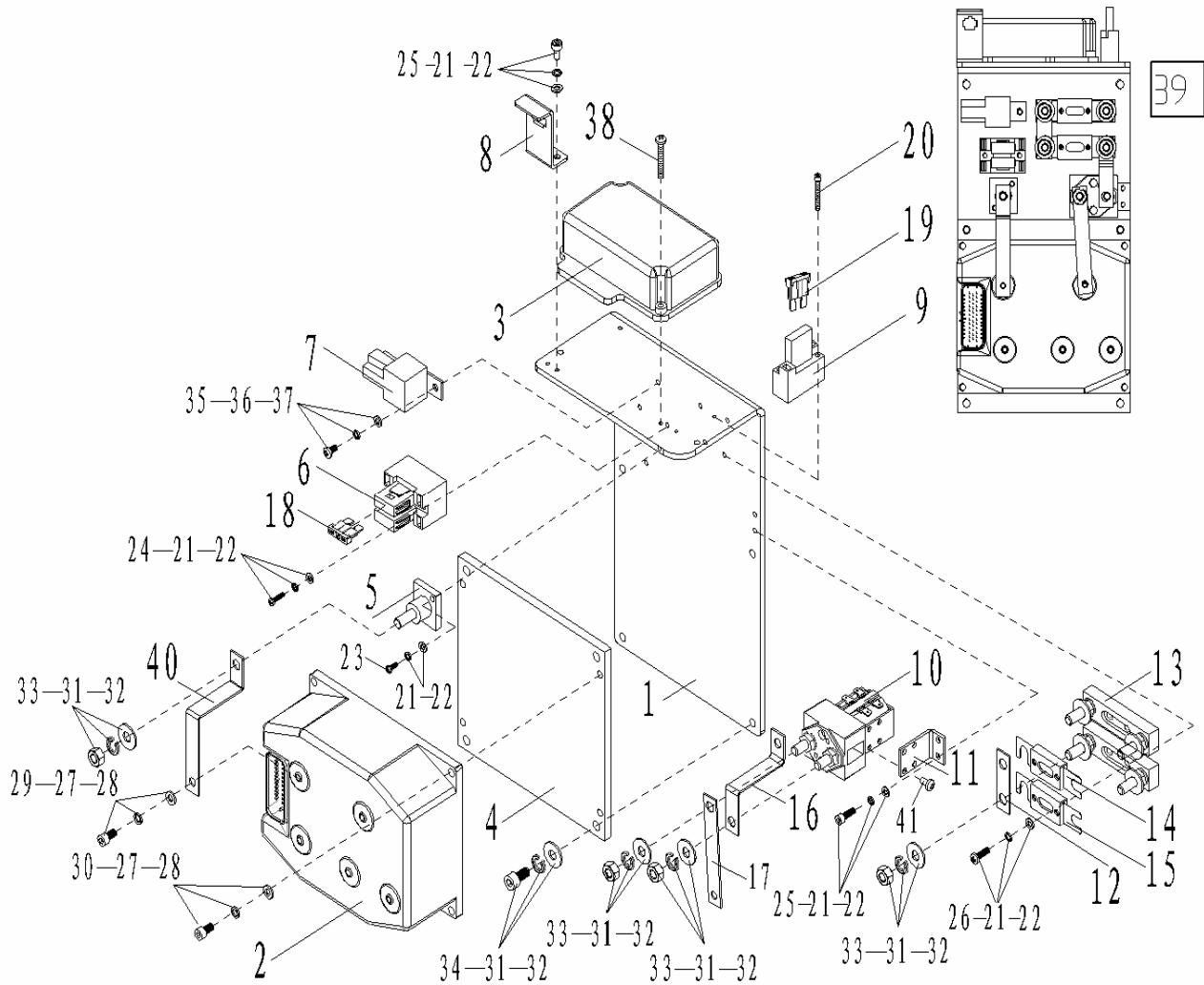

Fig. 14 Electronic control assembly(electrical steering)

No.	Art No.	Description	Qty.	Note	Standard
1	9000008138	Controller assemble plate	1		
2	9000000235	Controller	1	CURTIS1232E-2121	
3	9000000236	Steering controller	1	BD-SC-24/10	
	9000008451			BD-SC-24/10-3	
4	9000008376	Aluminium plate	1		
5	1020434002	Wiring terminal	1	BD-M8	
6	9000008586	Fuse seat	1	BD-2×10A-1	
7	1000434041	Pump contactor	1	DC24V	

8	9000008585	Plug fixing plate	1		
9	1000434021	Fuse seat	1	BD-1×10A	
10	1000434006	Traction motor contactor	1	DC24V	
11	9000008598	Main contactor assembly plate	1		
12	1020434003	Copper bar	1		
13	9000007679	Fuse seat	2	SY Y	
14	1020434001	Fuse	1	200A	
15	2210434004	Fuse	1	150A	
16	9000008374	Copper bar	1		
17	9000008373	Copper bar	1		
18	1000434040	Fuse	1	10A	
19	3042434014	Fuse	1	15A	
20	0000023070	Screw	2	M3×25	GB/T70.1=ISO4762
21	0000025018	Washer	12	4	GB/T93
22	0000025019	Washer	12	4	GB/T95
23	0000023073	Screw	2	M4×10	GB/T70.1=ISO4762
24	0000023019	Screw	2	M4×30	GB/T818=ISO7045
25	0000023307	Screw	4	M4×10	GB/T818=ISO7045
26	0000023211	Screw	4	M4×16	GB/T818=ISO7045
27	0000025010	Washer	9	6	GB/T93
28	0000023055	Washer	9	6	GB/T95
29	0000023478	Screw	5	M6×12	GB/T70.1=ISO4762
30	0000023923	Screw	4	M6×18	GB/T70.1=ISO4762
31	0000025001	Screw	12	8	GB/T93
32	0000025011	Washer	11	8	GB/T95
33	0000024086	Nut	12	M8	GB/T6170
34	0000023067	Screw	4	M8×16	GB/T70.1=ISO4762
35	0000023516	Screw	3	M5×10	GB/T818=ISO7045
36	0000025015	Washer	1	5	GB/T93
37	0000025014	Washer	1	5	GB/T95
38	0090000082	Screw	2	M4×30	GB/T70.1=ISO4762
39	9000008597	Electronic control components	1		
40	9000008372	Copper bar	1		
41	0000023727	Screw	2	M4×6	GB/T818=ISO7045



Fig. 15 Main harness(manual steering)

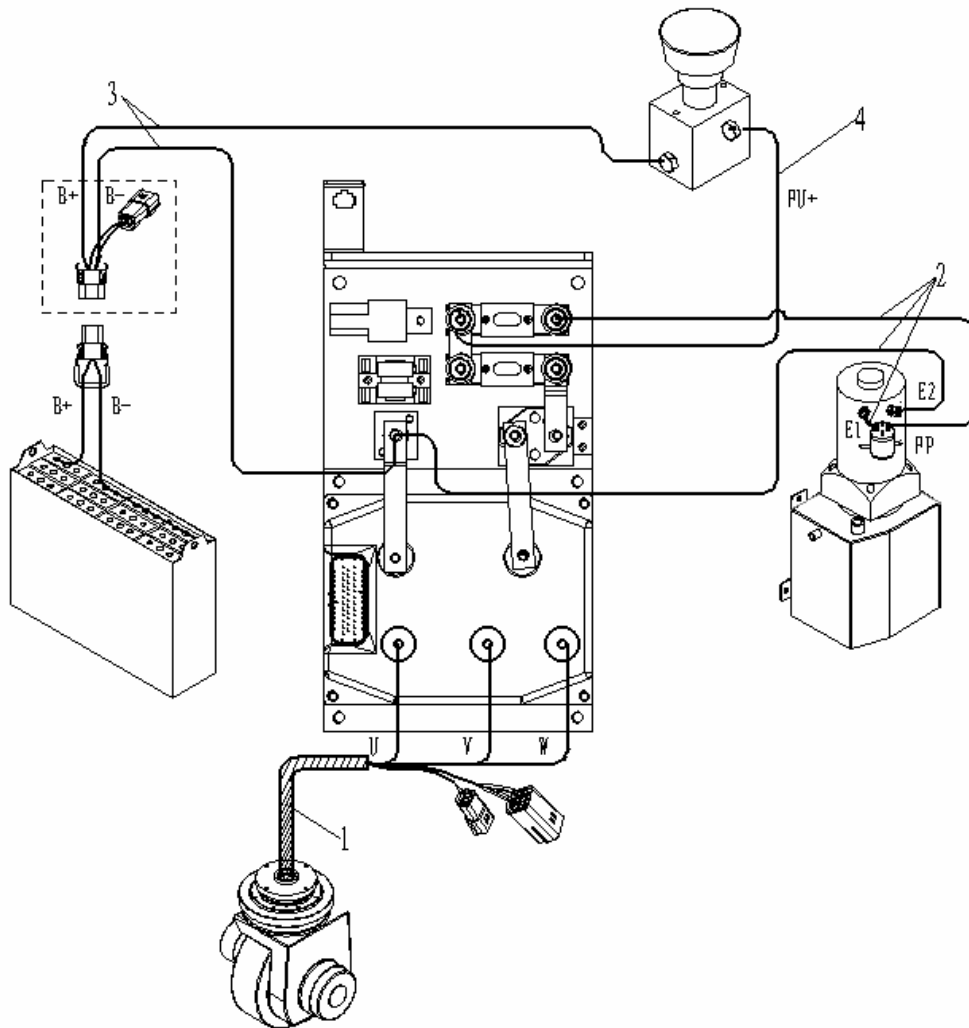
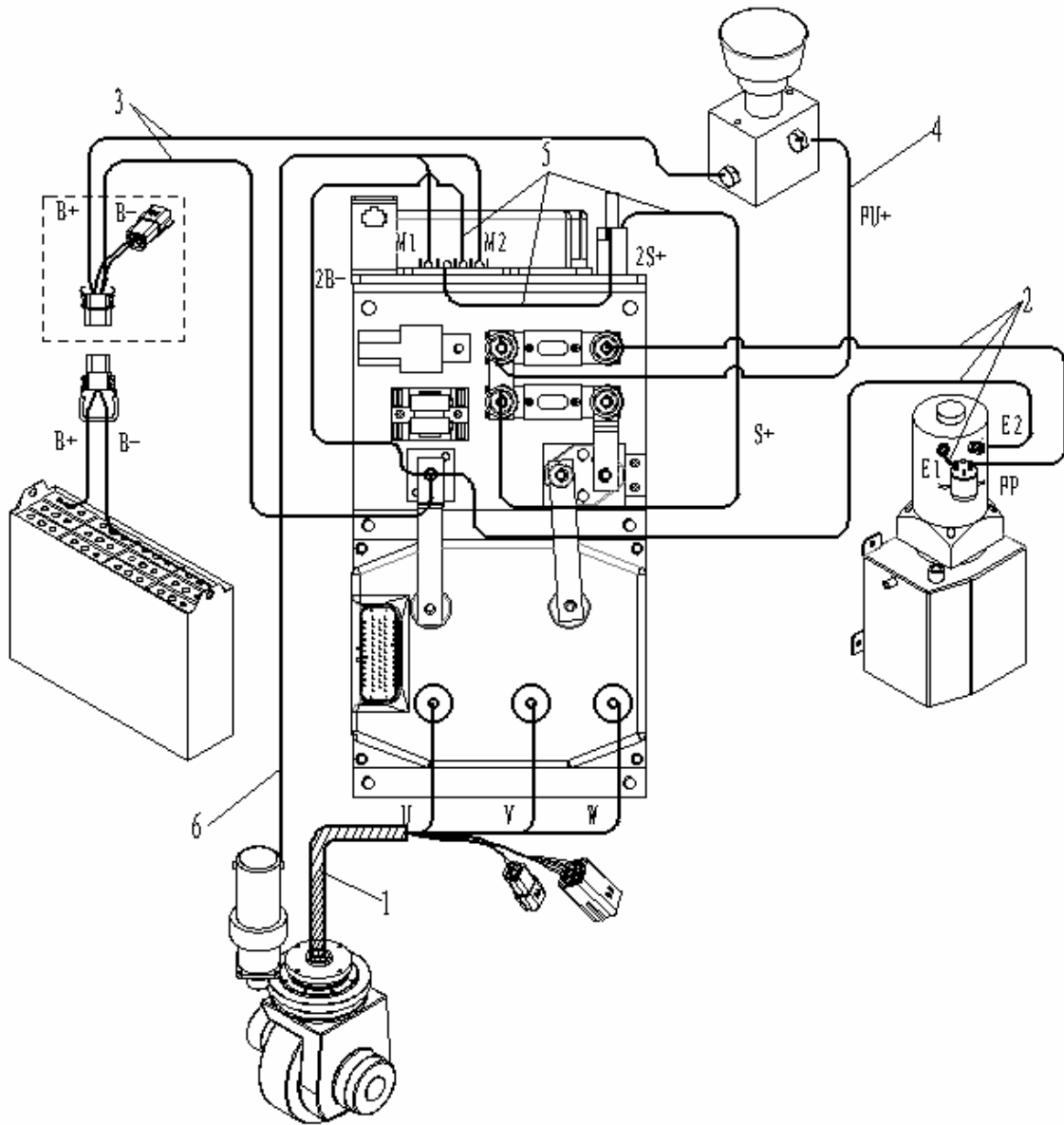

Fig. 15 Main Harness(manual steering)

No.	Art No.	Description	Qty.	Note	Standard
1	900008405	Drive motor cable	1		
2	900008406	Pump motor cable	1		
3	900008407	Power supply cable	1		
4	900008408	FU+ cable	1		

Fig. 16 Main harness(electrical steering)



**Fig. 16 Main Harness(electrical steering)**

No.	Art No.	Description	Qty.	Note	Standard
1	900008429	Drive motor cable	1		
2	900008430	Pump motor cable	1		
3	900008431	Power supply cable	1		
4	900008432	FU+ cable	1		
5	900008433	Steering controller cable	1		
6	900008434	Steering motor cable	1		

**Fig. 17 Electric parts(manual steering)**

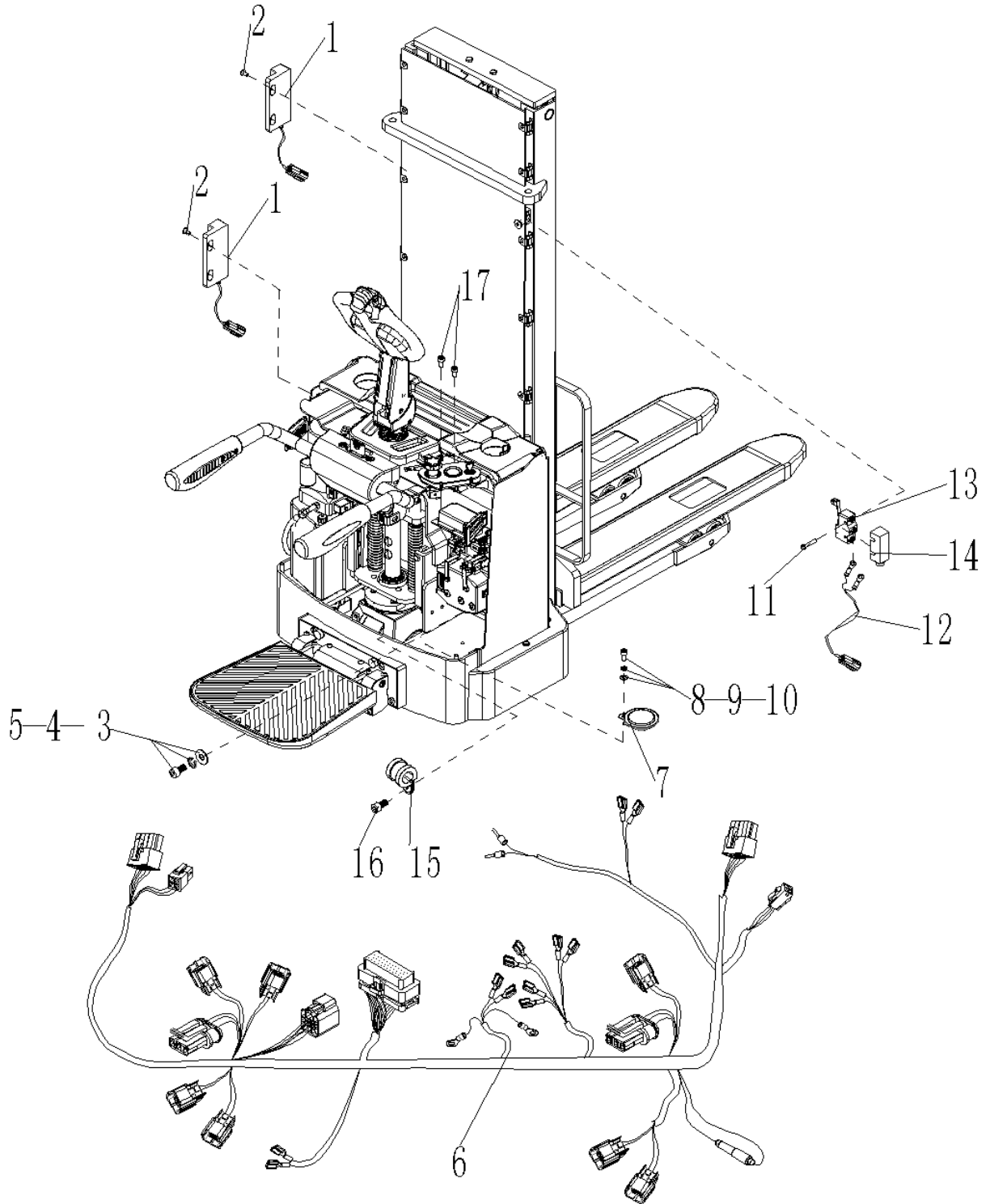

**Fig.17 Electric parts(manual steering)**

No.	Art No.	Description	Qty.	Note	Standard
1	9000008332	Magnet switch	2	HWK23	
2	0000023083	Screw	4	M3×8	GB/T70.2=ISO7380
3	0000023044	Screw	4	M8×20	GB/T70.1=ISO4762
4	0000025001	Washer	4	8	GB/T93
5	0000025011	Washer	4	8	GB/T97.1
6	9000008403	Main control wiring diagram	1		
7	1000434015	Horn	1	DC24V	
8	0000023478	Screw	1	M6×12	GB/T70.1=ISO4762
9	0000025010	Washer	1	6	GB/T93
10	0000023055	Washer	1	6	GB/T97.1
11	0000023033	Screw	2	M4×25	GB/T70.1=ISO4762
12	9000008404	Limit control wiring harness	1		
13	2040634001	Micro switch	1	XZ-15GW22-B	
14	2040603002	Micro switch cover	1		
15	9000009545	YGE hose clamp	1	26X20	
16	0000023042	Screw	1	M6×10	GB/T70.1=ISO4762
17	0000023106	Screw	2	M6×30	GB/T70.1=ISO4762

Fig. 18 Electric parts(electrical steering)

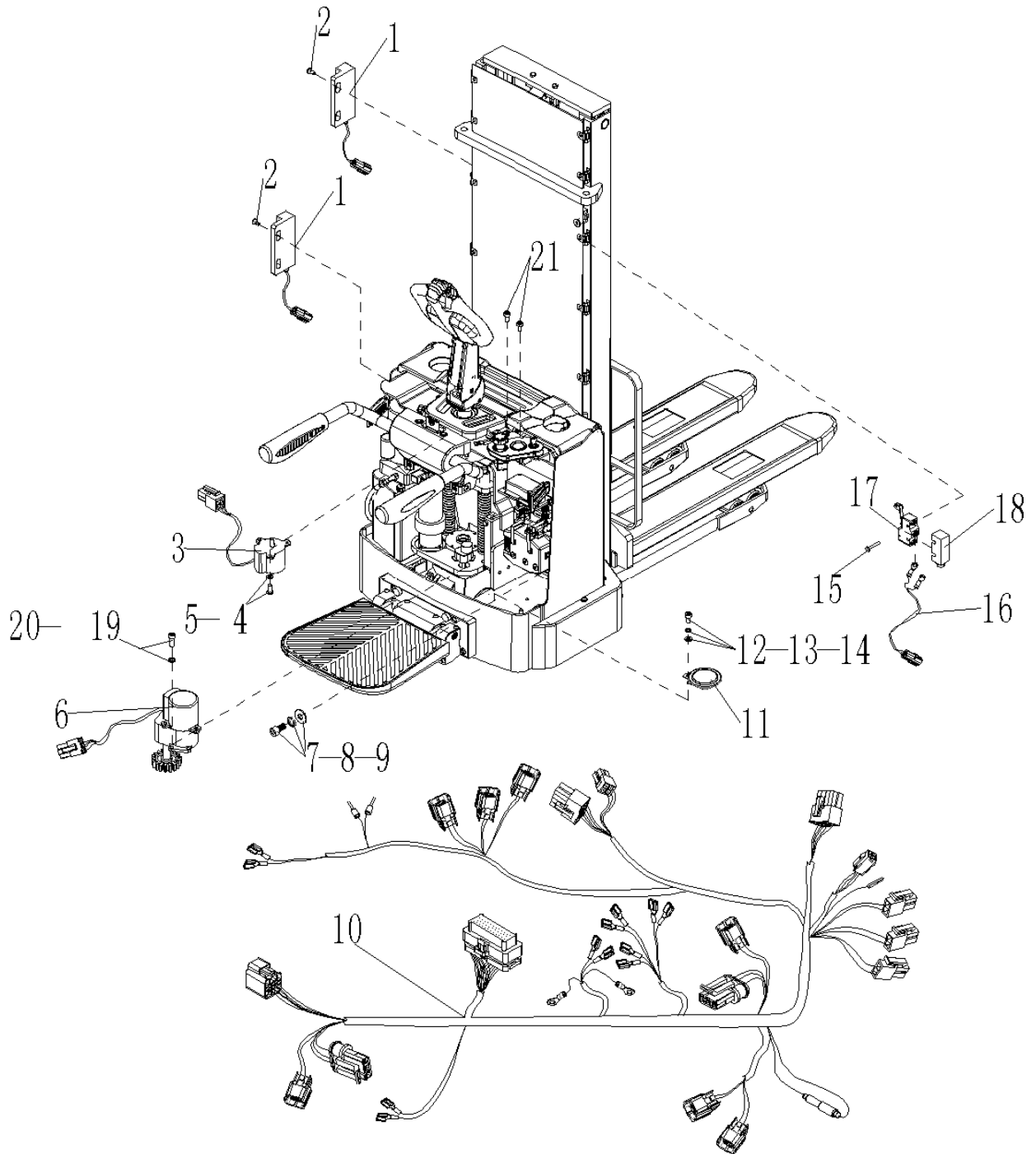

**Fig.18 Electric parts(electrical steering)**

No.	Art No.	Description	Qty.	Note	Standard
1	0000023083	Screw	4	M3x8	GB/T70.2=ISO7380
2	9000008332	Magnetic switch	2	HWK23	
3	9000000239	Tiller sensor	1	BD-MS	
	9000008448			BD-MS-3	
4	0000025026	Washer	3	3	GB/T97.1
5	0000023216	Screw	3	M3×8	GB/T70.1=ISO4762
6	9000007132	Positioning sensor	1	BD-PS	
	9000008450			BD-PS-3	
7	0000023044	Screw	4	M8×20	GB/T70.1=ISO4762
8	0000025001	Washer	4	8	GB/T93
9	0000025011	Washer	4	8	GB/T97.1
10	9000008427	Main control wiring diagram	1		
11	1000434015	Horn	1	DC24V	
12	0000023478	Screw	1	M6×12	GB/T70.1=ISO4762
13	0000025010	Washer	1	6	GB/T93
14	0000023055	Washer	1	6	GB/T97.1
15	0000023033	Screw	2	M4×25	GB/T70.1=ISO4762
16	9000008428	Limit control wiring harness			
17	2040634001	Micro switch	1	XZ-15GW22-B	
18	2040603002	Limit switch protective cover	1		
19	0000023041	Screw	4	M4×30	GB/T818=ISO7045
20	0000025019	Washer	4	4	GB/T97.1
21	0000023106	Screw	2	M6×30	GB/T70.1=ISO4762

Fig. 19 Power supply assembly

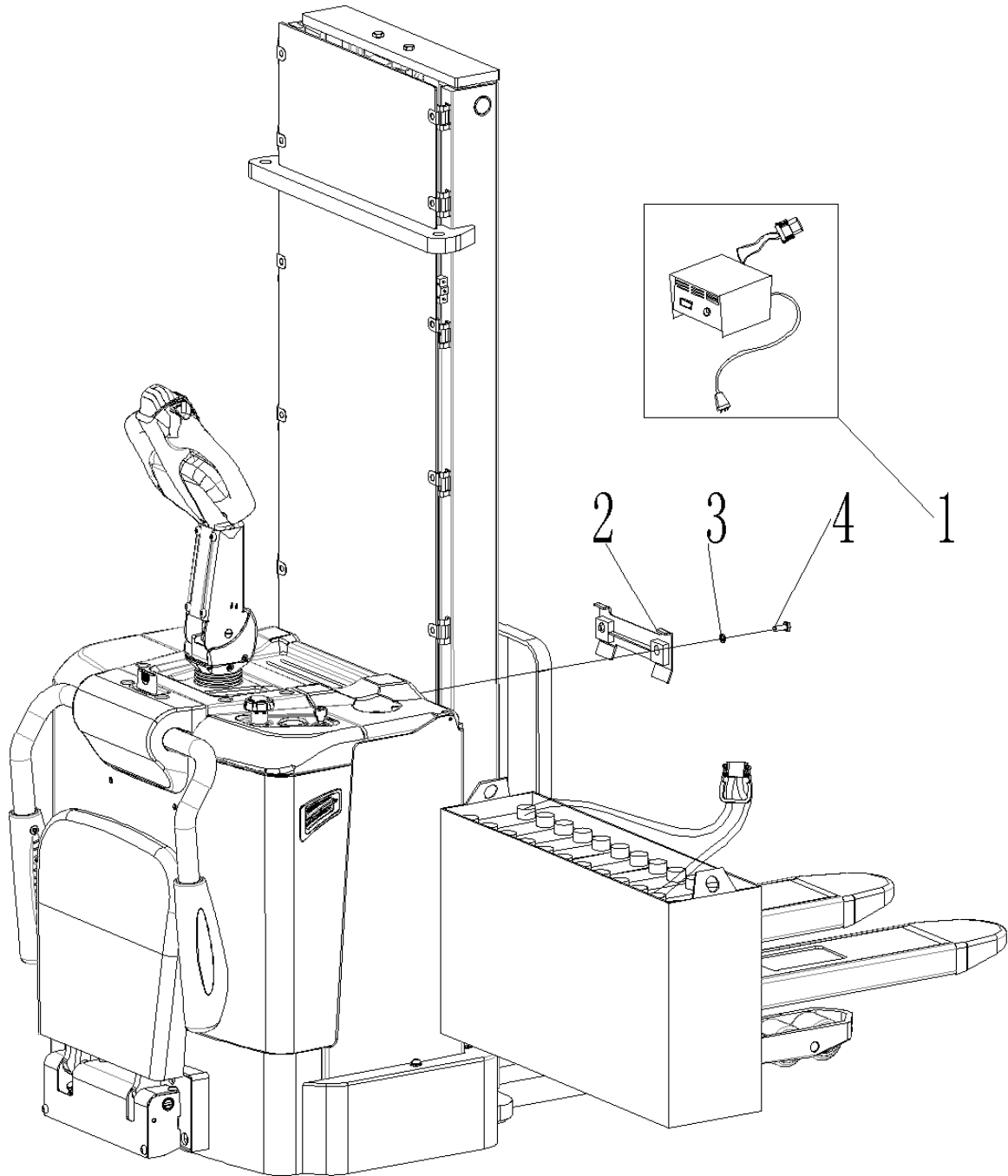

**Fig. 19 Power supply assembly**

No.	Art No.	Description	Qty.	Note	Standard
1	9000010116	Charger	1	Asia in Chinese	
	9000010117			Asia in English	
	9000010118			For EU	
	9000010120			For AUS	
	9000010121			For UK	
	9000010146			For USA	
2	9000008083	Welded battery limit	1		
3	0000025004	Washer	2	8	GB/T93
4	0000023250	Bolt	2	M8x30	GB/T5783



Fig. 20 Battery

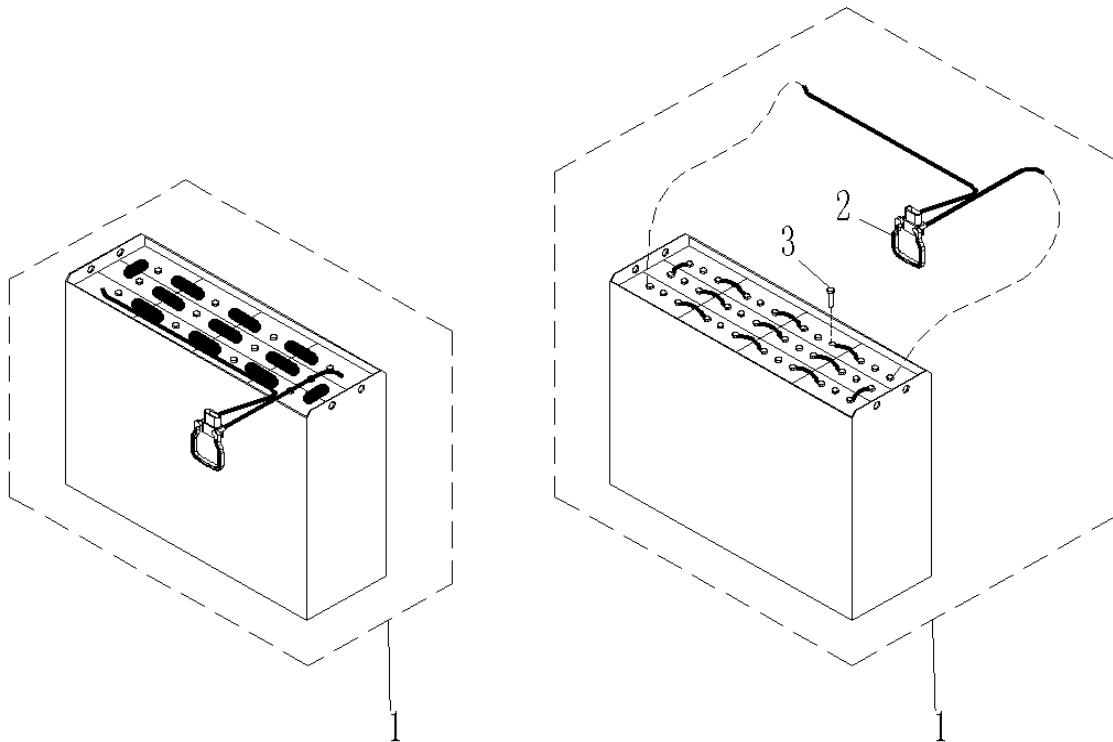

Fig.20 Battery

No.	Art No.	Description	Qty.	Note	Standard
1	9000008157	Battery	1	Weld type	
	9000009995			Bolt type	
2	9000009997	Plug	1		
3	9000009832	Screw	24	Only for bolt type battery	

Fig. 21 Hydraulic system(PS B12S One-stage mast)

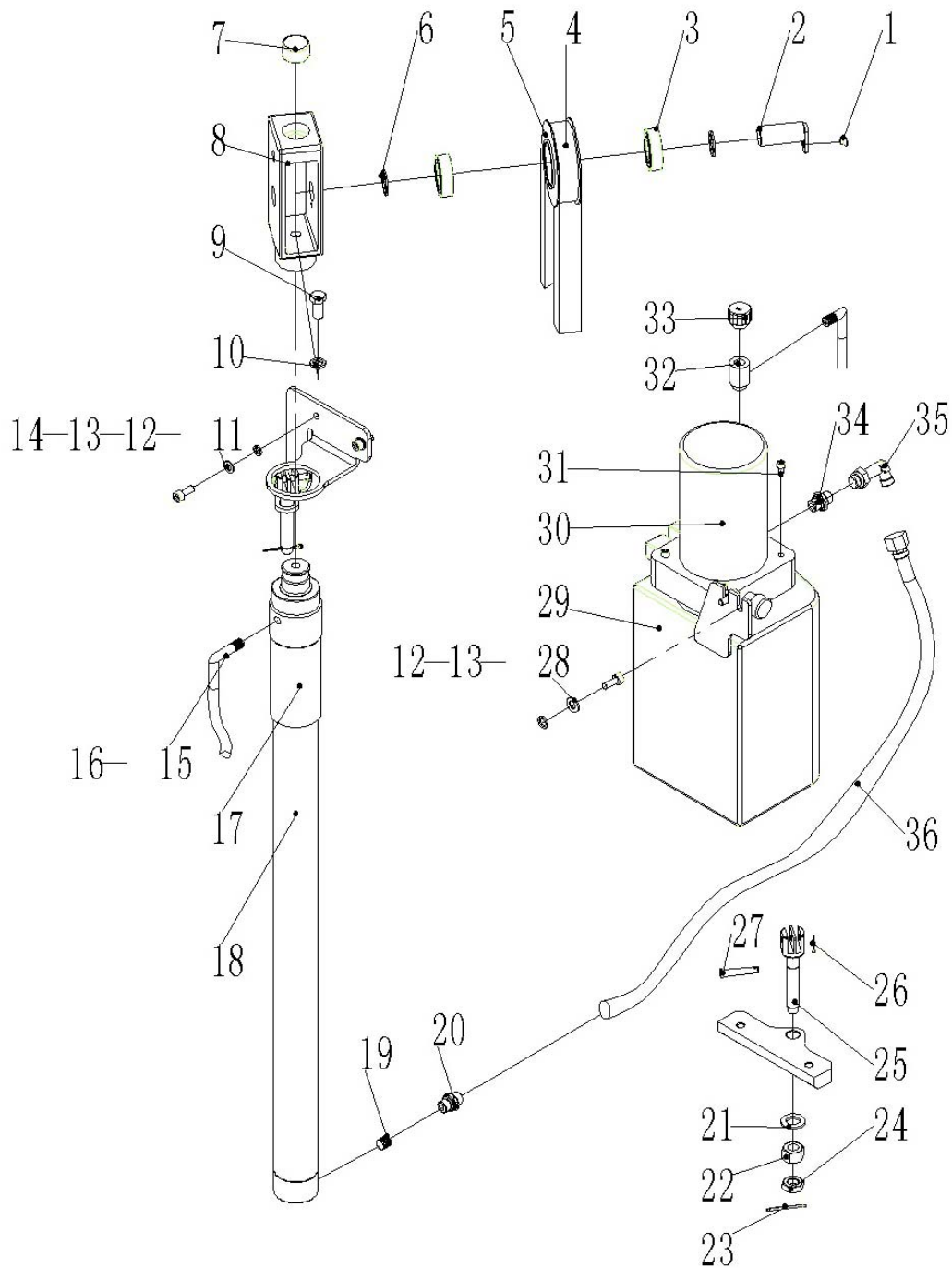
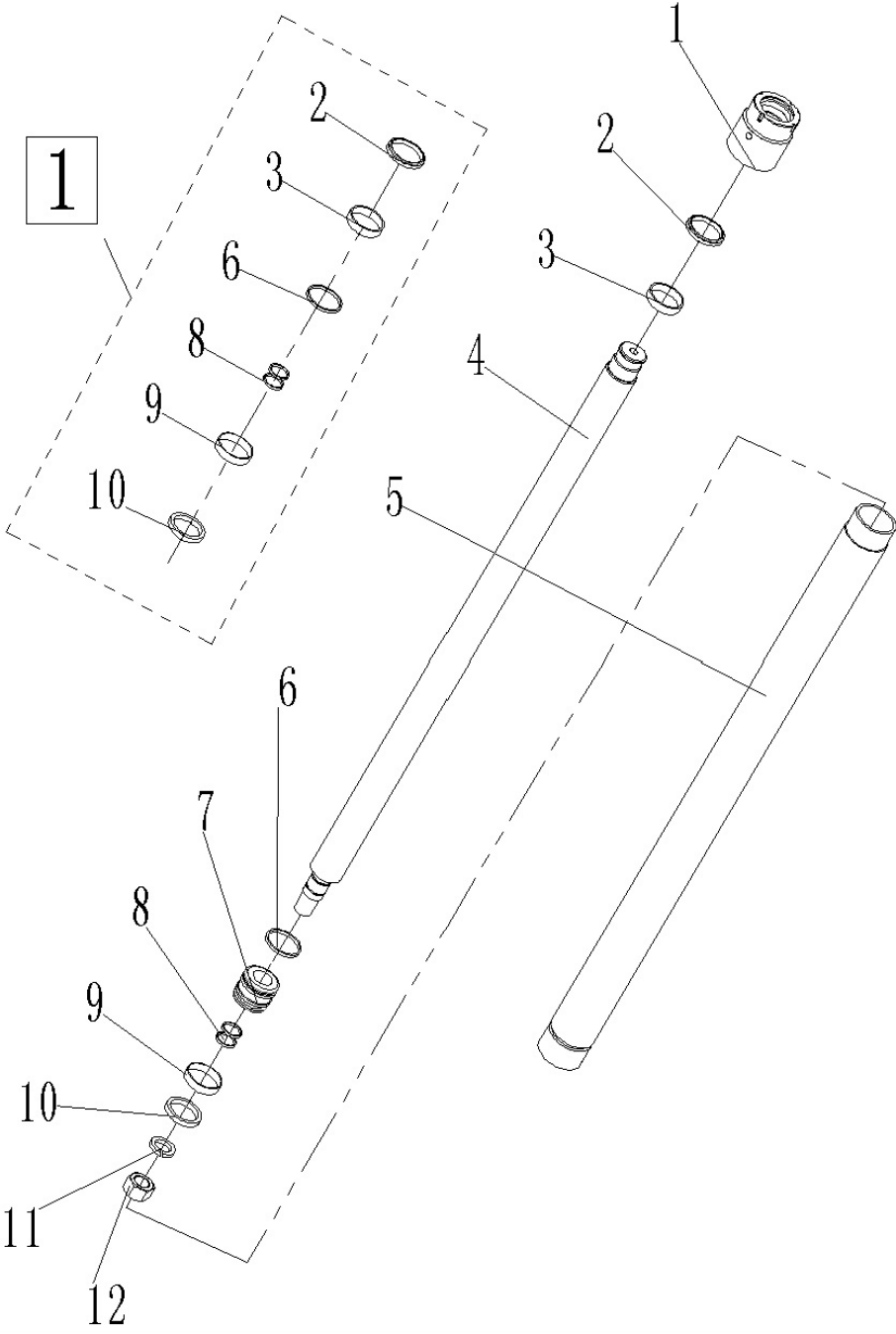

Fig. 21 Hydraulic system(PS B12S One-stage mast)

No.	Art No.	Description	Qty.	Note	Standard
1	0000023138	Screw	1	M6x10	GB/T70.3
2	2300301001	Pin axle fitting	1		
3	0000027011	Bearing	2	6205	GB/T276=ISO3290

4	0000029004	Chain LH1234	1	63	GB/T6074-2006
5	2000310001	Chain wheel for mast	1		
6	2240302001	Adjusting washer	2		
7	2010319001	Damping pad	1		
8	2310305002	Chain wheel frame	1		
9	0000023226	Bolt	1	M12x25	GB/T5783
10	0000025024	Washer	1	12	GB/T93
11	0000023147	Screw	2	M8x20	GB/T70.1=ISO4762
12	0000025004	Washer	4	8	GB/T93
13	0000025005	Washer	4	8	GB/T95
14	9000009356	Holder 1	1		
15	2010317001	Joint	2		
16	9000008140	Oil elbow	1		
17	2000301001	Pull rod seat	2		
18	9000009357	Cylinder	1	1600	
19	2000337001	Safety valve components	1		
20	9000007842	Straight joint	1		
21	0000025029	Washer	2	16	GB/T95
22	0000024042	Nut	2	M16x1.5	GB/T6171
23	0000028011	Split pin	2	3x40	GB/T91
24	0000024069	Nut	2	M16x1.5	GB/T6173=ISO8675
25	9000009087	Chain pulling bar	2		
26	0000028010	Split pin	2	2x20	GB/T91
27	9000009088	Chain pin shaft	2		
28	0000023146	Screw	2	M8x16	GB/T70.1=ISO4762
29	9000008141	Welded cylinder	1		
30	2000300001	DC power unit	1	24V2.2KW2.2	
31	0000023090	Screw	4	M6x35	GB/T70.1=ISO4762
32	2010317003	Joint	1		
33	2000303001	Cylinder cover	1		
34	9000007832	G straight joint	1		
35	9000007838	Steering connecting joint	1		
36	9000007259	Tube assembly	1		

Fig. 22 Cylinder(PS B12S One-stage mast)



**Fig. 22 Cylinder(PS B12S One-stage mast)**

No.	Art No.	Description	Qty.	Note	Standard
1	9000009358	Cylinder cover	1		
2	2000322001	Dust ring	1	40×48-5/6.5	
3	2000322002	Support ring for shaft	1	40×10-2	
4	9000009360	Lever	1		
5	9000009359	Cylinder barrel	1		
6	0000022013	O seal ring	1	45×3.1	GB1235
7	9000009361	Piston	1		
8	0000022014	O seal ring	2	25×3.1	GB1235
9	2000322003	Support ring for hole	1	45×10-2	
10	2010322001	Y seal ring	1	45×35-6	
11	0000025033	Washer	1	20	GB/T93
12	0000024074	Nut	1	M20×1.5	GB/T6171
☐	9000009953	Seal kit	1		

Fig. 23 Pump system

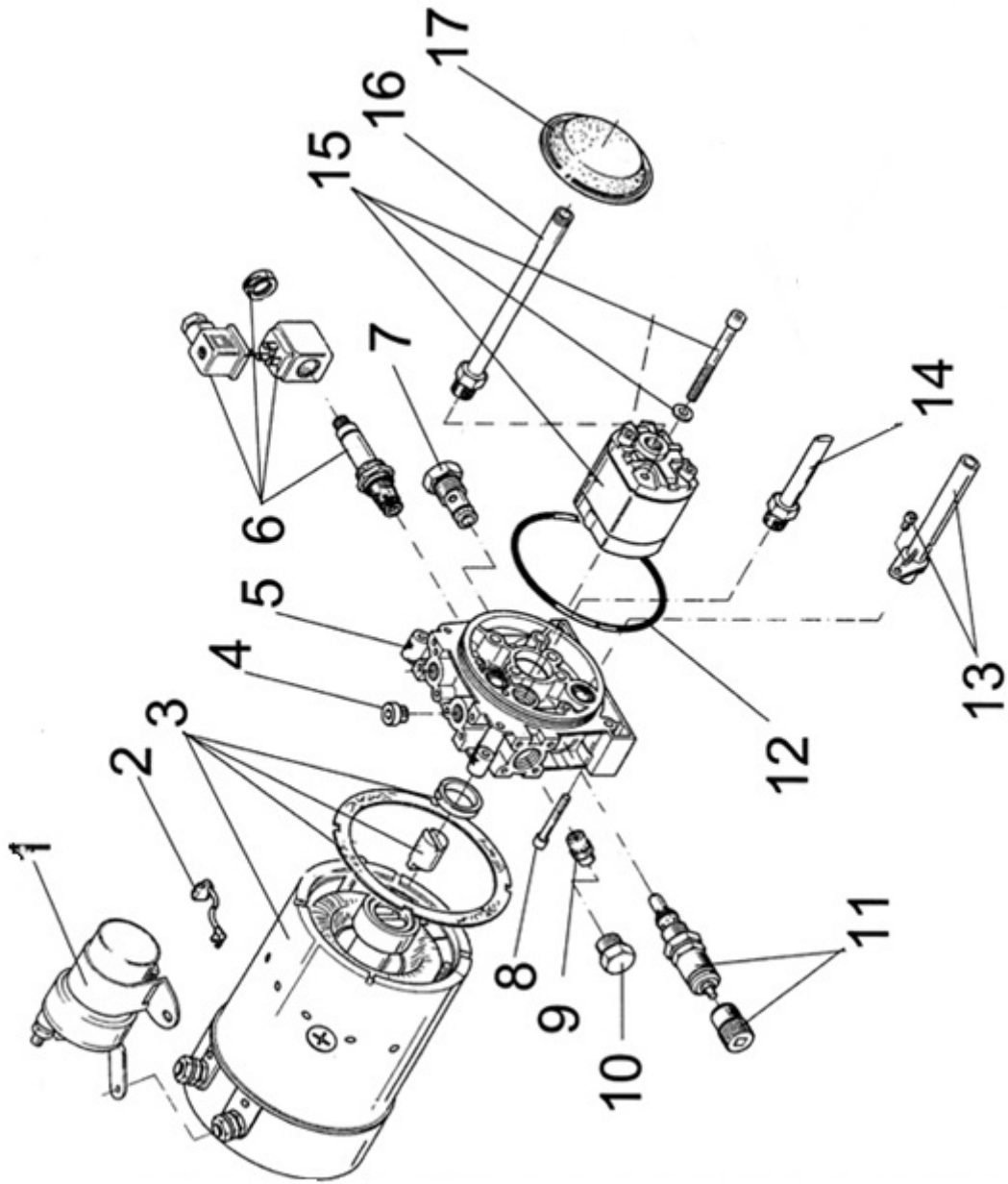

**Fig. 23 Pump system**

No.	Art No.	Description	Qty.	Note	Standard
1	2000335001	Pump contctor	1		
2	2000335002	Carbon brush (components)	1	Iskra	
3	2000334001	Motor	1	Iskra	
4	2000323001	Plug	1		
5	2000300002	Valve	1		
6	2000335003	Electromagnetic valve	1		
7	2000335004	Check valve	1		
8	2000323002	Screw	4		
9	2000335005	Flow control valve	1		
10	2000323003	Plug	1		
11	2000335006	Overflow valve	1		
12	2000322004	O ring	1		
13	2000317008	Oil elbow	1		
14	2000317009	Oil elbow	1		
15	2000300003	Gear pump	1		
16	2000317010	Oil suction pipe	1		
17	2000300004	Filter	1		

Fig. 24 Hydraulic system(PS B12D Two-stage mast Lift)

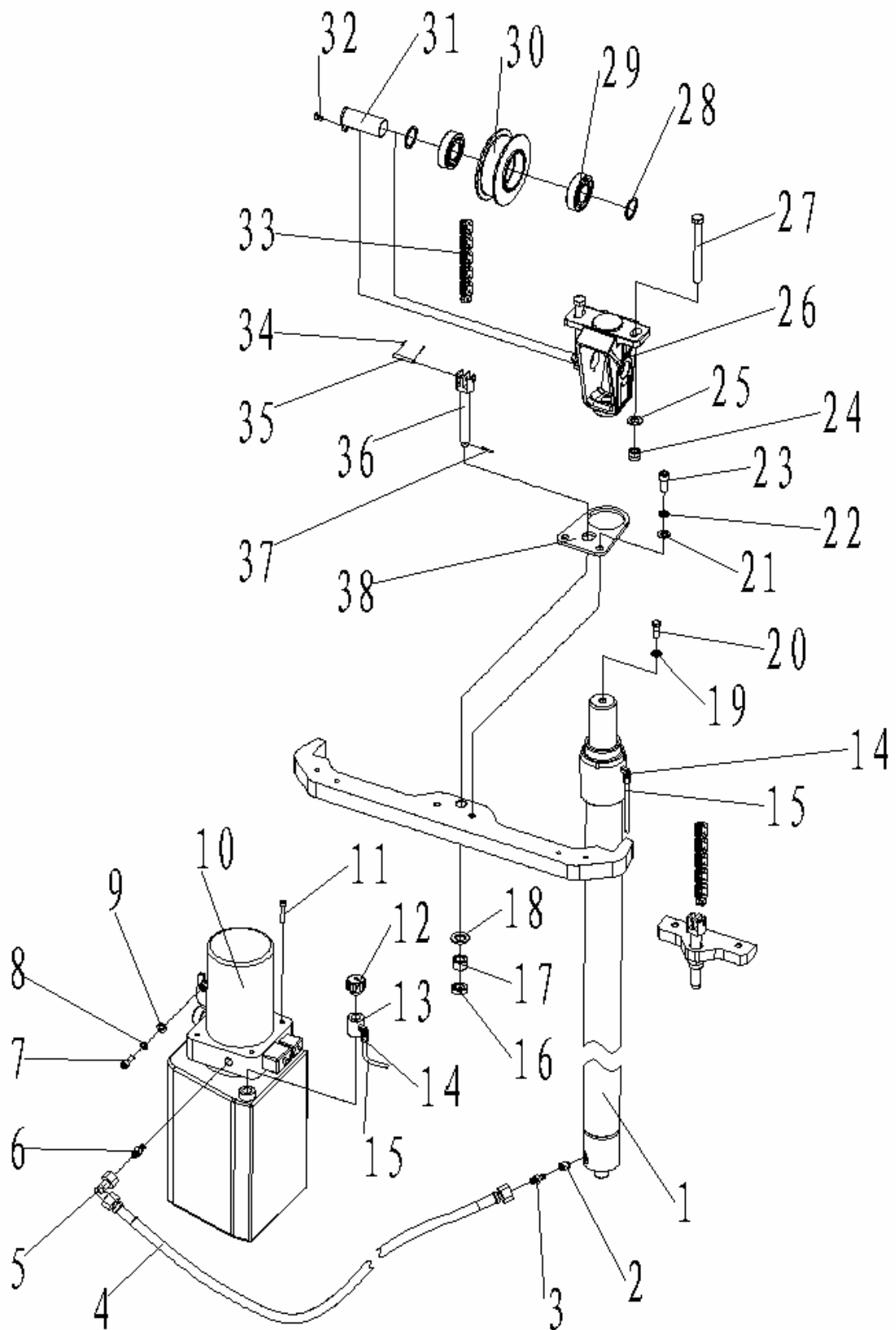



**Fig. 24 Hydraulic system(PS B12D Two-stage mast Lift)**

No.	Art No.	Description	Qty.	Note	Standard
1	9000008115	Cylinder components	1	3200	
	9000008124			2900	
	9000009135			3600	
	9000009139			2600	
2	2000337001	Safety valve components	1		
3	9000007842	Straight joint	1		
4	9000007259	Tube	1		
5	9000007838	Steering connecting joint	1		
6	9000007832	G straight joint	1		
7	0000023067	Screw	2	M8x16	GB/T70.1=ISO4762
8	0000025001	Washer	2	8	GB/T93
9	0000025011	Washer	2	8	GB/T95
10	2000300001	DC power unit	1	24V2.2KW 2.2	
11	0000023090	Screw	4	M6×35	GB/T70.1=ISO4762
12	2000303001	Vent plug	1		
13	2010317003	Joint	1		
14	2010317001	90° oil joint	2		
15	9000008140	Oil elbow	1		
16	0000024014	Nut	2	M16×1.5	GB/T6173 =ISO8675
17	0090000442	Nut	2	M16×1.5	GB/T6171
18	0000025029	Washer	2	16	GB/T95
19	0000025024	Washer	1	12	GB/T93
20	0000023094	Screw	1	M12×30	GB/T70.1=ISO4762
21	0090000047	Washer	2	10	GB/T97.1
22	0000023006	Washer	2	10	GB/T93
23	0000023088	Screw	2	M10×25	GB/T70.1=ISO4762
24	0000024006	Nut	2	M12	GB/T889.1=ISO7040
25	0000025032	Washer	2	12	GB/T95
26	2220305001	Chain wheel frame	1		
27	0000023209	Bolt	2	M12×130	GB/T5780

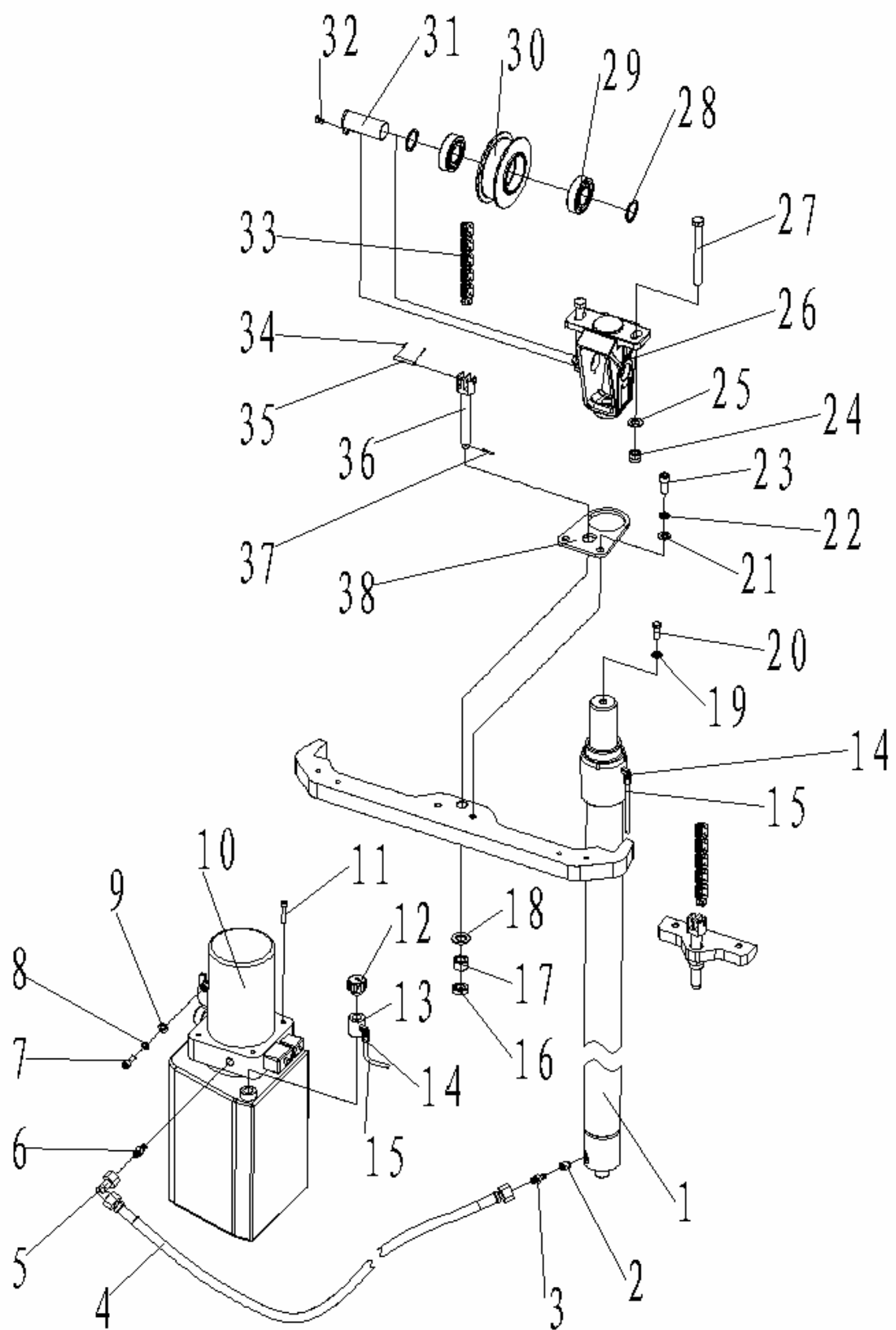

**Fig. 24 Hydraulic system(PS B12D Two-stage mast Lift)**

28	9000008118	Adjusting washer	2		
29	0000027012	Bearing	2	6206	GB/T276=ISO3290
30	9000008117	Chain wheel	1		
31	9000008116	Chain wheel axle components	1		
32	0000023091	Screw	1	M6×12	GB/T70.3
33	0000029316	Chain	1	3200	GB/T6074
	0000029035			2900	GB/T6074
	0090000489			3600	GB/T6074
	0090000490			2600	GB/T6074
34	0000028111	Split pin	4	1.6×10	GB/T91
35	0000028110	Pin shaft	2	6×40	GB/T880
36	9000008114	Chain pulling bar	2		
37	0000028011	Split pin	2	3×40	GB/T91
38	9000008113	Fixing plate	1		

Fig. 25 Cylinder(PS B12D Two-stage mast Lift)

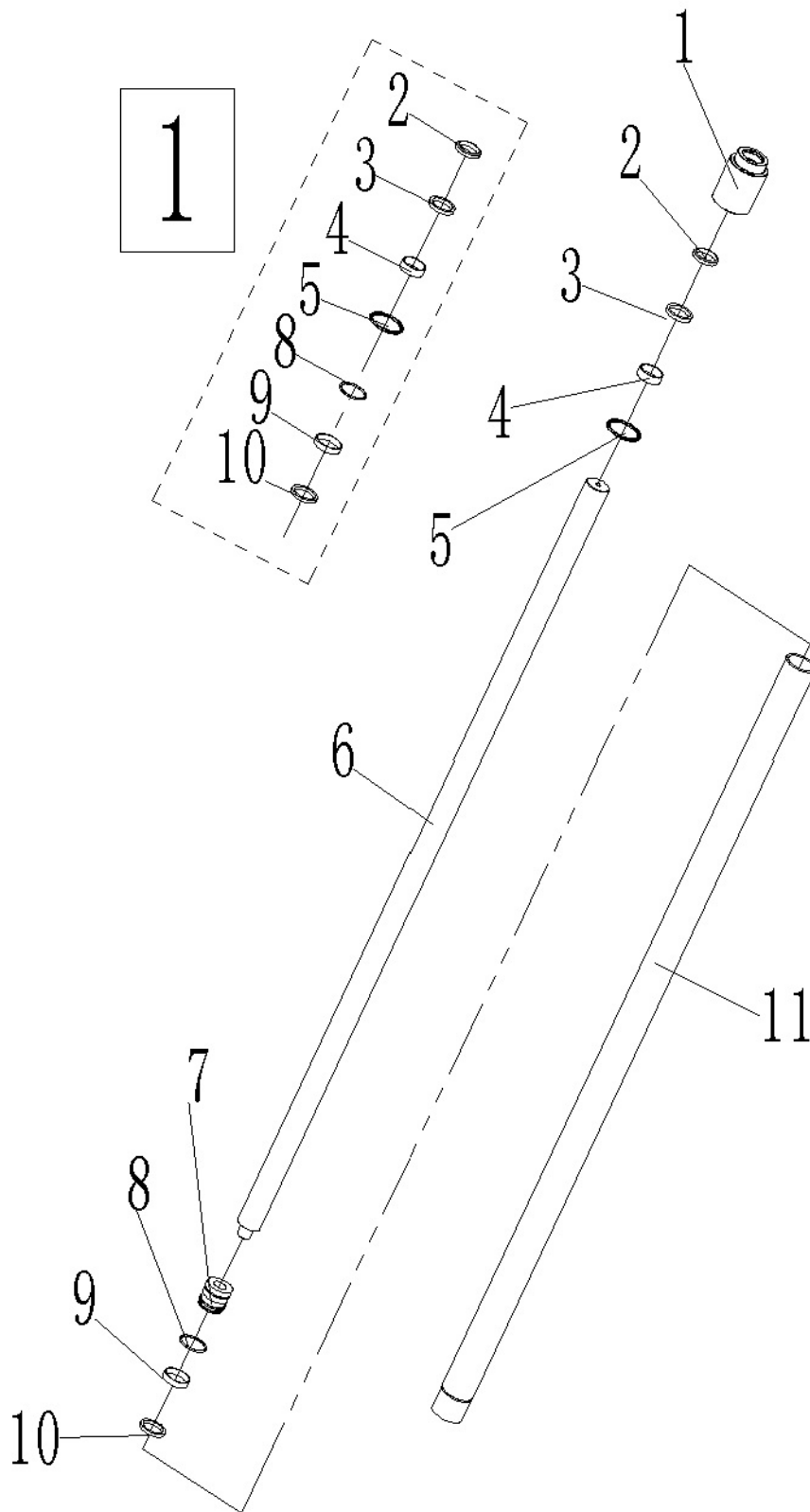

**Fig. 25 Cylinder(PS B12D Two-stage mast Lift)**

No.	Art No.	Description	Qty.	Note	Standard
1	9000009168	End cap	1		
2	9000009169	Dust ring	1	40×48×5/6.5	
3	9000009170	Y ring for shaft	1	40×50×6/7	
4	9000009171	Support ring for shaft	1	40×44×10	
5	0090000491	O ring	1	56X2.4	GB12
6	9000009172	Piston rod	1	3200	
	9000009173			2900	
	9000009174			3600	
	9000009175			2600	
7	9000009176	Piston	1		
8	0000022029	O ring	1	Φ50×3.1	GB1235
9	9000009177	Support ring for hole	1	46×50×10	
10	9000009178	Y ring for hole	1	40×50×6/7	
11	9000009187	Cylinder body	1	3200	
	9000009188			2900	
	9000009189			3600	
	9000009190			2600	
①	9000009954	Seal kit	1		

Fig. 26 Hydraulic system(PS B12F Two-stage mast Full-Free-Lift)

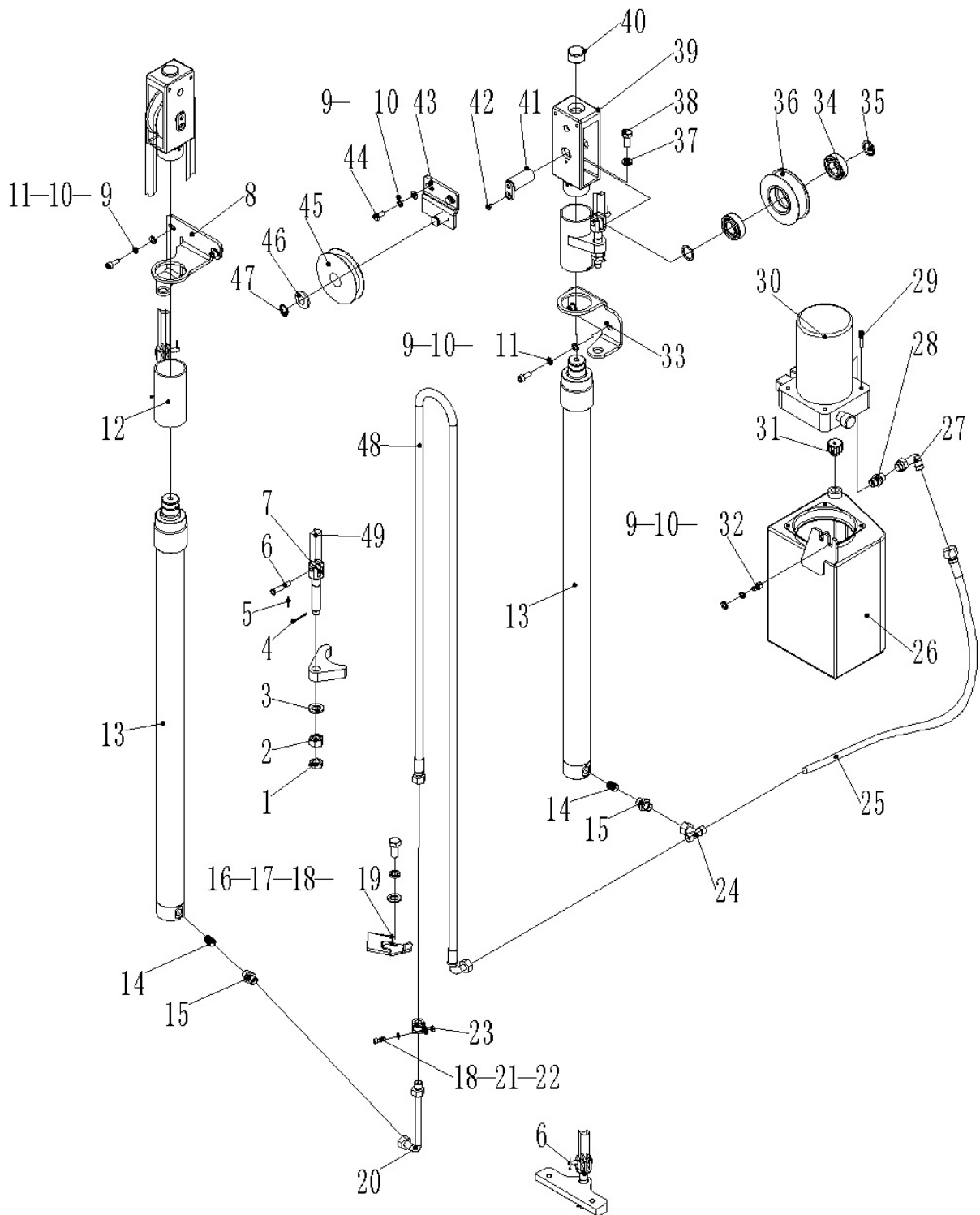

**Fig. 26 Hydraulic System(PS B12F Two-stage mast Full-Free-Lift)**

No.	Art No.	Description	Qty.	Note	Standard
1	0000024010	Nut	4	M16	GB/T6172.1
2	0000024184	Nut	4	M16	GB/T6170
3	0000025029	Washer	4	16	GB/T95
4	0000028011	Split pin	4	3×40	GB/T91
5	0000028010	Split pin	4	2×20	GB/T91
6	9000009088	Chain pin shaft	4		
7	9000009087	Chain pulling rod	4		
8	9000009003	Cylinder fixing plate	1		
9	0000025005	Washer	4	8	GB/T95
10	0000025004	Washer	4	8	GB/T93
11	0000023146	Screw	4	M8V16	GB/T70.1=ISO4762
12	2000301001	Pulling rod block	2		
13	9000009086	Cylinder components	2	3200	
	9000009094			2900	
14	2000337001	Safety valve components	2		
15	9000007842	Straight joint	2		
16	2000302005	Tube board	1		
17	0000023845	Screw	2	M6×10	GB/T70.1=ISO4762
18	0000025006	Washer	1	6	GB/T93
19	0000025007	Washer	2	6	GB/T95
20	9000009004	Steel pipe	1		
21	0000023040	Screw	1	M6×16	GB/T70.1=ISO4762
22	0000024061	Nut	1	M6	GB/T6172.1
23	9000008325	YGE hose clamp	1		
24	9000008887	Steering connecting joint	1		
25	9000007259	Tube	1		
26	9000008141	Cylinder	1		
27	9000007838	Steering connecting joint	1		
28	9000007832	G straight joint	1		
29	0000023090	Screw	4	M6×35	GB/T70.1=ISO4762
30	2000300001	DC power unit	1		
31	2000303001	Vent plug	1		

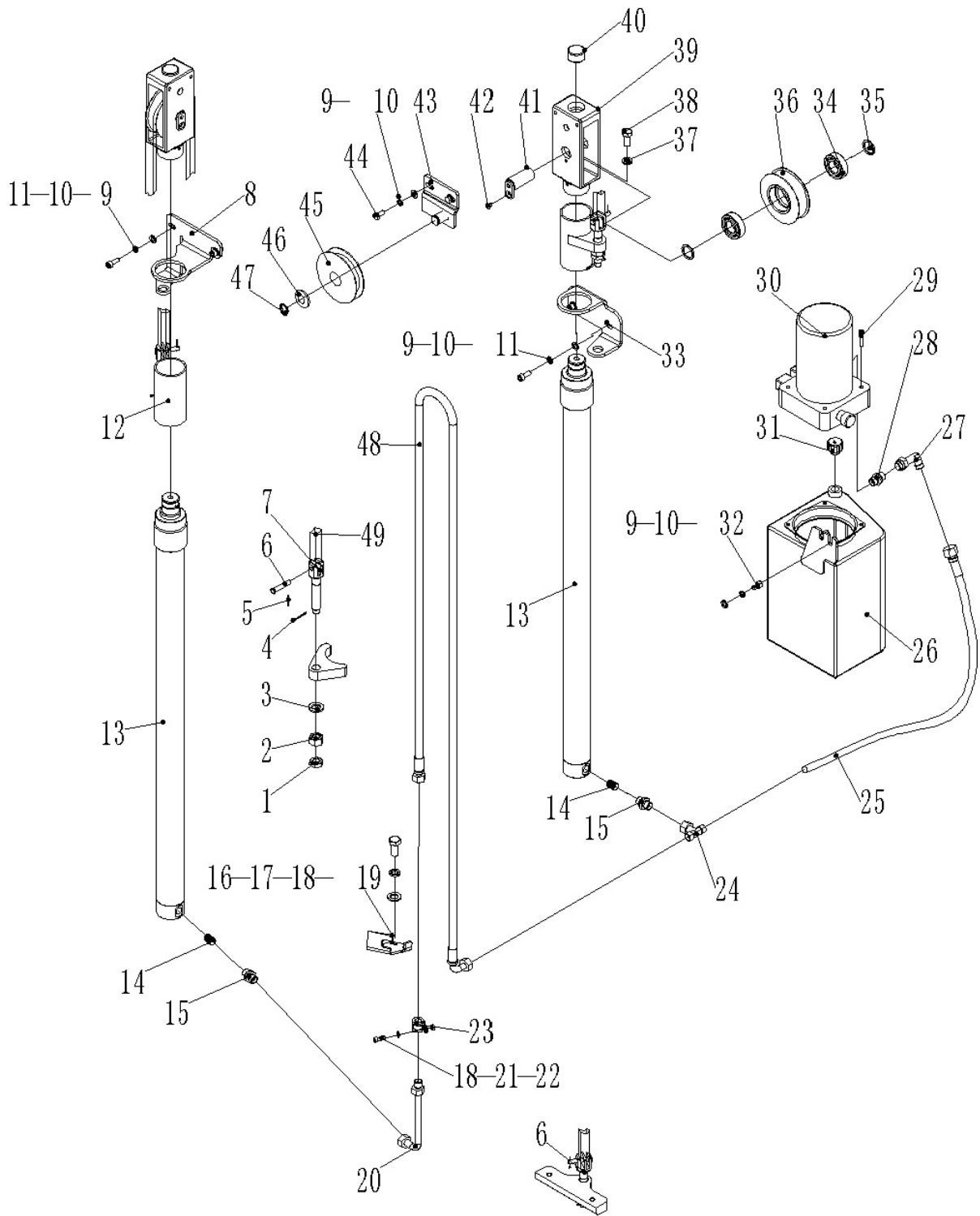
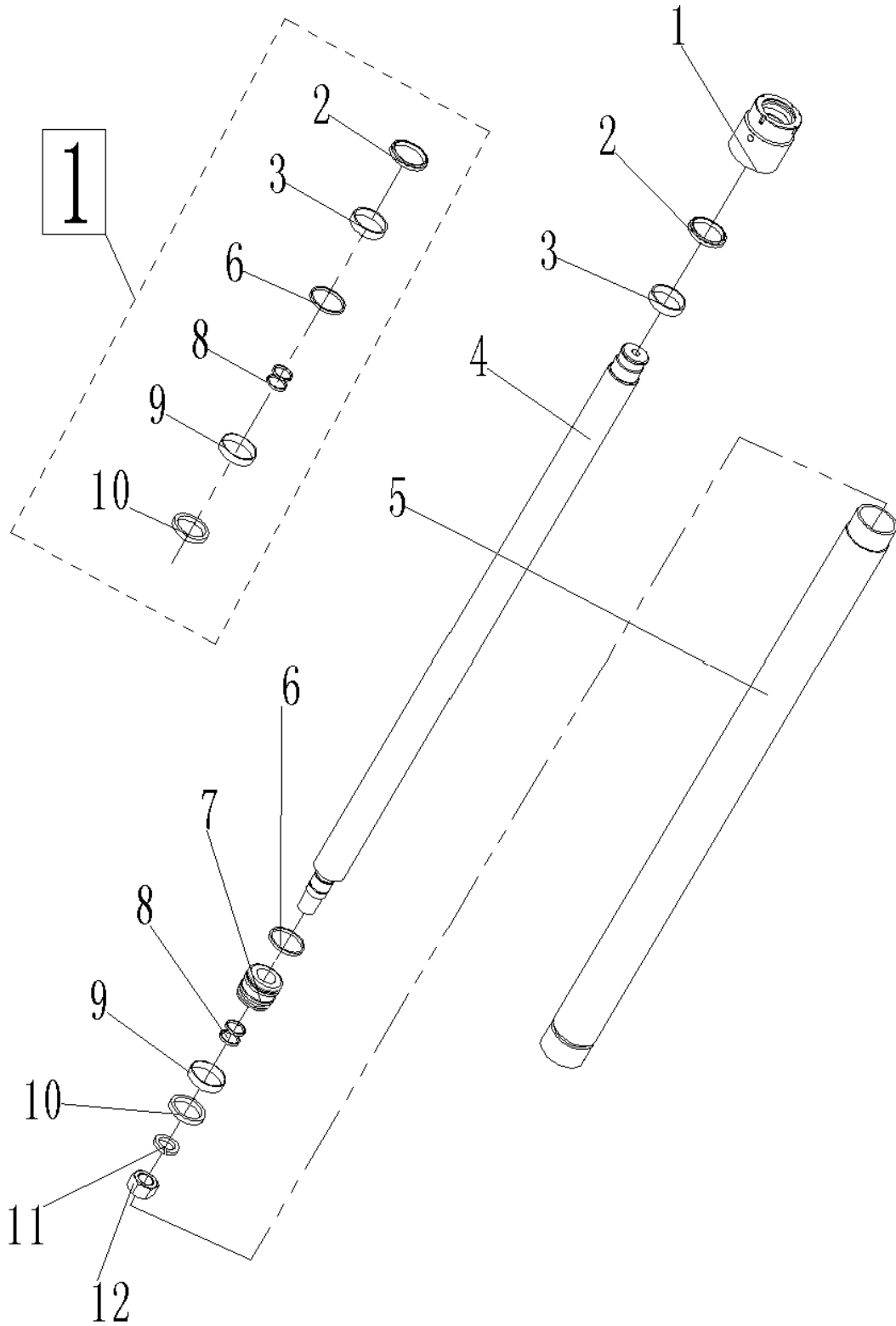



**Fig. 26 Hydraulic System(PS B12F Two-stage mast Full-Free-Lift)**

32	0000023089	Screw	2	M8×12	GB/T70.1=ISO4762
33	9000009003	Frame	1		
34	0000027011	Bearing	4	6025	GB/T276=ISO3290
35	2240302001	Adjusting washer	4		
36	2000310001	Chain wheel	2		
37	0000025024	Washer	2	12	GB/T93
38	0000023226	Bolt	2	M12×25	GB/T5783
39	2310305002	Chain frame	2		
40	2010319001	Damping pad	2		
41	2300301001	Pin shaft fitting	2		
42	0000023557	Screw	2	M6×10	GB/T70.3
43	2000301002	Welded pulley frame	1		
44	0000023230	Bolt	2	M8×16	GB/T5783
45	2000310002	Pulley	1		
46	0000025092	Washer	1	20	GB/T97.2
47	0000026003	circlip	1	20	GB/T894.1
48	9000008886	Tube	1	3200	
	9000008888			2900	
49	0000029204	Chain LH1234×67	2	3200	GB/T6074
	0000029004	Chain LH1234×63	2	2900	GB/T6074

Fig. 27 Cylinder(PS B12F Two-stage mast Full-Free-Lift)



**Fig. 27 Cylinder(PS B12F Two-stage mast Full- Free-Lift)**

No.	Art No.	Description	Qty.	Note	Standard
1	9000009191	Cylinder cap	1		
2	2000322001	Dust ring	1	40×48-5/6.5	
3	2000322002	Support ring for shaft	1	40×10-2	
4	9000009192	Lever	1	3200	
	9000010359			2900	
5	9000009193	Cylinder barrel	1	3200	
	9000010360			2900	
6	0000022013	O seal ring	1	45×3.1	GB1235
7	9000009194	Piston	1		
8	0000022014	O seal ring	2	25×3.1	GB1235
9	2000322003	Support ring for hole	1	45×10-2	
10	2010322001	Y seal ring	1	45×35-6	
11	0000025033	Washer	1	20	GB/T93
12	0000024074	Nut	1	M20×1.5	GB/T6171
□	9000009955	Seal kit	1		

Fig. 28 Drive system(manual steering)

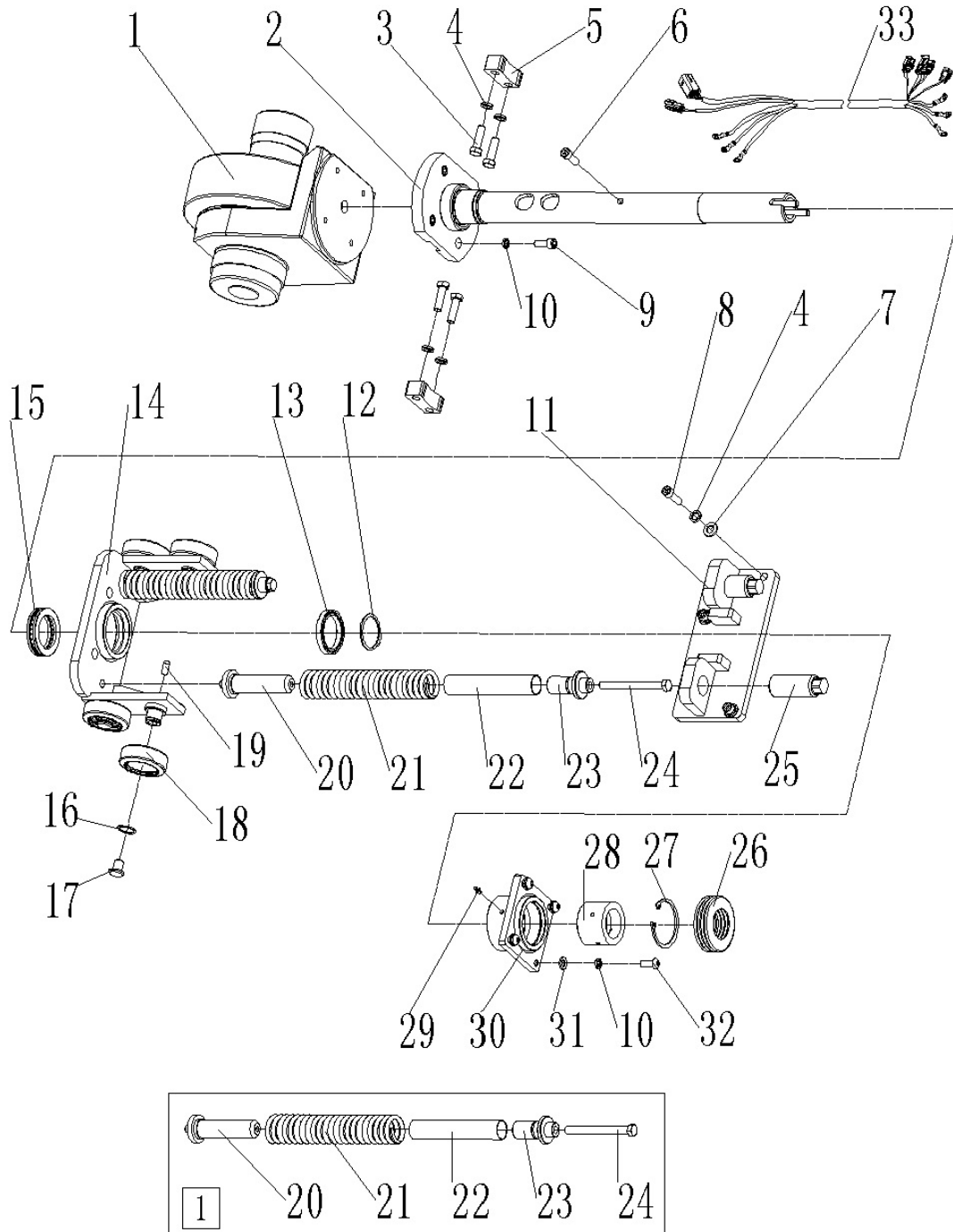
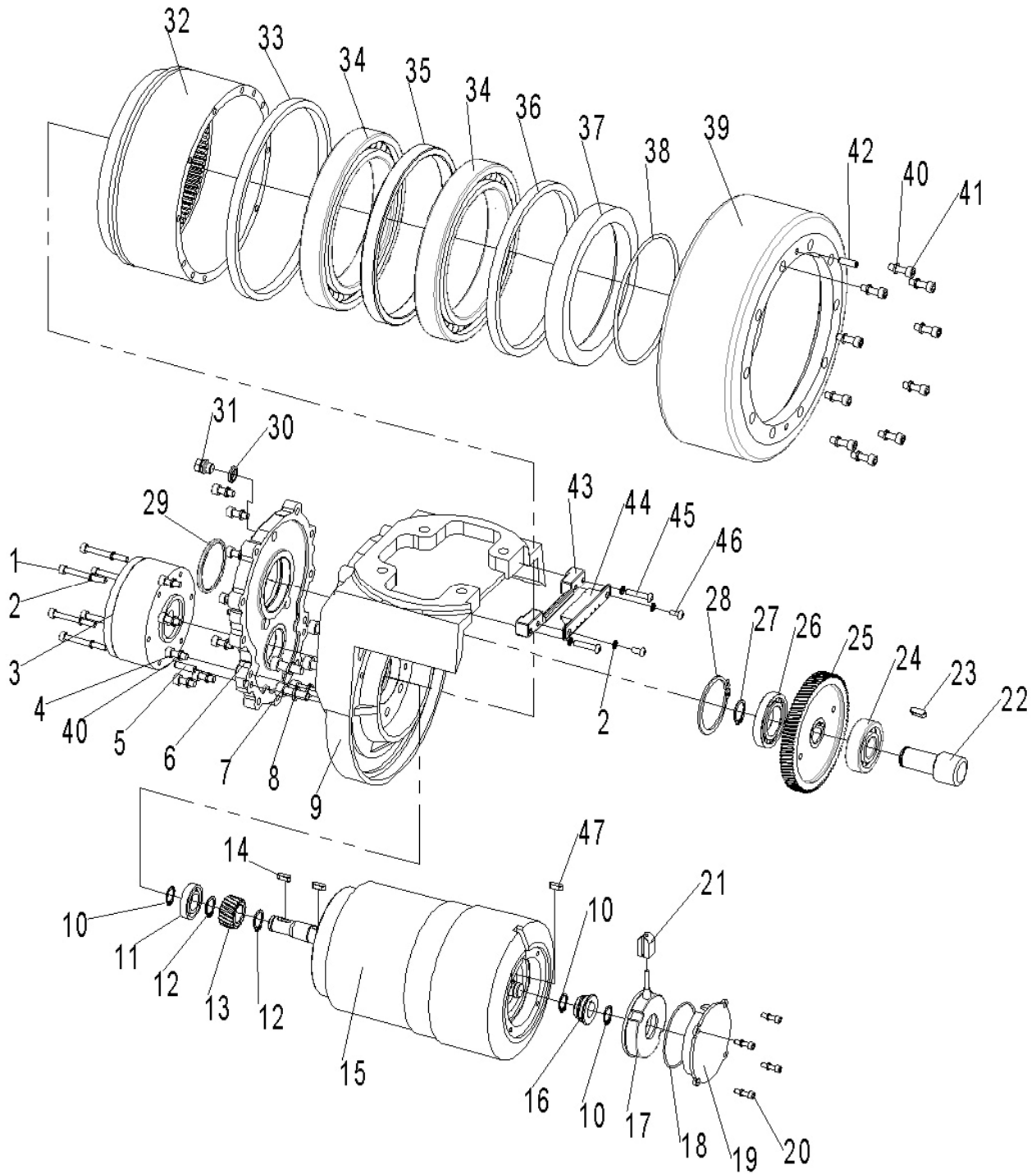

Fig.28 Drive system(manual steering)

No.	Art No.	Description	Qty.	Note	Standard
1	9000007773	Drive wheel	1	∅252	
2	9000008142	Welded long axle	1		

3	0000023184	Bolt	4	M12×40	GB/T5783
4	0000025024	Washer	8	12	GB/T93
5	9000008134	Limit block	2		
6	0000023158	Bolt	1	M10×30	GB/T70.1=ISO4762
7	0000025032	Washer	4	12	GB/T95
8	0000023082	Bolt	4	M12×35	GB/T70.1=ISO4762
9	0000023088	Bolt	4	M10×25	GB/T70.1=ISO4762
10	0000023006	Washer	8	10	GB/T93
11	9000008145	Welded fixing frame	1		
12	0000026015	Circlip	1	∅55	GB/T894.1
13	0090000456	Bearing	1	61811-Z	GB/T276=ISO3290
14	9000008149	Welded wheel frame	1		
15	0000027085	Bearing	1	51111	GB/T301
16	0000026013	Circlip	4	∅25	GB/T894.1
17	9000008152	Adjusting block	4		
18	9000008153	Roller	4		
19	0090000457	Screw	4	M12×20	GB/T77
20	9000008147	Spring guide rod	2		
21	2000231002	Spring	2	∅7×∅40× 342	
22	2000208001	Spring guide bushing	2		
23	9000008148	Spring pressing cover	2		
24	2000223001	Bolt	2	M10×180	
25	9000008144	Adjusting stud	2		
26	9000008143	Dust cover	1		
27	0000026020	Circlip	1	∅70	GB/T893.1
28	9000008151	Nylon guide sleeve	1		
29	0000030002	Oil cup	1	M6	JB/T7940.1
30	9000008150	Welded guide sleeve	1		
31	0000025002	Washer	4	10	GB/T95
32	0000023038	Bolt	4	M10×25	GB/T5783
33	9000008405	Drive motor wiring harness	1		
①	9000008146	Spring components	2		

Fig. 29 Drive wheel(43EL)



**Fig.29 Drive wheel(43EL)**

No.	Art No.	Description	Qty.	Note	Standard
1	0090000101	Screw	6	M5×45	GB/T70.1=ISO4762
2	0000025012	Washer	10	5	GB/T93
3	9000008846	Brake	1		
4	0000023040	Screw	11	M6×16	GB/T70.1=ISO4762
5	0000028175	Dowel pin	2	6×22	GB/T120.2
6	9000008847	Gear box cover	1		
7	0000023047	Screw	5	M8×25	GB/T70.1=ISO4762
8	0000025012	Washer	5	8	GB/T93
9	9000008848	Gear box	1		
10	0000026004	Circlip	3	15	GB894.1
11	0000022232	Oil seal	1	17×35×7	GB/T9877
12	0000026005	Circlip	2	17	GB/T894.1
13	9000008849	Small gear	1		
14	0000036002	Flat key	2	A5×14	GB/T1096
15	9000008850	AC motor	1		
16	9000008851	Shaft sleeve	1		
17	9000008852	Sensor	1		
18	0000022002	O seal ring	1	6.3×1.8	GB/T3452.1
19	9000008853	Protective cover	1		
20	0090000473	Screw	4	M4×10	GB/T70.3
21	9000008854	Bushing	1		
22	9000008855	Gear shaft	1		
23	0000036001	Flat key	1	A6×16	GB/T1096
24	0000027067	Bearing	1	6304	GB/T276=ISO3290
25	9000008856	Big gear	1		
26	0090000285	Bearing	1	6006	GB/T276=ISO3290
27	0000026003	Circlip	1	20	GB/T894.1
28	0000026007	Circlip	1	55	GB/T893.1

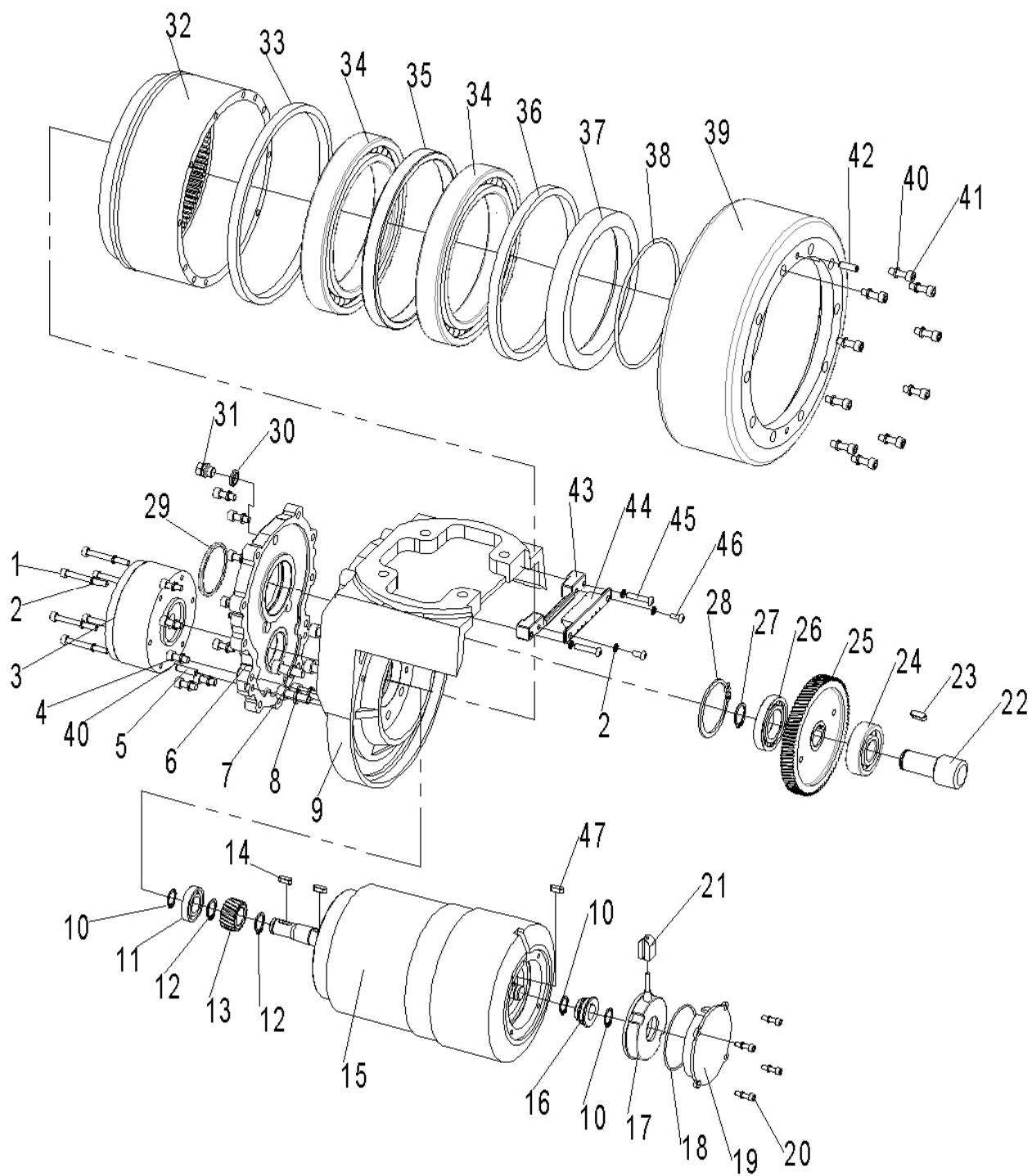
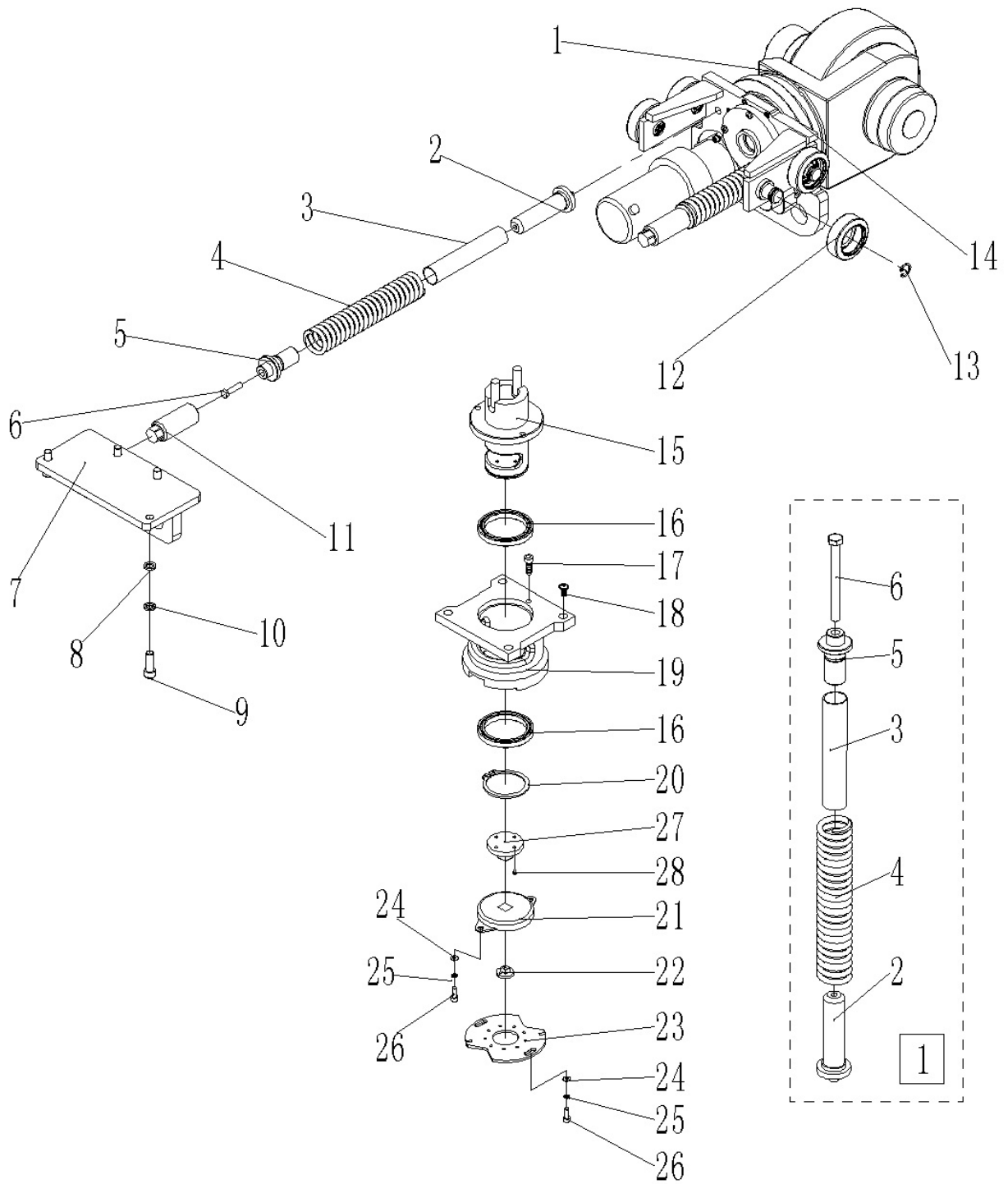



**Fig.29 Drive wheel(43EL)**

29	9000008857	Cover	1		
30	0000025021	Washer	1	10	JB/T982
31	2000303001	Vent plug	1	10	
32	9000008858	Internal gear	1		
33	0000022007	Oil seal	1	188×202×10	GB/T9877
34	0090000453	Bearing	2	61926-2LS	GB/T276=ISO3290
35	9000008859	Bushing	1		
36	0090000178	Oil seal	1	160×175×10	GB/T9877
37	9000008860	Oil seal seat	1		
38	0090000454	O ring	1	125×3.55	GB/T3452.1
39	9000008861	Drive wheel	1		
40	0000025006	Washer	21	6	GB/T93
41	0000023062	Screw	10	M6×20	GB/T70.1=ISO4762
42	0000028177	Dowel pin	2	6×20	GB/T119.1
43	9000008862	Down wire holder	1		
44	9000008863	Upper wire holder	1		
45	0000023065	Screw	2	M5×25	GB/T70.2=ISO7380
46	0090000041	Screw	2	M5×10	GB/T70.2=ISO7380
47	0090000475	Flat key	1	A 5×10	GB/T1096

Fig. 30 Drive system(electrical steering)



**Fig.30 Drive system(electrical steering)**

No.	Art No.	Description	Qty.	Note	Standard
1	9000007777	Drive wheel	1	∅252	
2	9000008147	Spring guide rod	2		
3	2000208001	Spring guide bushing	2		
4	2000231002	Spring	2		
5	9000008148	Spring pressing cover	2		
6	2000223001	Bolt	2	M8×35	
7	9000008145	Welded fixing frame	1		
8	0000025032	Washer	4	12	GB/T95
9	0000023471	Screw	4	M12×35	GB/T70.1=ISO4762
10	0000025024	Washer	4	12	GB/T93
11	9000008144	Adjusting stud	2		
12	9000008153	Roller	4		
13	0000026013	Circlip	4	25	GB/T894.1
14	9000009195	Welded wheel frame	1		
15	9000007422	Welded axle seat	1		
16	9000000240	Bearing 61810	2	65×50×7	GB/T276=ISO3290
17	0000023042	Screw	3	M6×10	GB/T70.1=ISO4762
18	0000023034	Screw	4	M10×20	GB/T70.1=ISO4762
19	9000007423	Welded fixing seat	1		
20	0000026043	Circlip	1	50	GB/T894.1
21	9000007806	Damper	1		
22	9000007421	Linking block	1		
23	9000007693	Potentiometer fixing plate	1		
24	0000023032	Washer	4	5	GB/T95
25	0000025022	Washer	4	5	GB/T93
26	0000023311	Screw	4	M5×10	GB/T70.1=ISO4762
27	9000007424	Nylon block	1		
28	0000023073	Screw	4	M4×10	GB/T70.1=ISO4762
①	9000008146	Spring components	2		

Fig. 31 Drive wheel(23EL)

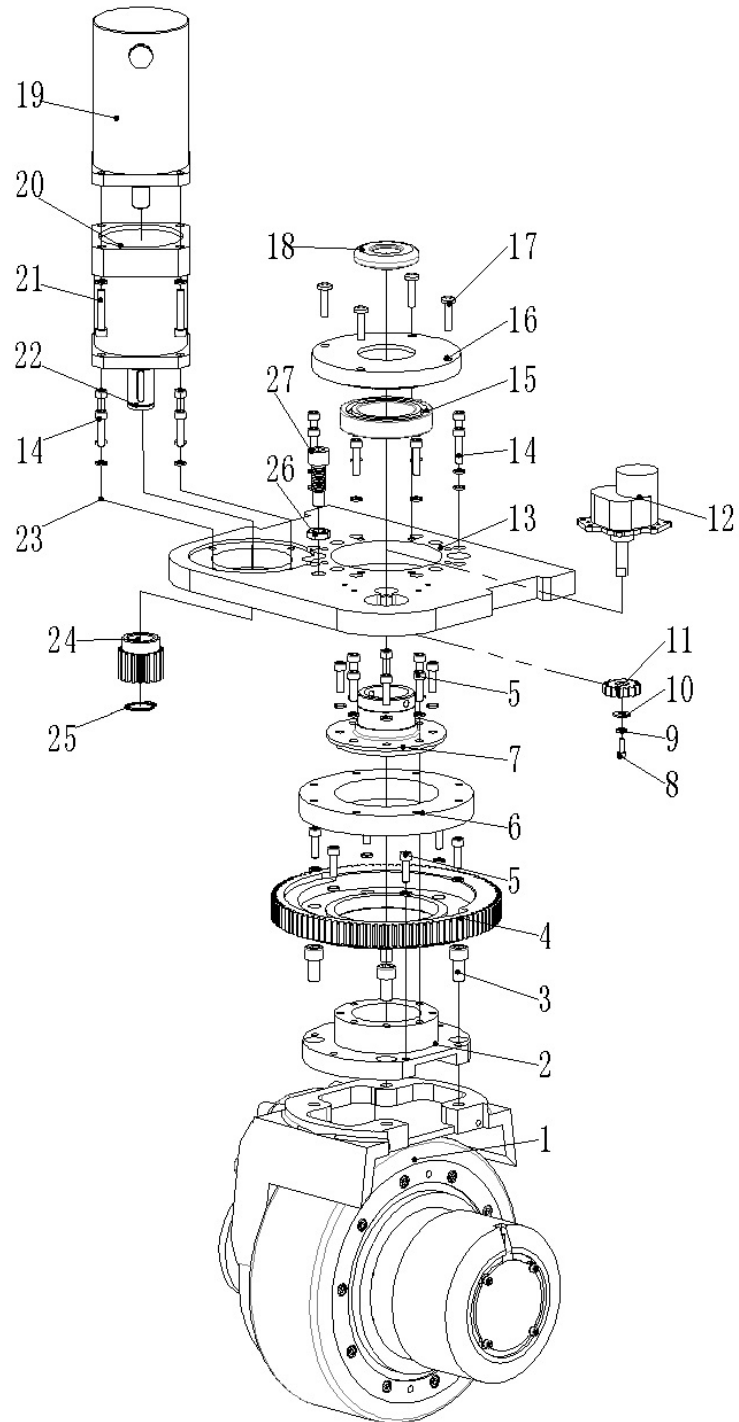

**Fig.31 Drive wheel(23EL)**

No.	Art No.	Description	Qty.	Note	Standard
1	9000007773	Drive wheel	1		
2	9000009200	Pivoting support	1		
3	0000023034	Screw	4	M10×20	GB/T70.1
4	9000009201	Steering big gear	1		
5	0000023020	Screw	24	M6×20	GB/T70.1
6	9000009202	Pivoting support	1		
7	9000009203	Bearing seat	1		
8	0000023056	Screw	1	M4×12	GB/T70
9	0000025009	Washer	1	4	GB/T93
10	0000025133	Washer	1	5	GB/T96
11	9000009204	Gear for sensor	1		
12	9000009205	Steering sensor	1		
13	9000009195	Welded wheel frame	1		
14	0000023030	Screw	12	M6×25	GB/T70
15	0000027065	Bearing	1	6010	GB/T276=ISO3290
16	9000009206	End cap	1		
17	0000023277	Screw	4	M6×25	GB/T818=ISO7045
18	9000009207	Rubber sleeve	1		
19	9000009208	Steering motor	1	200W24V	
20	9000009209	Steering motor gear box	1		
21	0000023090	Screw	4	M6×35	GB/T70
22	0090000118	Flat key	1	6×28	GB/T1096
23	0000025010	Washer	51	6	GB/T93
24	9000009210	Steering small gear	1		
25	0000026040	Circlip	1	22	GB/T894.1-1986
26	0000024116	Nut	1	M12	GB/T6172.1
27	9000009211	Screw	1		

Fig. 32 Instrument components

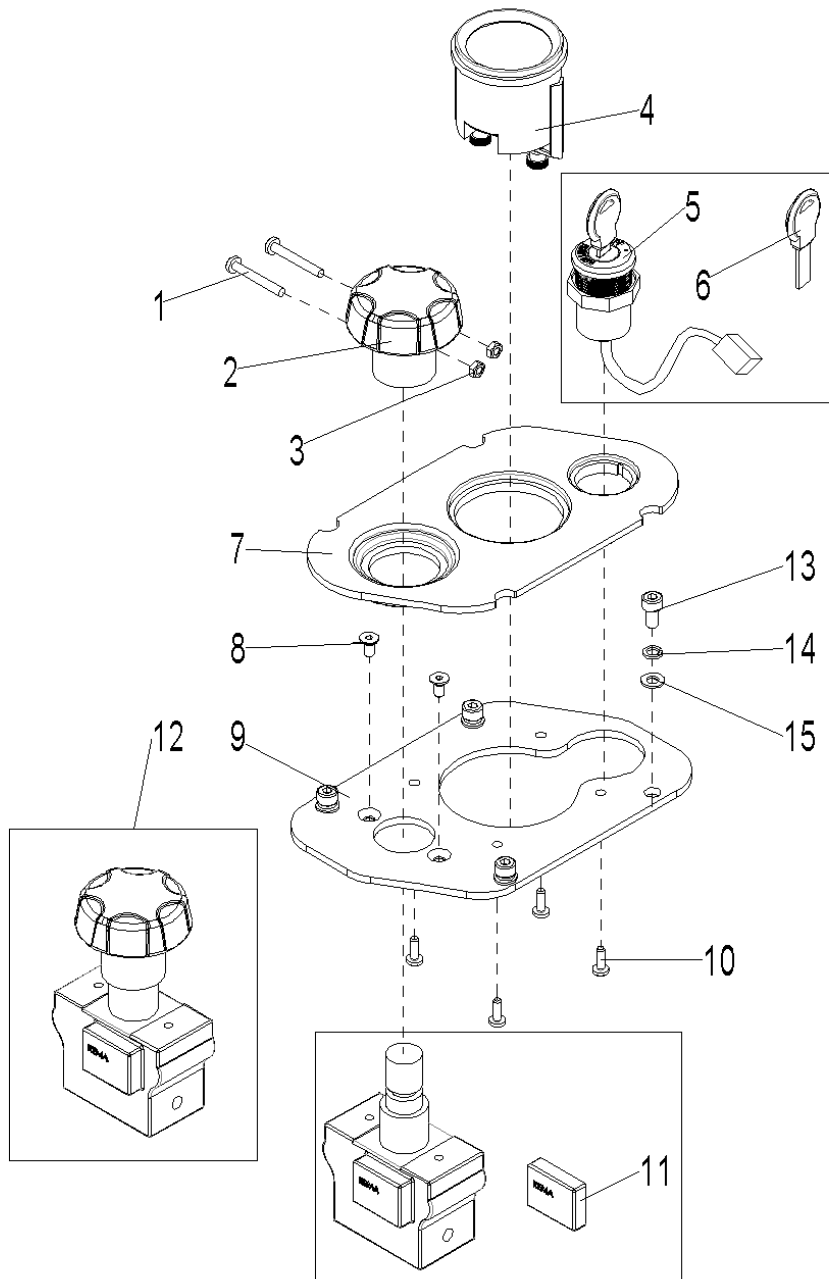

**Fig.32 Instrument Components**

No.	Art No.	Description	Qty.	Note	Standard
1	0000023685	Screw	2	M3×25	GB/T818=ISO7045
2	9000008516	DC power switch ZDK32-350 emergency button	1		
3	0000024002	Nut	2	M3	GB/T6170
4	1000434025	Indicator	1	CURTIS 803	
5	9000008326	Key switch	1	LKS-101A	
6	9000008519	Key	1		
7	9000007938	Plastic plate	1		
8	0000023215	Screw	2	M5×10	GB/T70.3
9	9000007939	Fixing plate	1		
10	0090000272	Screw	4	M4×12	GB/T6560
11	9000008517	Micro switch	1		
12	9000008515	DC power switch	1	ZDK32-350	
13	0000023053	Screw	3	M6X12	GB/T70.1=ISO4762
14	0000025010	Washer	3	6	GB/T93
15	0000023055	Washer	3	6	GB/T95

Fig. 33 Tiller arm assembly

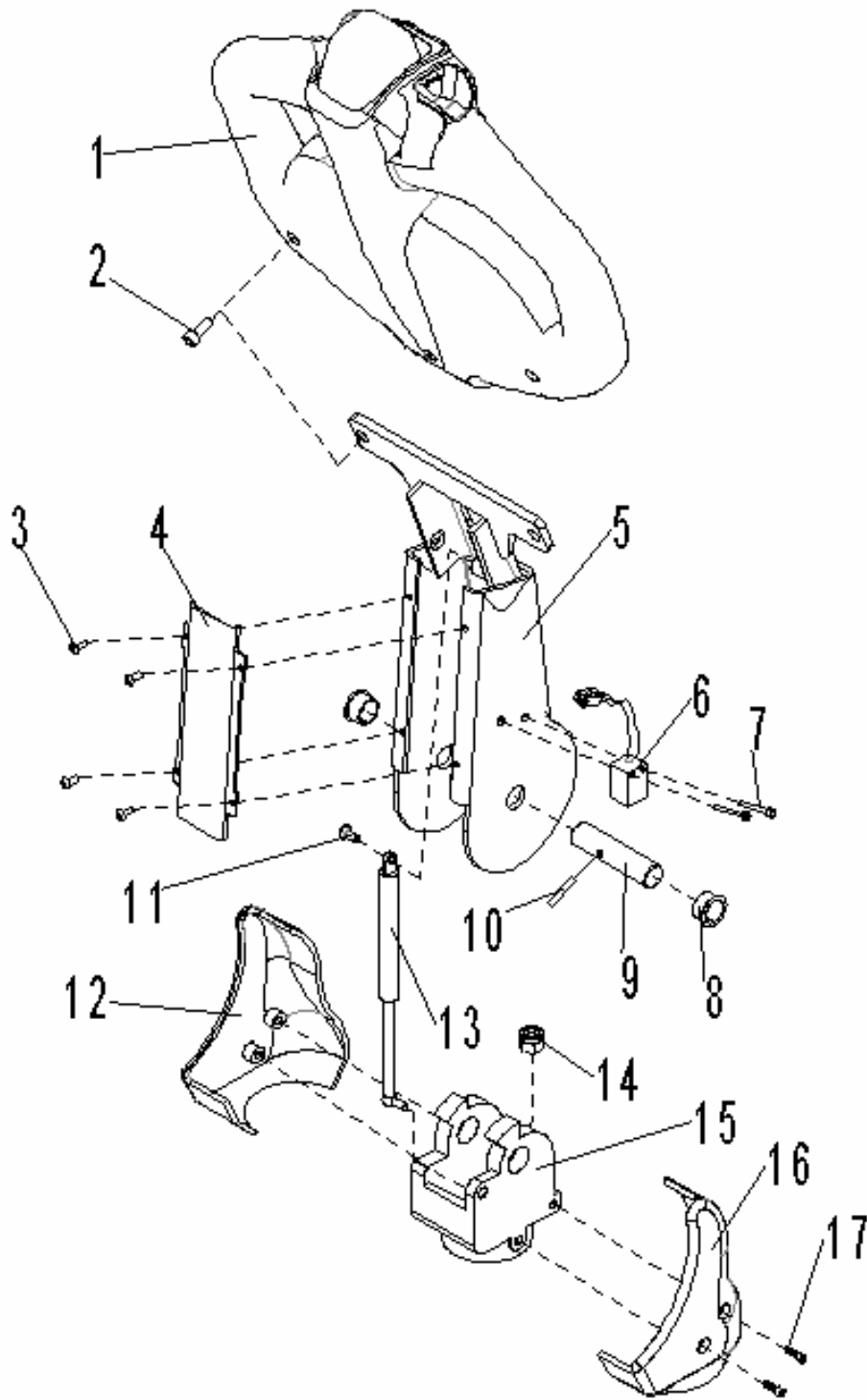
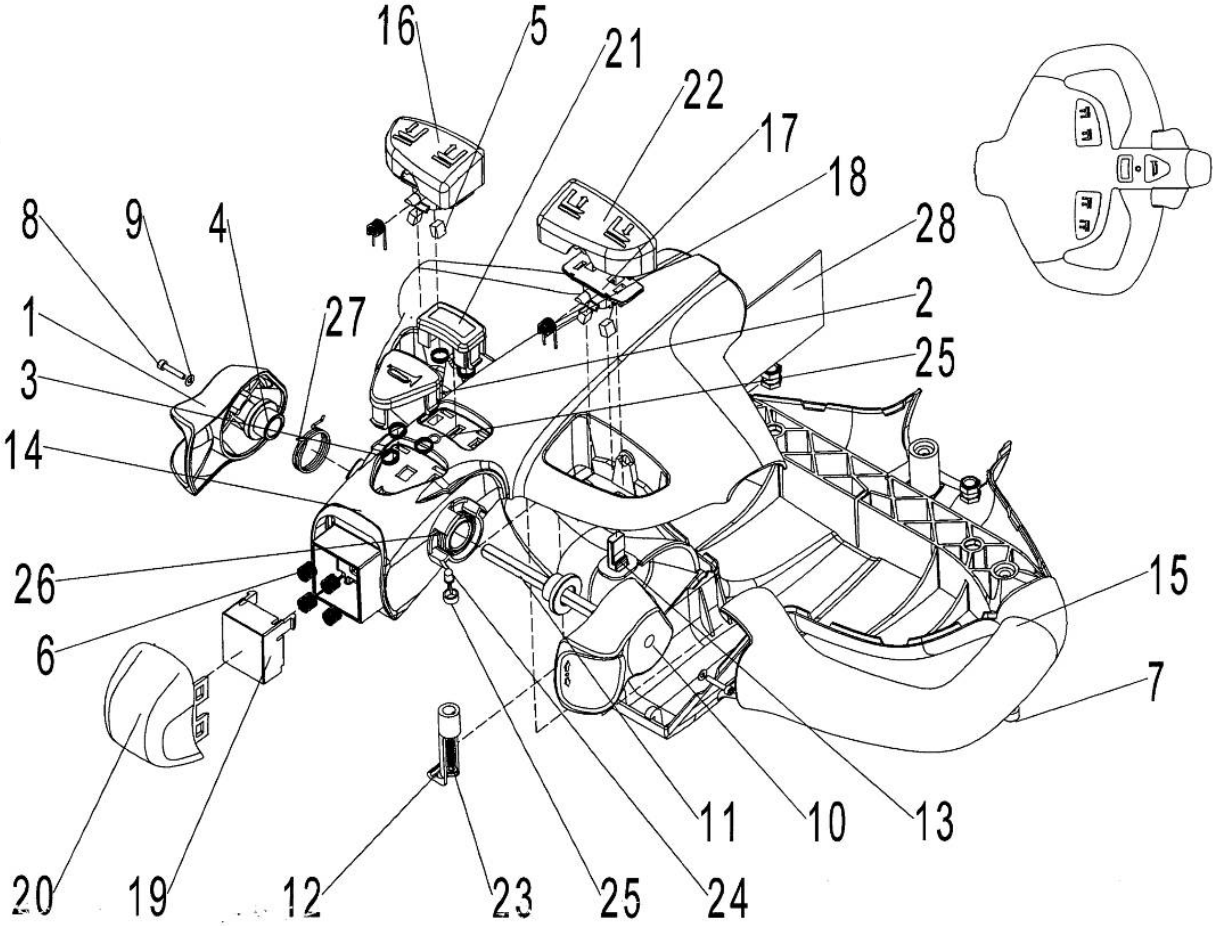



**Fig.33 Tiller arm assembly**

No.	Art No.	Description	Qty.	Note	Standard
1	1100100001	Canbus control tiller	1	C 94300-90 (REMA)	
2	0000023232	Bolt	2	M8×25	GB/T5783
3	1000123003	Screw	4	M4×8	GB/T70.2=ISO7380
4	9000007926	Cover board	1	with platform	
	9000009961	Long cover board	1	without platform	
5	9000007925	Welded tiller arm	1	with platform	
	9000009962	Welded long tiller arm	1	without platform	
6	9000008327	Proximity switch	1	NBN5-F7-E5	
7	0000023075	Screw	2	M3×20	GB/T70.1=ISO4762
8	1000113001	Shoulder harness	2	∅17×∅19×11	
9	9000007928	Tiller axle	1		
10	0000028003	Dowel pin	1	∅4×24	GB/T879.1
11	0000023044	Screw	1	M8×20	
12	9000007930	Left tiller cover	1		
13	1010121001	Air spring	1	400N	
14	0000023005	Lock nut	2	M10	GB/T889.1=ISO7040
15	9000007929	Tiller seat	1		
16	9000007931	Right tiller cover	1		
17	0000023519	Screw	4	M6×10	GB/T70.2=ISO7380

Fig. 34 Tiller head



**Fig.34 Tiller head**

No.	Art No.	Description	Qty.	Note	Standard
1	1000114014	Left driving button	1		
2	1000114015	Horn button	1		
3	1000131009	Spring for horn button	5		
4	1000113004	Bushing for camshaft	2		
5	1000137001	Magnet	4	▲	
6	1000131010	Spring for emergency button	4		
7	0000023058	Screw	3	M6×10	GB/T70.1=ISO4762
8	0000023057	Screw	2	M3×16	GB/T70.1=ISO4762
9	0000025017	Washer	2	3	GB/T95
10	1000114016	Right driving button	1		
11	1000107002	Shaft for driving button	1		
12	1000137002	PCB board terminal	1		
13	1000134005	Pressure sensor	2		
14	1000103012	Upper part of handle	1		
15	1000103013	Under part of handle	1		
16	1000114017	Left button	1		
17	1000137003	Magnet assembly seat	2		
18	1000131011	Torsional spring	2		
19	1000114018	Emergency button spring assembly seat	1		
20	1000114020	Emergency button	1		
21	1000114021	Option switch cover	1		
22	1000114022	Right elevator button	1		
23	0000023060	Screw	1	ST4.2×25	GB/T845
24	1000134006	LED bi-color light	1		
25	1000103014	LED bi-color light assembly seat	1		
26	1000131012	Torsional spring for left driving button	1		
27	1000131013	Torsional spring for right driving button	1		
28	1000134007	PCB	1		

## Easy worn parts list

No.	Art No.	Description	Qty.	Fig./Position	Note
1	9000007780	Air spring	1	Fig.4/5	Protective arm
2	9000007897	Positioning spring	1	Fig.4/9	
3	9000007799	Shoulder harness	4	Fig.5/3	Foldable platform
4	2000421001	Air spring	1	Fig.5/6	
5	9000008897	Suspension components	2	Fig.5/27	
6	0000027001	Bearing 6204	4	Fig.8/15	Steering wheel
7	2210416001	Castor	2	Fig.8/17	
8	9000008896	Wheel set	2	Fig.8/19	
9	2000416002	Load roller	4	Fig.9/4	Load wheel
10	0000027001	Bearing 6204	8	Fig.9/5	
11	9000008895	Wheel set	4	Fig.9/7	
12	9000007782	Spring buckle	10	Fig.10/6	Mast assembly
				Fig.10/9	
				Fig.10/10	
13	1000434040	Fuse 10A	1	Fig.13/3	Electronic control assembly(manual steering)
14	1020434001	Fuse 200A	1	Fig.13/14	
15	2210434004	Fuse 150A	1	Fig.13/15	
16	1020434001	Fuse 200A	1	Fig.14/14	Electronic control assembly(electrical steering)
17	2210434004	Fuse 150A	1	Fig.14/15	
18	1000434040	Fuse 10A	1	Fig.14/18	
19	3042434014	Fuse 15A	1	Fig.14/19	
20	2000322001	Dust ring	1	Fig.22/2	Cylinder(PS B12S One-stage mast)
21	2000322002	Support ring for shaft	1	Fig.22/3	
22	0000022013	O seal ring	1	Fig.22/6	
23	0000022014	O seal ring	2	Fig.22/8	
24	2000322003	Support ring for hole	1	Fig.22/9	
25	2010322001	Y seal ring	1	Fig.22/10	
26	9000009953	Seal kit	1	Fig.22/11	
27	2000335002	Carbon brush (component)	1	Fig.23/2	Pump system
28	9000009169	Dust ring	1	Fig.25/2	Cylinder(PS B12D)

29	9000009170	Y ring for shaft	1	Fig.25/3	Two-stage mast Lift)
30	9000009171	Support ring for shaft	1	Fig.25/4	
31	0090000491	O ring	1	Fig.25/5	
32	0000022029	O ring	1	Fig.25/8	
33	9000009177	Support ring for hole	1	Fig.25/9	
34	9000009178	Y ring for hole	1	Fig.25/10	
35	9000009954	Seal kit	1	Fig.25/2	
36	2000322001	Dust ring	1	Fig.27/2	Cylinder(PS B12F Two-stage mast Full-Free-Lift)
37	2000322002	Support ring for shaft	1	Fig.27/3	
38	0000022013	O seal ring	1	Fig.27/6	
39	0000022014	O seal ring	2	Fig.27/8	
40	2000322003	Support ring for hole	1	Fig.27/9	
41	2010322001	Y seal ring	1	Fig.27/10	
42	9000009955	Seal kit	1	Fig.27/1	
43	0000022002	O seal ring	1	Fig.31/18	Drive wheel(43EL)
44	1010121001	Air spring	1	Fig.33/13	Tiller arm assembly
45	1000113001	Shoulder harness	2	Fig.33/8	

# SPAREPARTS LIST

## Electric Stacker PS B15

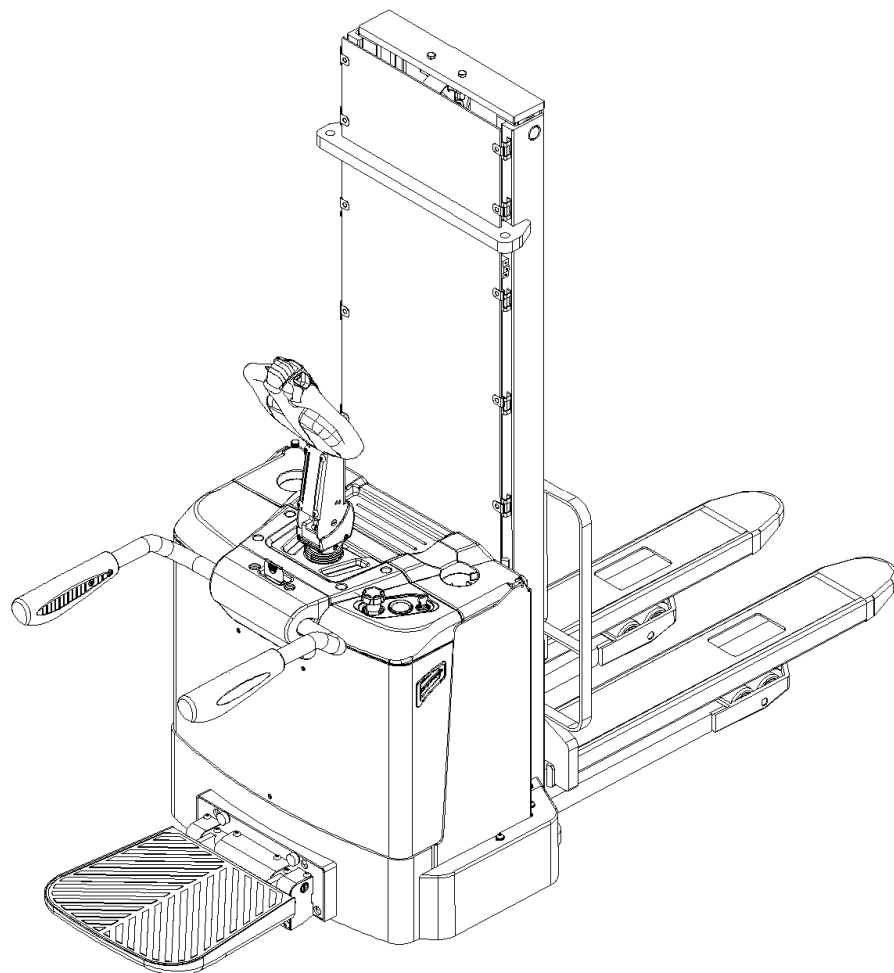

Version 10/2014

From truck identification number:

30130700011

PS B15-BPT-004-EN

# Catalogue

Fig. 1 Label (for EU) .....	3
Fig. 2 Label (for US) .....	4
Fig. 3 Outline .....	5
Fig. 4 Protective arm.....	7
Fig. 5 Foldable platform .....	8
Fig. 6 Battery cover assembly.....	10
Fig. 8 Steering wheel .....	12
Fig. 9 Load wheel .....	14
Fig. 10 Mast assembly(PS B15D Two-stage mast Lift) .....	15
Fig. 11 Mast assembly(PS B15F Two-stage mast Full-Free-Lift) .....	17
Fig. 12 Mast assembly(PS B15H/PS B15Z Three-stage mast ).....	19
Fig. 13 Electronic control assembly(manual steering) .....	21
Fig. 14 Electronic control assembly(electrical steering) .....	23
Fig. 15 Main harness(manual steering).....	25
Fig. 16 Main harness(electrical steering) .....	26
Fig. 17 Electric parts(manual steering) .....	27
Fig. 18 Electric parts(electrical steering).....	29
Fig. 19 Power supply .....	31
Fig. 20 Battery .....	33
Fig. 21 Hydraulic system(PS B15D Two-stage mast Lift).....	34
Fig. 22 Cylinder(PS B15D Two-stage mast Lift).....	36
Fig. 23 Hydraulic system(PS B15F Two-stage mast Full-Free-Lift).....	38
Fig. 24 Cylinder(PS B15F Two-stage mast Full-Free-Lift).....	42
Fig. 25 Hydraulic system(PS B15H Three-stage mast Lift).....	44
Fig. 26 Cylinder(PS B15H Three-stage mast Lift).....	46
Fig. 27 Pump system .....	48
Fig. 28 Hydraulic system(PS B15Z Three-stage mast Full-Free-Lift).....	50
Fig. 29 Cylinder (PS B15Z Three-stage mast Full-Free-Lift).....	54
Fig. 30 Middle cylinder(PS B15Z Three-stage mast Full-Free-Lift) .....	56
Fig. 31 Pump system(high pressure) .....	58

Fig. 32 Drive system(manual steering) .....	60
Fig. 33 Drive wheel(43EL) .....	62
Fig. 34 Drive system(electrical steering).....	66
Fig. 35 Drive wheel(23EL) .....	68
Fig. 36 Instrument components .....	70
Fig. 37 Tiller arm assembly .....	72
Fig. 38 Tiller head .....	74
Easy worn parts list.....	76



Fig. 1 Label (for EU)

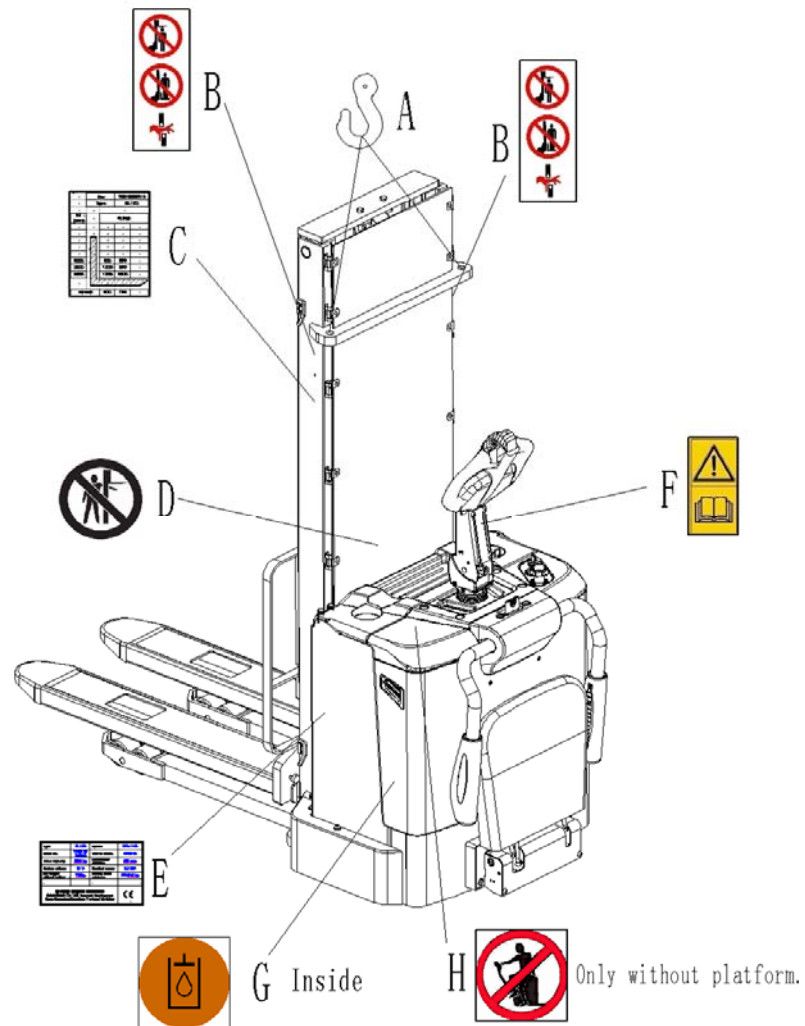

Fig. 1 Label (for EU)

No.	Parts No.	Item	Qty.	Note	Standard
A	900005967	Crane hook label	2		
B	900003923	Warning decal: Do not step under or on the forks	2		
C	900008664	Residual lift capacity sticker	1		
D	900008561	Never reach through	1		
E	900008663	Identification plate	1		
F	900003570	Sticker to read and follow these instructions	1		
G	900008555	Filling sticker	1		
H	900003573	'No passengers' decal	1		

Fig. 2 Label (for US)

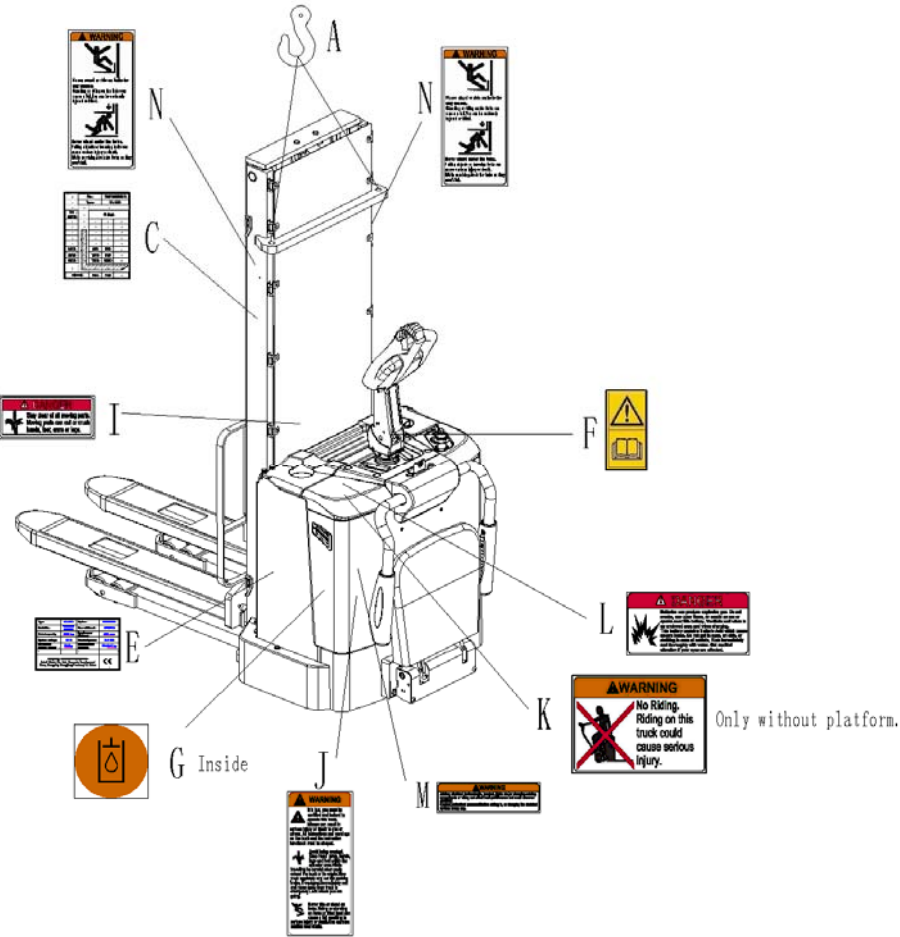
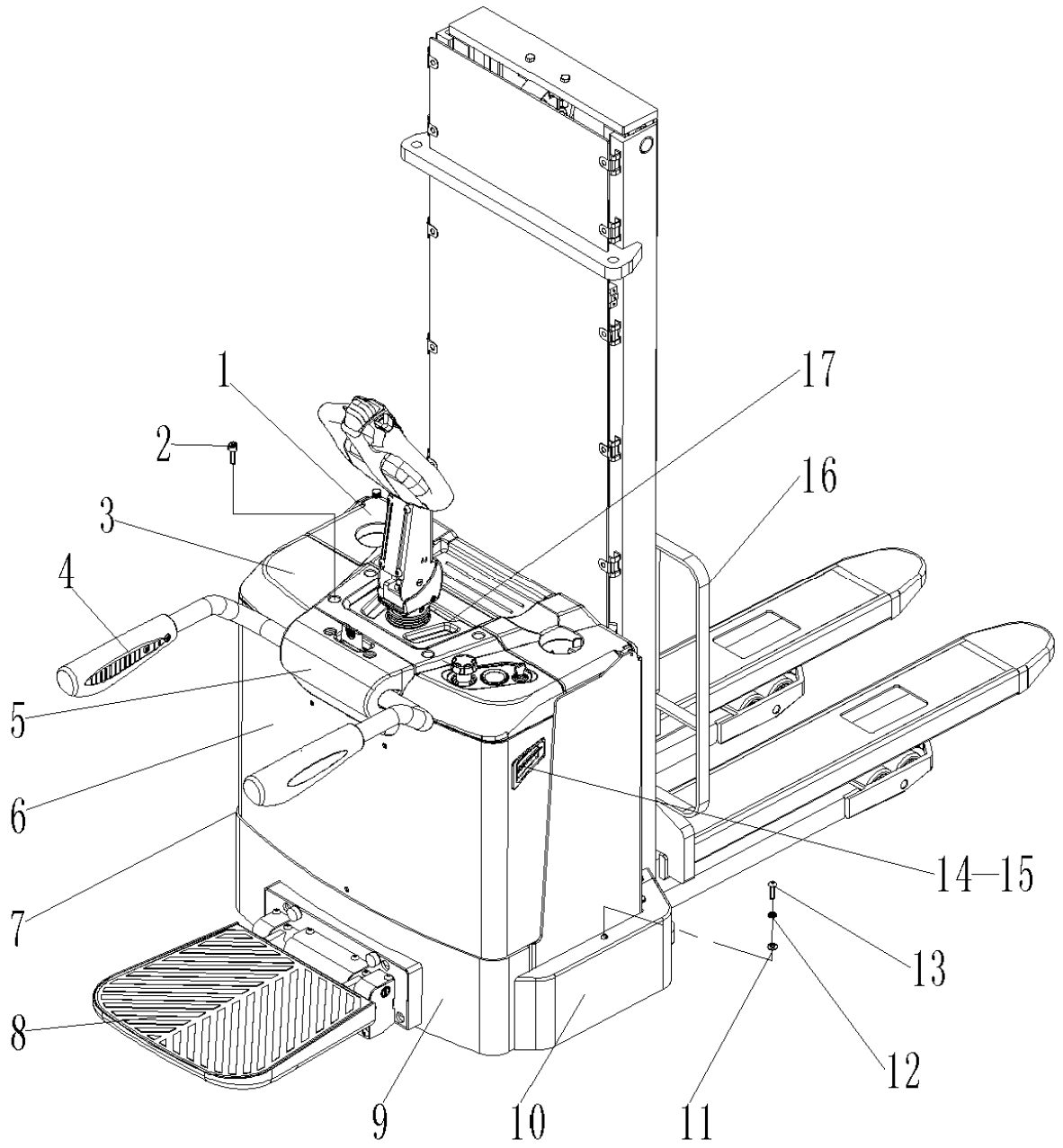

Fig. 2 Label (for US)

No.	Parts No.	Item	Qty.	Note	Standard
A	9000005967	Crane hook label	2		
C	9000008664	Residual lift capacity sticker	1		
E	9000008663	Identification plate (ID-plate)	1		
F	9000003570	Sticker to read and follow these instructions	1		
G	9000008555	Filling sticker	1		
I	9000005970	Warning label	1		
J	9000003575	Warning label	1		
K	9000003580	Warning label	1		
L	9000003577	Warning label	1		
M	9000003579	Warning label	1		
N	9000005971	Warning label	2		

Fig. 3 Outline



**Fig. 3 Outline**

No.	Art No.	Description	Qty.	Note	Standard
1	9000008128	Battery cover	1		
2	1000423003	Screw	8	M10×30	
3	9000008129	Upper cover	1		
4	9000007891	Protective arm assembly	1		
5	9000008063	Protective arm cover	1		
6	9000008126	Welded main cover	1		
7	9000008132	Welded left wheel cover	1	PS B15D/ PS B15F	
	9000009196			PS B15H/ PS B15Z	
8	9000007862	Foot pedal assembly	1		
9	9000008125	Welded truck body	1		
10	9000008136	Welded right wheel cover	1	PS B15D/ PS B15F	
	9000009197			PS B15H/ PS B15Z	
11	0000025002	Washer	6	10	GB/T95
12	0000023006	Washer	6	10	GB/T93
13	0000023857	Screw	6	M10×20	GB/T70.2=ISO7380
14	9000007920	Left vent components	1		
15	9000007923	Right vent components	1		
16	9000008259	Load backrest assembly	1		
17	9000008130	Middle cover	1		

Fig. 4 Protective arm

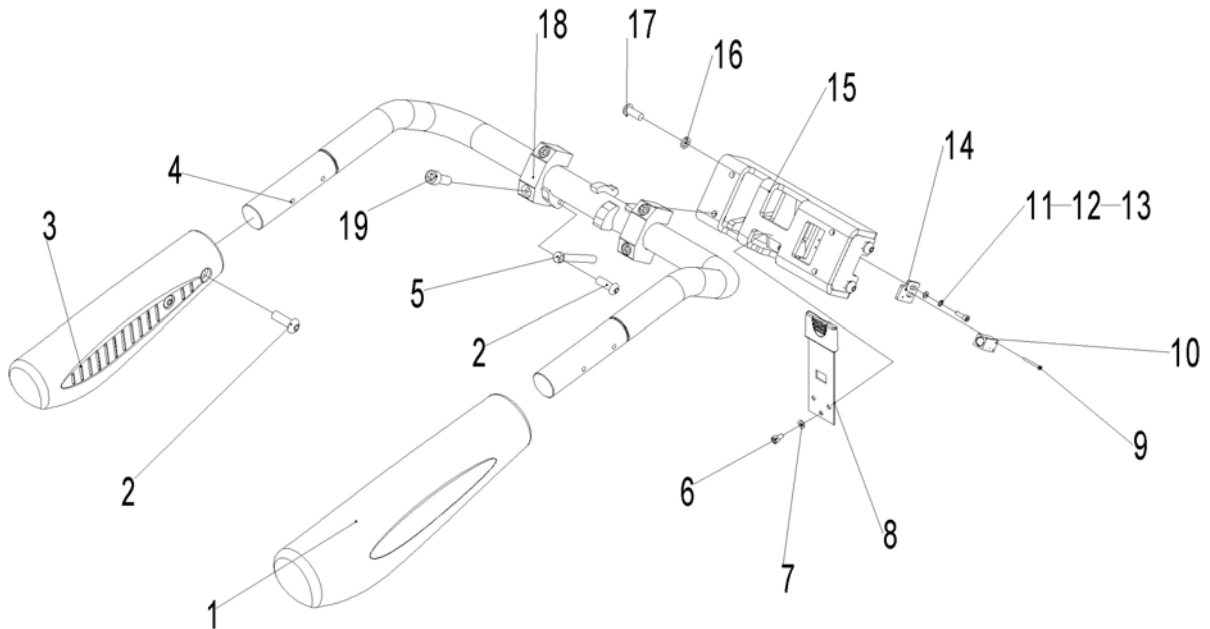
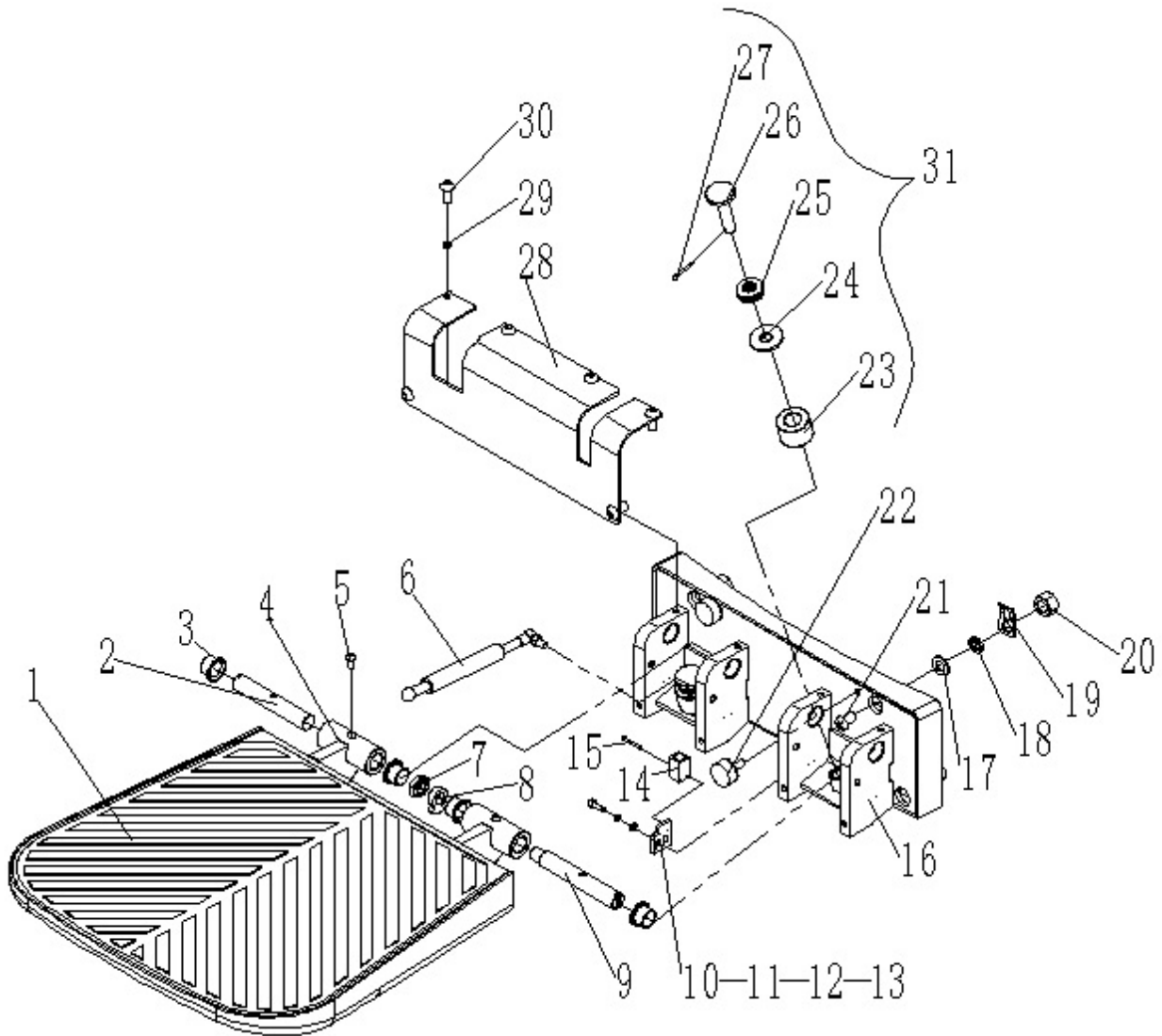

Fig. 4 Protective arm

No.	Art No.	Description	Qty.	Note	Standard
1	9000007895	Right protective arm cover	1		
2	0090000448	Screw	5	M8×20	GB/T70.2=ISO7380
3	9000007896	Left protective arm cover	1		
4	9000007894	Welded protective arm	1		
5	9000007780	Air spring	1		
6	0000023045	Screw	3	M6×12	GB/T70.2=ISO7380
7	0000025010	Washer	3	6	GB/T93
8	9000007897	Positioning spring	1		
9	0000023075	Screw	2	M3×20	GB/T70.1=ISO4762
10	9000008329	Proximity switch	1	NBN5-F7-E2	
11	0000025012	Washer	2	5	GB/T93
12	0000023032	Washer	2	5	GB/T95
13	0000023107	Screw	2	M5×16	GB/T70.1=ISO4762
14	9000009799	Switch transition plate	1		
15	9000007892	Welded protective arm seat	1		
16	0000023006	Washer	4	10	GB/T93
17	0090000447	Screw	4	M10×25	GB/T70.2=ISO7380
18	9000007893	Protective arm clamp block	2		
19	0000023099	Screw	4	M10×45	

Fig. 5 Foldable platform



**Fig. 5 Foldable platform**

No.	Art No.	Description	Qty.	Note	Standard
1	9000007867	Pedal pad	1		
2	9000007869	Rotating shaft	1		
3	9000007799	Shoulder harness	4	∅20×∅23×16.5	
4	9000007863	Welded foot platform	1		
5	0000023555	Screw	2	M6×16	GB/T70.2=ISO7380
6	2000421001	Air spring	1		
7	0000024014	Nut	1	M16×1.5	GB/T6173 =ISO8675
8	9000007873	Cam	1		
9	9000007866	Cam shaft	1		
10	0000025012	Washer	2	5	GB/T93
11	0000023032	Washer	2	5	GB/T95
12	0000023107	Screw	2	M5×16	GB/T70.1=ISO4762
13	9000009799	Switch transition plate	1		
14	9000008328	Proximity switch	1	NBN5-F7-E2	
15	0000023075	Screw	2	M3×20	GB/T70.1=ISO4762
16	9000007864	Welded assembly seat	1		
17	0090000048	Washer	4	12	GB/T97.1
18	0000025024	Washer	4	12	GB/T93
19	9000007874	Line hanging board	1		
20	0000024006	Lock nut	4	M12	GB/T889.1=ISO7040
21	0090000450	Screw	4	M12×45	GB/T70.2=ISO7380
22	9000007865	Damping pad	2		
23	9000007872	Anti-vibration pad	2		
24	9000007871	Anti-vibration washer	2		
25	0000031001	Spring	8	∅16.3×∅31.5× 1.75	GB/T1972
26	9000007870	Fixed bolt	2		
27	0000028033	Split pin	2	∅3.2×20	GB/T91
28	9000007868	Assembly seat cover	1		
29	0000025010	Washer	6	6	GB/T93
30	0000023045	Screw	6	M6×12	GB/T70.2=ISO7380
31	9000008897	Suspension components	2		

Fig. 6 Battery cover assembly

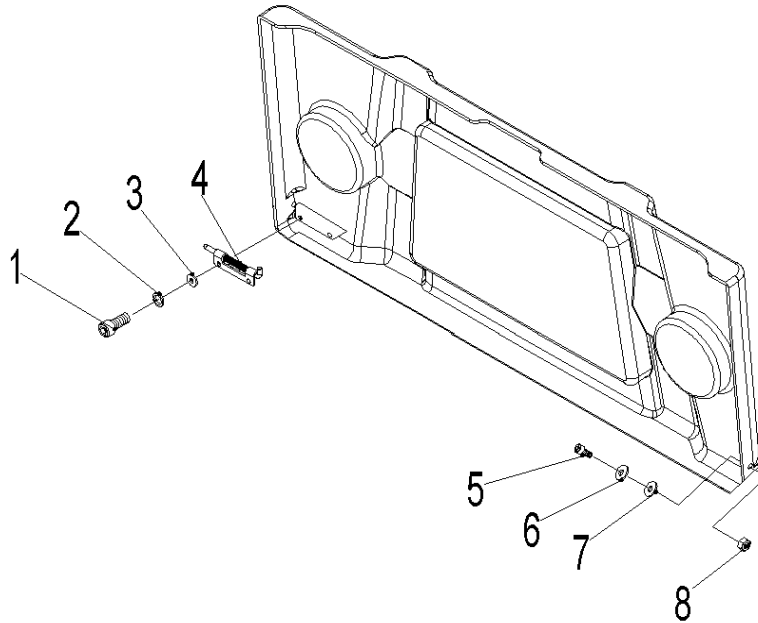

Fig. 6 Battery cover assembly

No.	Art No.	Description	Qty.	Note	Standard
1	0000023073	Screw	2	M4×10	GB/T70.1=ISO4762
2	0000025018	Washer	2	4	GB/T93
3	0000025019	Washer	2	4	GB/T95
4	9000008795	Bolt	1	CL037	
5	0000023306	Screw	1	M5×20	GB/T70.1=ISO4762
6	0000025015	Washer	1	5	GB/T93
7	0000025014	Washer	1	5	GB/T95
8	0000024035	Nut	1	M5	GB/T6170



Fig. 7 Chassis

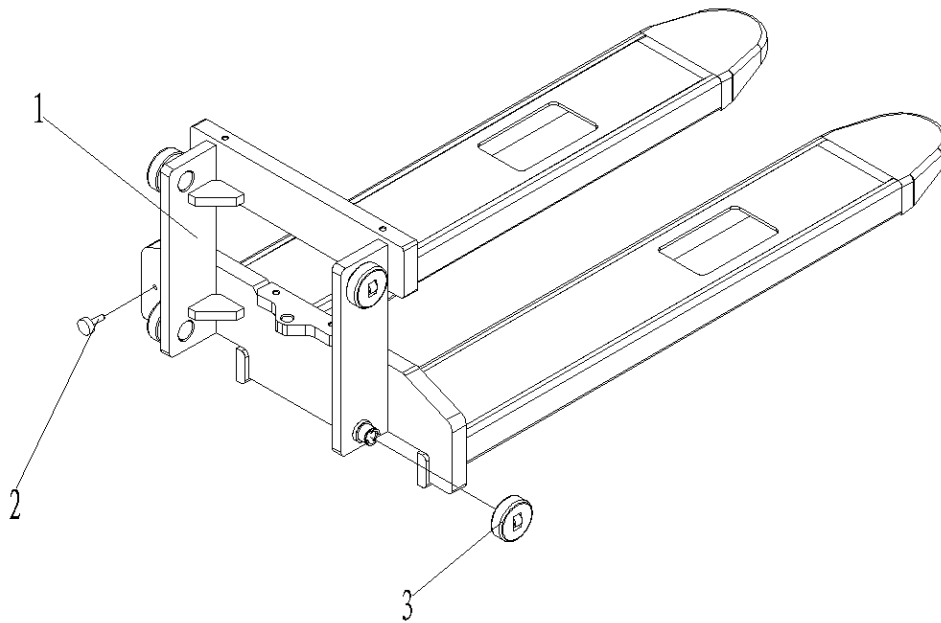
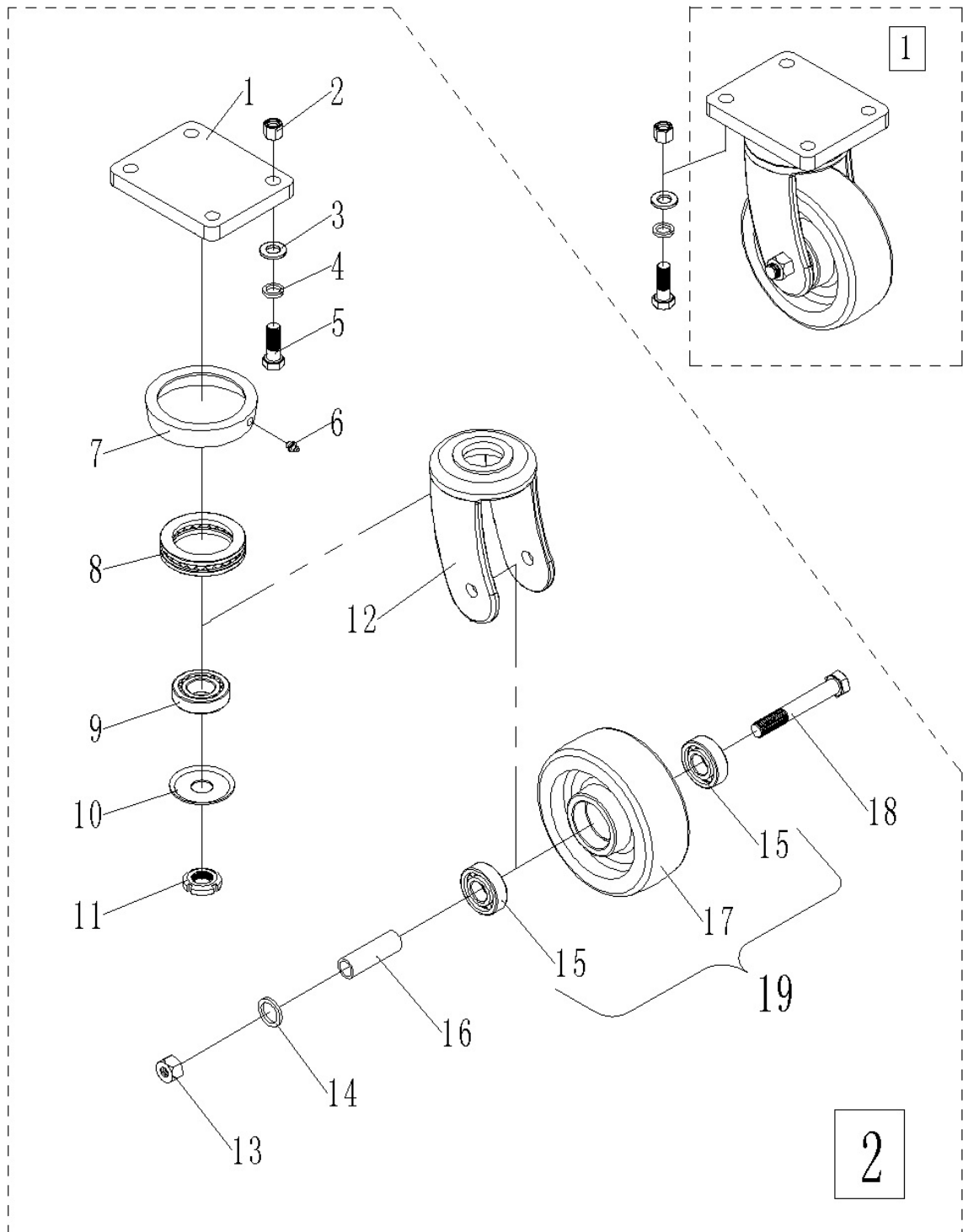

Fig. 7 Chassis

No.	Art No.	Description	Qty.	Note	Standard
1	9000009097	Welded chassis	1	PS B15D / PS B15F	
	9000009098	Welded chassis	1	PS B15D / PS B15F	
	9000009106	Welded chassis	1	PS B15H / PS B15Z	
	9000009107	Welded chassis	1	PS B15H / PS B15Z	
2	2000435002	Magnet steel	1		
3	2220511001	Compound roller	4		

Fig. 8 Steering wheel



**Fig. 8 Steering wheel**

No.	Art No.	Description	Qty.	Note	Standard
1	2240401006	Welded flange	2		
2	0000024006	Lock nut	8	M12	GB/T889.1=ISO7040
3	0000025032	Washer	8	12	GB/T95
4	0000025024	Washer	8	12	GB/T93
5	0000023122	Screw	8	M12×50	GB/T70.1=ISO4762
6	0000030002	Oil cup	2	M6	JB/T7940.1
7	2210422001	Dust ring	2		
8	0000027014	Bearing	2	8111	GB/T301
9	0000027015	Bearing	2	7205E	GB/T297
10	2210404001	Pressing cover	2		
11	0000024016	Nut	2	M20×1.5	GB/T812
12	2210405001	Frame of roller	2		
13	0000024015	Lock nut	2	M14	GB/T889.1=ISO7040
14	2210425001	Washer	4		
15	0000027001	Bearing	4	6204	GB/T276=ISO3290
16	2210413001	Bearing sleeve	2		
17	2210416001	Castor	2		
18	0000023111	Bolt	2	M14×100	GB/T5782=ISO4014
19	9000008896	Wheel set	1		
①	2210400001	Steering wheel	2		
②	9000010410	Steering wheel accessories	2		

Fig. 9 Load wheel

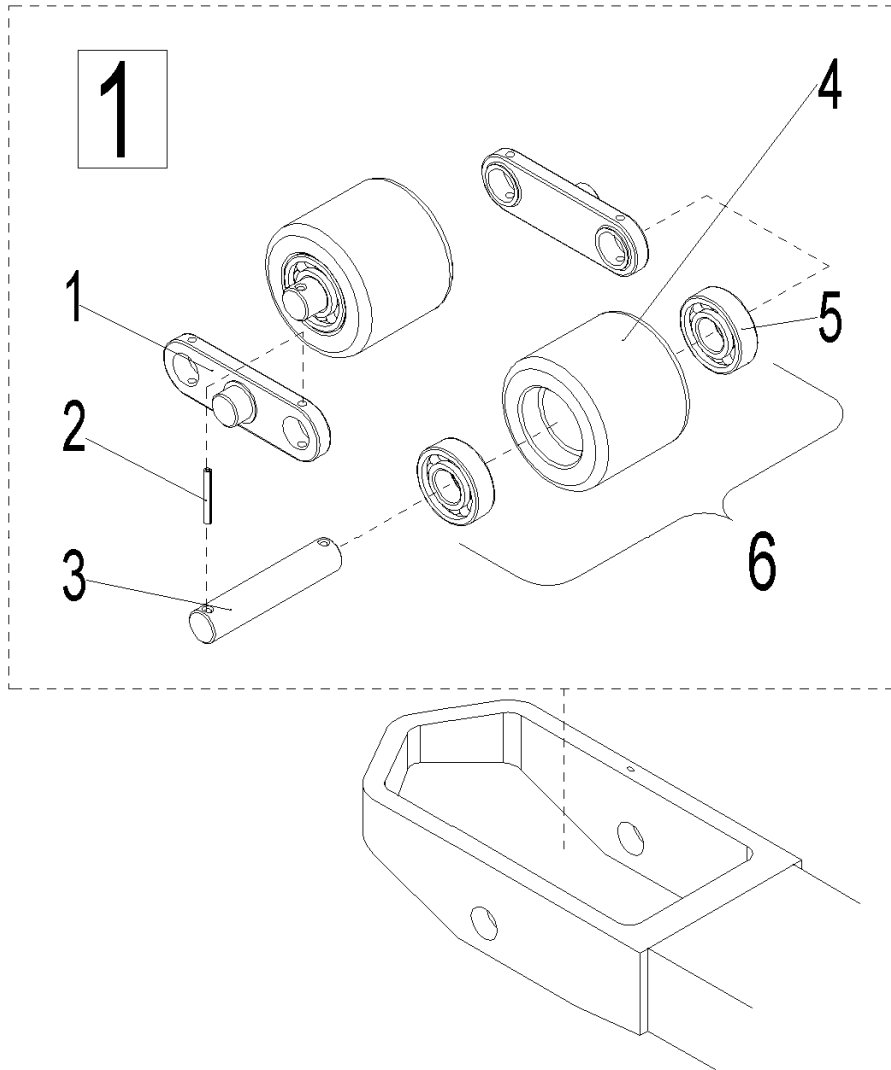
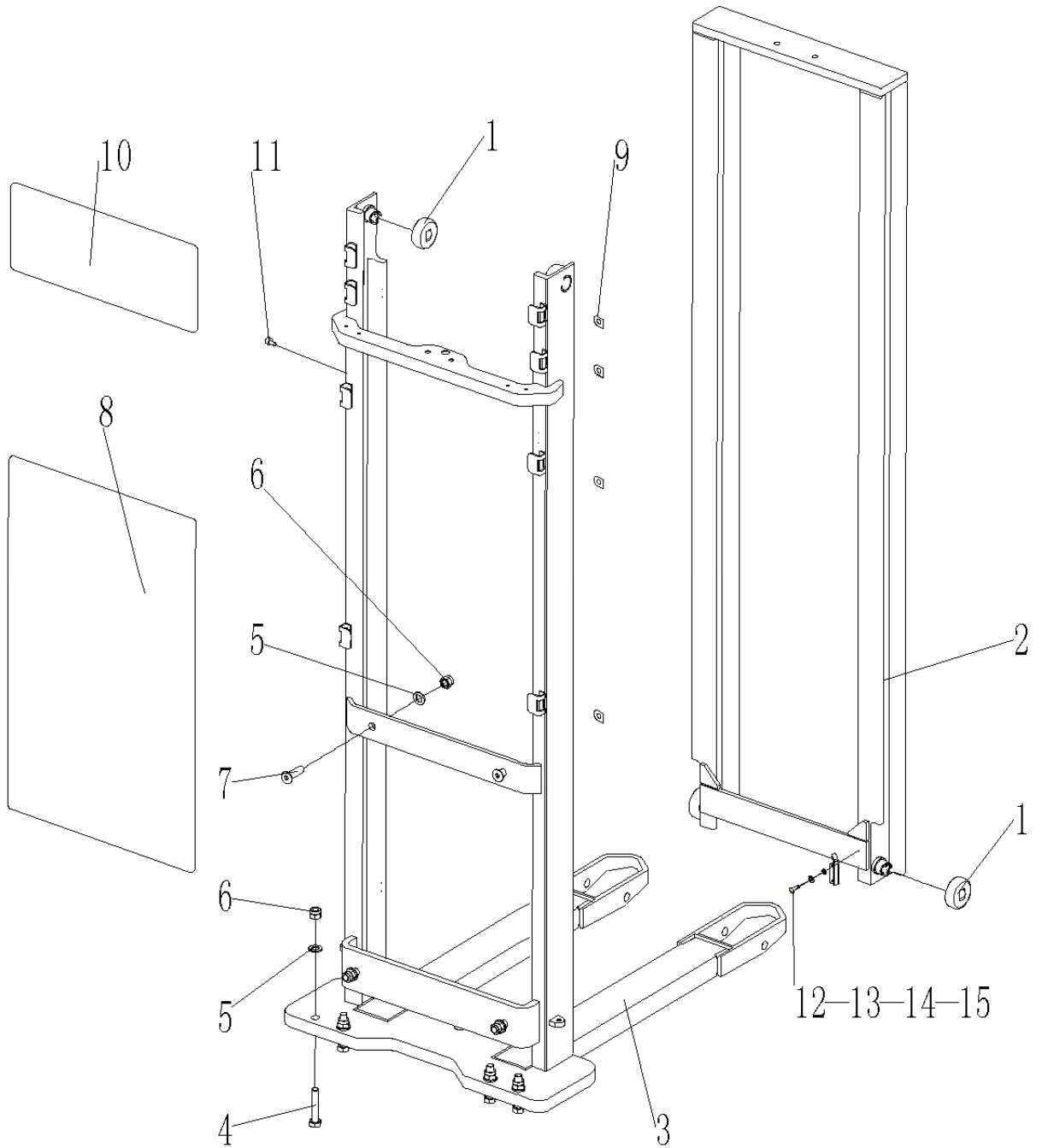

Fig. 9 Load wheel

No.	Art No.	Description	Qty.	Note	Standard
1	2000405002	Connecting plate	2		
2	0000028009	Dowel pin	4	∅5×35	GB/T879.1
3	2000407001	Shaft for load roller	2		
4	2000416002	Load roller	2	∅80×70	
5	0000027001	Bearing	4	6204	GB/T276=ISO3290
6	9000010398	Wheel set	2		
①	2000600001	Load roller assembly	2		

Fig. 10 Mast assembly(PS B15D Two-stage mast Lift)



**Fig. 10 Mast Assembly(PS B15D Two-stage mast Lift)**

No.	Art No.	Description	Qty.	Note	Standard
1	2040511001	Compound roller 1	4		
2	9000008973	Welded inner mast	1	2900	
3	9000009099	Welded outer mast	1	2900;570×1150	
	9000009100			2900;685×1150	
4	0090000486	Screw	4	M16×80	GB/T70.1=ISO4762
5	0000025029	Washer	8	16	GB/T95
6	0000024011	Lock nut	8	M16	GB/T889.1=ISO7040
7	2210423001	Screw	4	M16×52	
8	9000009101	Protective glass	1	2900	
9	9000007782	Spring buckle	8		
10	9000009102	Top glass	1		
11	0090000189	Screw	1	M4x8	
12	9000008981	Limit board	1		
13	0000023056	Screw	2	M4x12	GB/T70.1=ISO4762
14	0000025018	Washer	2	4	GB/T93
15	0000025019	Washer	2	4	GB/T95

Fig. 11 Mast assembly(PS B15F Two-stage mast Full-Free-Lift)

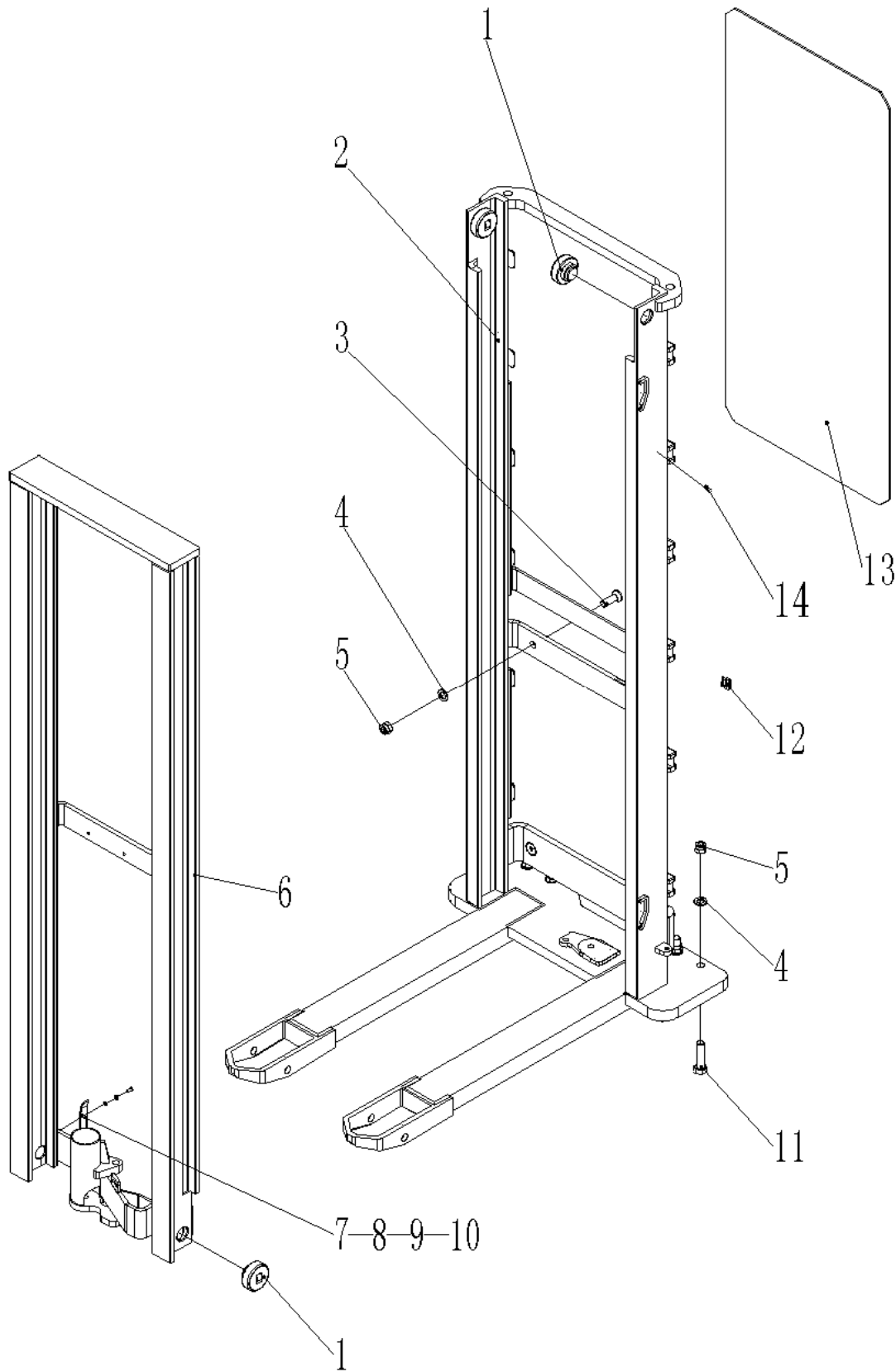
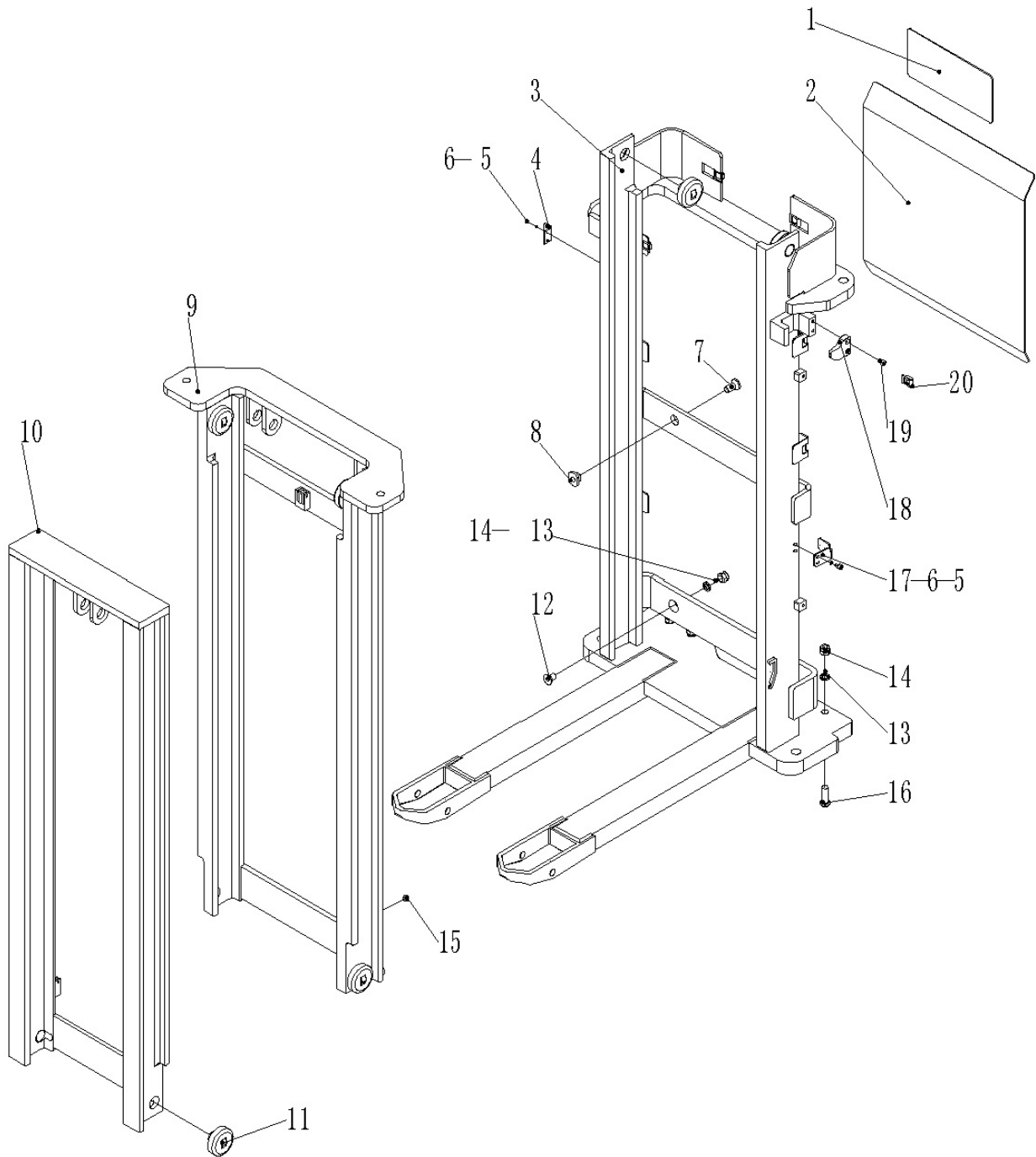

**Fig. 11 Mast Assembly(PS B12F Two-stage mast Full-Free-Lift)**

No.	Art No.	Description	Qty.	Note	Standard
1	2040511001	Compound roller 1	4		
2	9000009103	Welded outer mast	1	2900;570×1150	
	9000009104			2900;685×1150	
3	2210423001	Screw	4	M16×52	
4	0000025029	Washer	8	16	GB/T95
5	0000024011	Lock nut	8	M16	GB/T889.1=ISO7040
6	9000008999	Welded inner mast	1	2900	
7	9000008112	Limit board	1		
8	0000023853	Screw	2	M4×16	GB/T70.1=ISO4762
9	0000025009	Washer	2	4	GB/T93
10	0000025019	Washer	2	4	GB/T95
11	0090000486	Screw	4	M16×80	GB/T70.1=ISO4762
12	9000007782	Spring buckle	6		
13	9000009105	Protective glass	1	2900	
14	0090000189	Screw	1	M4x8	GB/T70.3



Fig. 12 Mast assembly(PS B15H/PS B15Z Three-stage mast )



**Fig. 12 Mast Assembly(PS B15H/PS B15Z Three-stage mast)**

No.	Art No.	Description	Qty.	Note	Standard
1	9000009117	Top glass	1		
2	9000009116	Protective glass	1		
3	9000009108	Welded outer mast (3400;570×1150)	1	PS B15H	
	9000009109	Welded outer mast (3400;685×1150)	1	PS B15H	
	9000009124	Welded outer mast (3400;570×1150)	1	PS B15Z	
	9000007714	Welded outer mast (3400;685×1150)	1	PS B15Z	
4	9000009118	Micro switch fixing plate	1		
5	0000025018	Washer	2	4	GB/T93
6	0000023056	Screw	2	M4×12	GB/T70.1=ISO4762
7	9000007794	Screw	2	M16×38	
8	9000009122	Nut	2	M16	
9	9000009110	Welded middle mast (3400)	1	PS B15H	
	9000009125			PS B15Z	
10	9000009111	Welded inner mast (3400)	1	PS B15H	
	9000009128			PS B15Z	
11	2040511001	Compound roller 1	8		
12	2210423001	Screw	2	M16×52	
13	0000025029	Washer	6	16	GB/T95
14	0000024011	Lock nut	6	M16	GB/T889.1=ISO7040
15	0090000486	Screw	4	M16×80	GB/T70.1=ISO4762
16	9000009121	Magnet switch holder	1		
17	0000025018	Washer	2	4	GB/T93
18	0000023056	Screw	2	M4×12	GB/T70.1=ISO4762
19	3018005004	Cylinder pressing board	2		
20	0000023044	Screw	4	M8×20	GB/T70.1=ISO4762
21	9000007782	Spring buckle	6		
22	2000435002	Magnet steel	1		

Fig. 13 Electronic control assembly(manual steering)

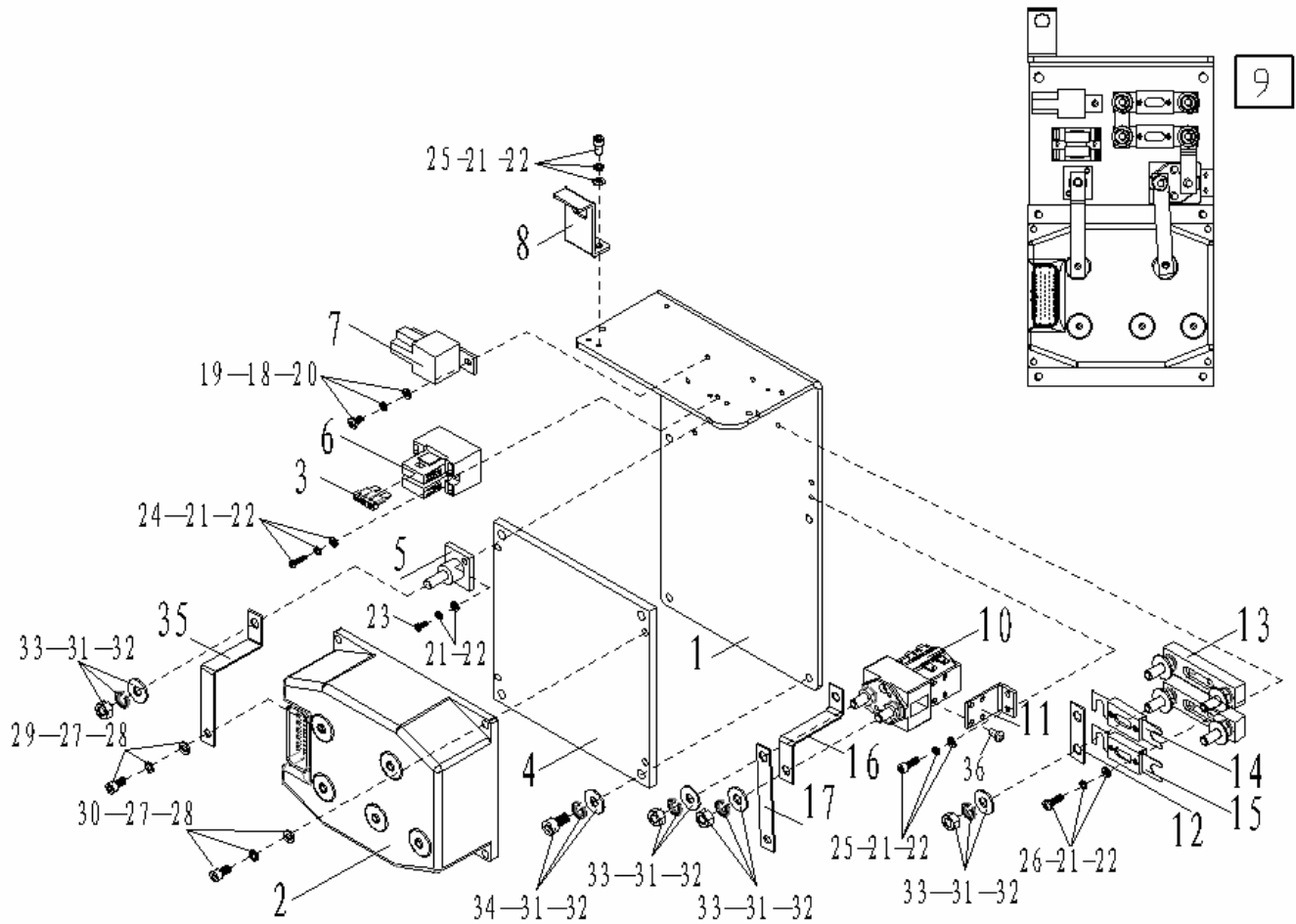

Fig. 13 Electronic control assembly(manual steering)

No.	Art No.	Description	Qty.	Note	Standard
1	9000008138	Controller assembly plate	1		
2	9000000235	Controller CURTIS	1	1232E-2121	

3	1000434040	Fuse	1	10A	
4	9000008376	Aluminium plate	1		
5	1020434002	Wiring terminal	1	BD-M8	
6	9000008586	Fuse seat	1	BD-2×10A	
7	1000434041	Pump contactor	1	DC24V	
8	9000008585	Plug fixing plate	1		
9	9000008409	Controller components	1		
10	1000434006	Traction motor contactor	1	DC24V	
11	9000008598	Main contactor assembly plate	1		
12	1020434003	Copper bar	1		
13	1000434007	Fuse seat	2	SYF	
14	1020434001	Fuse	1	200A	
15	2210434004	Fuse	1	150A	
16	9000008374	Copper bar	1		
17	9000008373	Copper bar	1		
18	0000023516	Screw	3	M5×10	GB/T818=ISO7045
19	0000025015	Washer	1	5	GB/T93-
20	0000025014	Washer	1	5	GB/T95
21	0000025018	Washer	12	4	GB/T93
22	0000025019	Washer	12	4	GB/T95
23	0000023073	Screw	2	M4×10	GB/T818=ISO7045
24	0000023019	Screw	2	M4×30	GB/T818=ISO7045
25	0000023307	Screw	4	M4×10	GB/T818=ISO7045
26	0000023211	Screw	4	M4×16	GB/T818=ISO7045
27	0000025010	Washer	9	6	GB/T93
28	0000023055	Washer	9	6	GB/T95
29	0000023478	Screw	5	M6×12	GB/T70.1=ISO4762
30	0000023923	Screw	4	M6×18	GB/T70.1=ISO4762
31	0000025001	Washer	11	8	GB/T93
32	0000025011	Washer	11	8	GB/T95
33	0000024086	Nut	11	M8	GB/T6170
34	0000023067	Screw	4	M8×16	GB/T70.1=ISO4762
35	9000008372	Copper bar	1		
36	0000023727	Screw	2	M4×6	GB/T818=ISO7045

Fig. 14 Electronic control assembly(electrical steering)

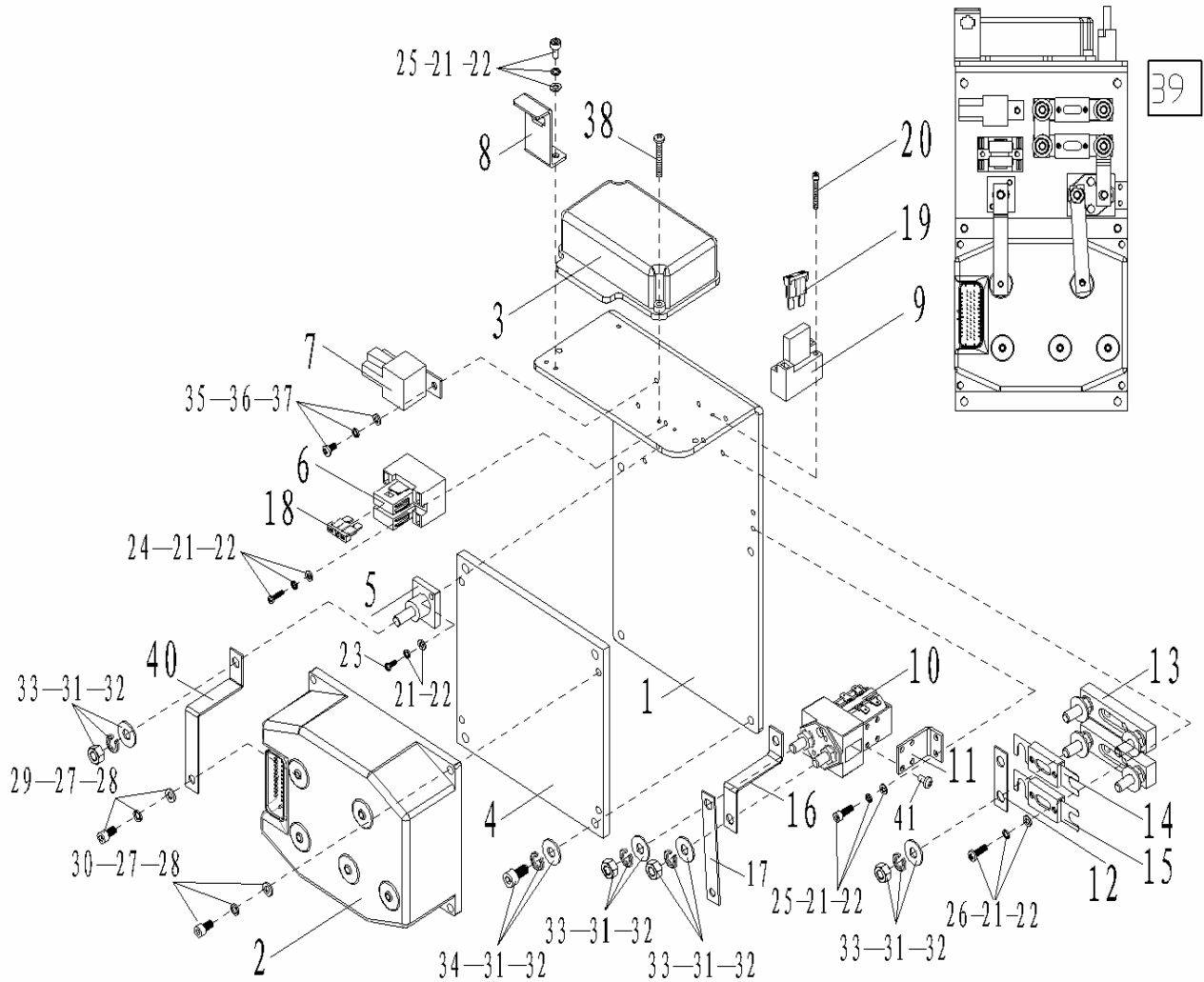

Fig. 14 Electronic control assembly(electrical steering)

No.	Art No.	Description	Qty.	Note	Standard
1	9000008138	Controller assembly plate	1		
2	9000000235	Controller CURTIS	1	CURTIS1232E-2121	
3	9000000236	Steering controller	1	BD-SC-24/10	
	9000008451		1	BD-SC-24/10-3	
4	9000008376	Aluminium plate	1		
5	1020434002	Wiring terminal	1	BD-M8	
6	9000008586	Fuse seat	1	BD-2×10A-1	
7	1000434041	Pump contactor	1	DC24V	

8	9000008585	Plug fixing frame	1		
9	1000434021	Fuse seat	1	BD-1×10A	
10	1000434006	Traction motor contactor	1	DC24V	
11	9000008598	Main contactor assembly plate	1		
12	1020434003	Copper bar	1		
13	1000434007	Fuse seat	2	SY Y	
14	1020434001	Fuse	1	200A	
15	2210434004	Fuse	1	150A	
16	9000008374	Copper bar	1		
17	9000008373	Copper bar	1		
18	1000434040	Fuse	1	10A	
19	3042434014	Fuse	1	15A	
20	0000023070	Screw	2	M3×25	GB/T70.1=ISO4762
21	0000025018	Washer	12	4	GB/T93
22	0000025019	Washer	12	4	GB/T95
23	0000023073	Screw	2	M4×10	GB/T70.1=ISO4762
24	0000023019	Screw	2	M4×30	GB/T818=ISO7045
25	0000023307	Screw	4	M4×10	GB/T818=ISO7045
26	0000023211	Screw	4	M4×16	GB/T818=ISO7045
27	0000025010	Washer	9	6	GB/T93
28	0000023055	Washer	9	6	GB/T95
29	0000023478	Screw	5	M6×12	GB/T70.1=ISO4762
30	0000023923	Screw	4	M6×18	GB/T70.1=ISO4762
31	0000025001	Screw	12	8	GB/T93
32	0000025011	Washer	11	8	GB/T95
33	0000024086	Nut	12	M8	GB/T6170
34	0000023067	Screw	4	M8×16	GB/T70.1=ISO4762
35	0000023516	Screw	3	M5×10	GB/T818=ISO7045
36	0000025015	Washer	1	5	GB/T93
37	0000025014	Washer	1	5	GB/T95
38	0090000082	Screw	2	M4×30	GB/T70.1=ISO4762
39	9000008597	Electrical control assembly	1		
40	9000008372	Copper bar	1		
41	0000023727	Screw	2	M4×6	GB/T818=ISO7045

Fig. 15 Main harness(manual steering)

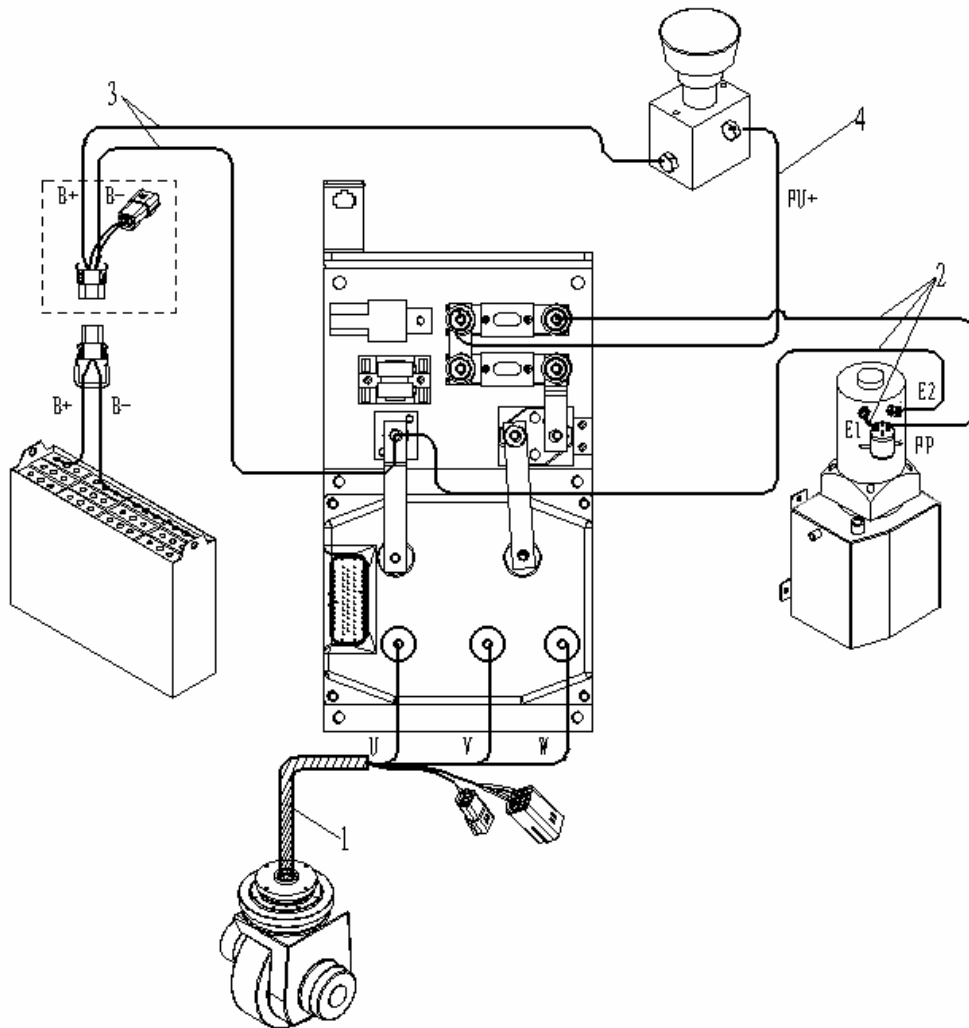

Fig. 15 Main Harness(manual steering)

No.	Art No.	Description	Qty.	Note	Standard
1	900008405	Drive motor cable	1		
2	900008406	Pump motor cable	1		
3	900008407	Power supply cable	1		
4	900008408	FU+ cable	1		

Fig. 16 Main harness(electrical steering)

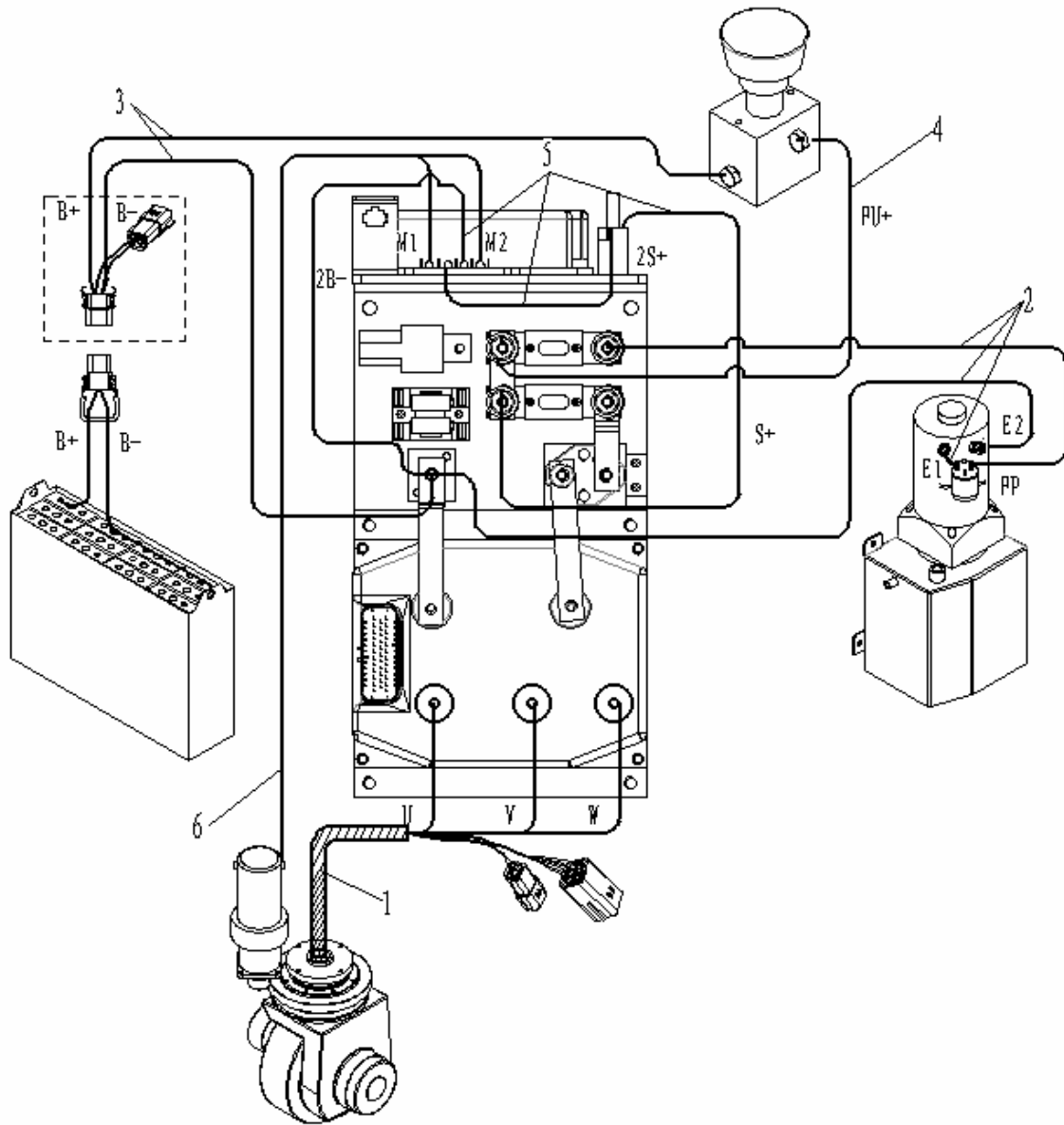
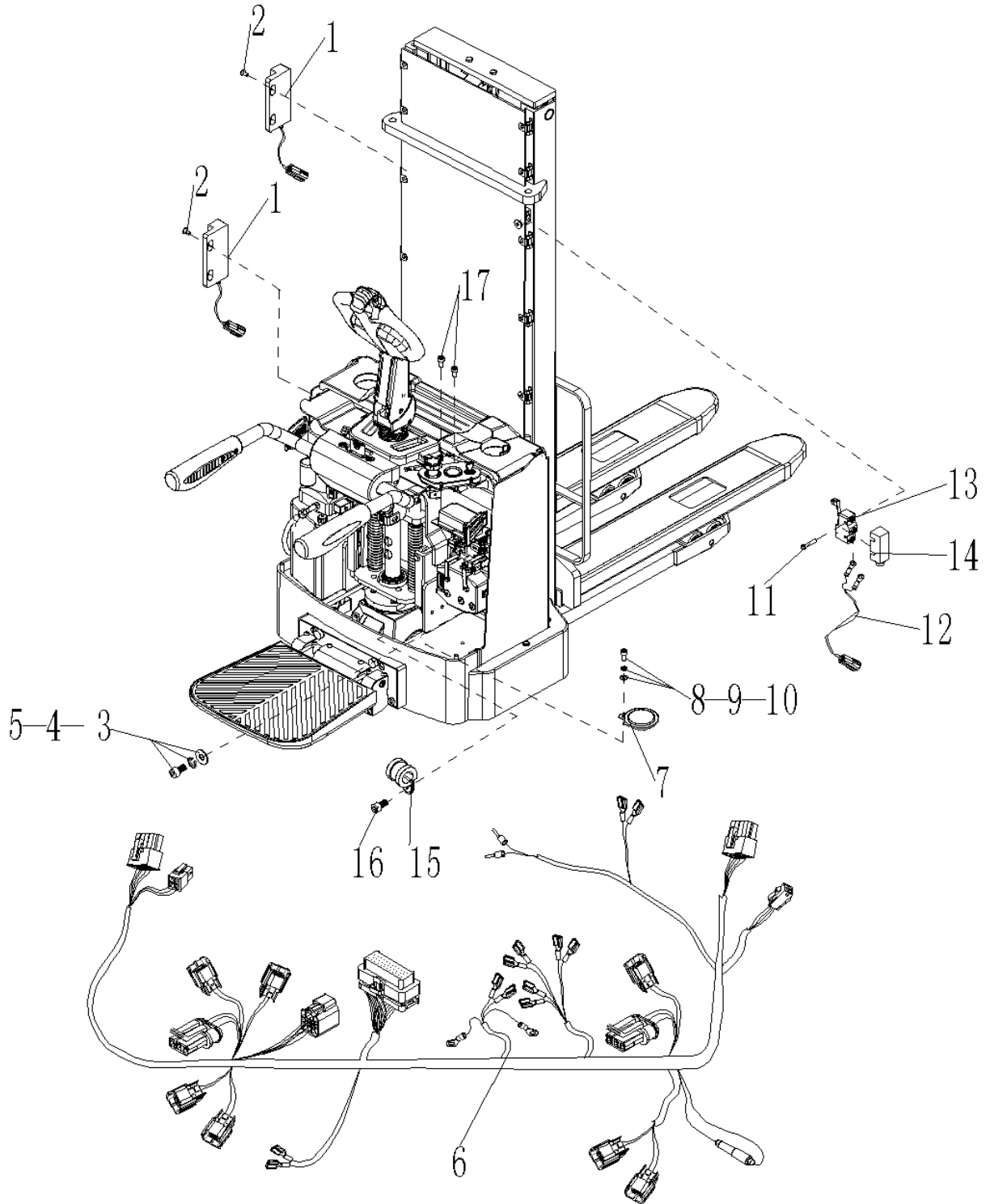

Fig. 16 Main Harness(electrical steering)

No.	Art No.	Description	Qty.	Note	Standard
1	900008429	Drive motor cable	1		
2	900008430	Pump motor cable	1		
3	900008431	Power supply cable	1		
4	900008432	FU+ cable	1		
5	900008433	Steering controller cable	1		
6	900008434	Steering motor cable	1		



Fig. 17 Electric parts(manual steering)



**Fig.17 Electric parts(manual steering)**

No.	Art No.	Description	Qty.	Note	Standard
1	9000008332	Magnet switch	2	HWK23	
2	0000023083	Screw	4	M3×8	GB/T70.2=ISO7380
3	0000023044	Screw	4	M8×20	GB/T70.1=ISO4762
4	0000025001	Washer	4	8	GB/T93
5	0000025011	Washer	4	8	GB/T97.1
6	9000008403	Main control wiring diagram	1		
7	1000434015	Horn	1	DC24V	
8	0000023478	Screw	1	M6×12	GB/T70.1=ISO4762
9	0000025010	Washer	1	6	GB/T93
10	0000023055	Washer	1	6	GB/T97.1
11	0000023033	Screw	2	M4×25	GB/T70.1=ISO4762
12	9000008404	Limit control wiring harness	1		
13	2040634001	Micro switch	1	XZ-15GW22-B	
14	2040603002	Micro switch cover	1		
15	9000009545	YGE hose clamp	1	26X20	
16	0000023042	Screw	1	M6×10	GB/T70.1=ISO4762
17	0000023106	Screw	2	M6×30	GB/T70.1=ISO4762

Fig. 18 Electric parts(electrical steering)

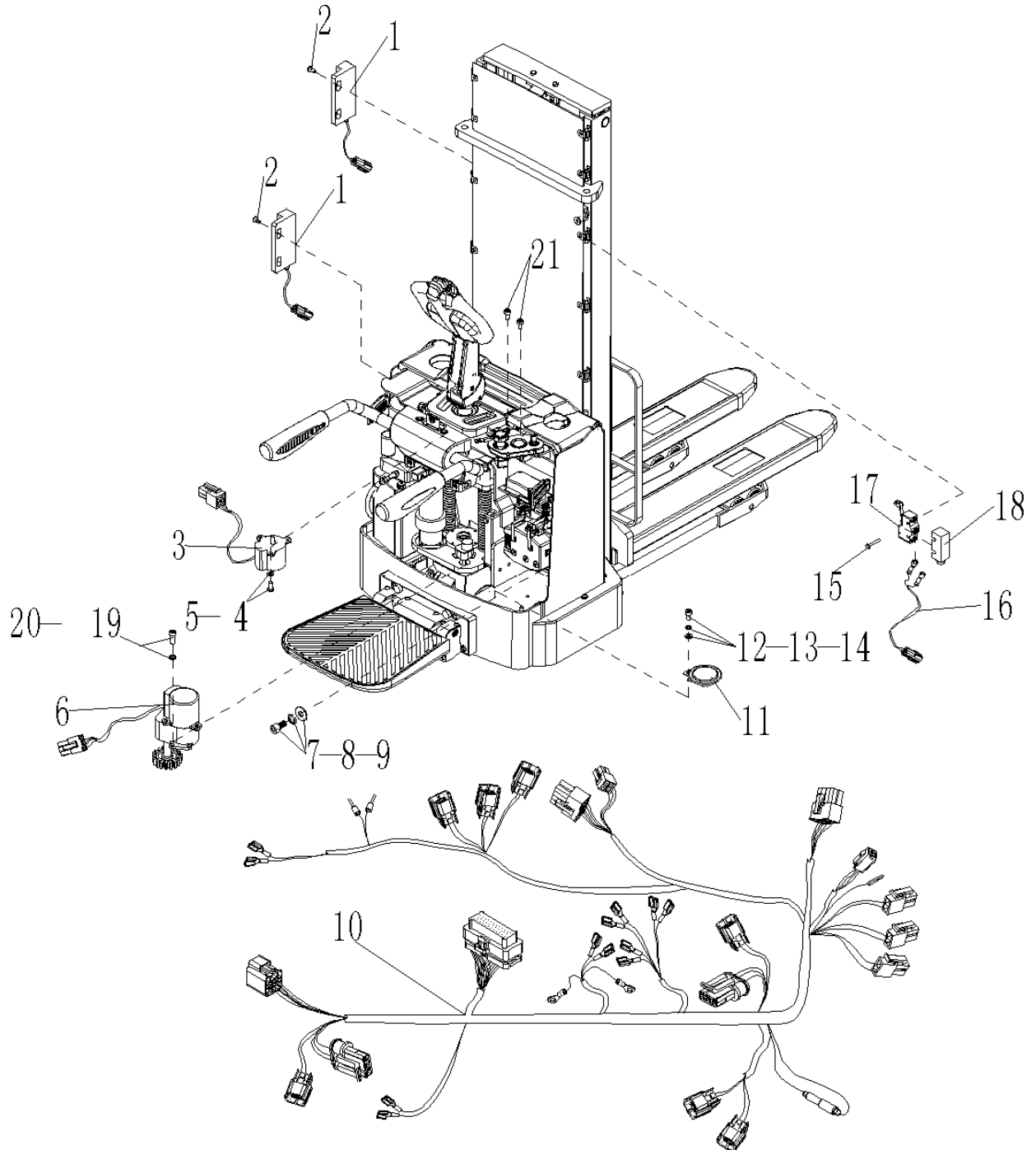

**Fig.18 Electric parts(electrical steering)**

No.	Art No.	Description	Qty.	Note	Standard
1	0000023083	Screw	4	M3x8	GB/T70.2=ISO7380
2	9000008332	Magnet switch	2	HWK23	
3	9000000239	Tiller sensor	1	BD-MS	
	9000008448			BD-MS-3	
4	0000025026	Washer	3	3	GB/T97.1
5	0000023216	Screw	3	M3×8	GB/T70.1=ISO4762
6	9000007132	Position sensor	1	BD-PS	
	9000008450			BD-PS-3	
7	0000023044	Screw	4	M8×20	GB/T70.1=ISO4762
8	0000025001	Washer	4	8	GB/T93
9	0000025011	Washer	4	8	GB/T97.1
10	9000008427	Main control wiring diagram	1		
11	1000434015	Horn	1	DC24V	
12	0000023478	Screw	1	M6×12	GB/T70.1=ISO4762
13	0000025010	Washer	1	6	GB/T93
14	0000023055	Washer	1	6	GB/T97.1
15	0000023033	Screw	2	M4×25	GB/T70.1=ISO4762
16	9000008428	Limit control wiring harness			
17	2040634001	Micro switch	1	XZ-15GW22-B	
18	2040603002	Limit switch protective cover	1		
19	0000023041	Screw	4	M4×30	GB/T818=ISO7045
20	0000025019	Washer	4	8	GB/T97.1
21	0000023106	Screw	2	M6×30	GB/T70.1=ISO4762

Fig. 19 Power supply

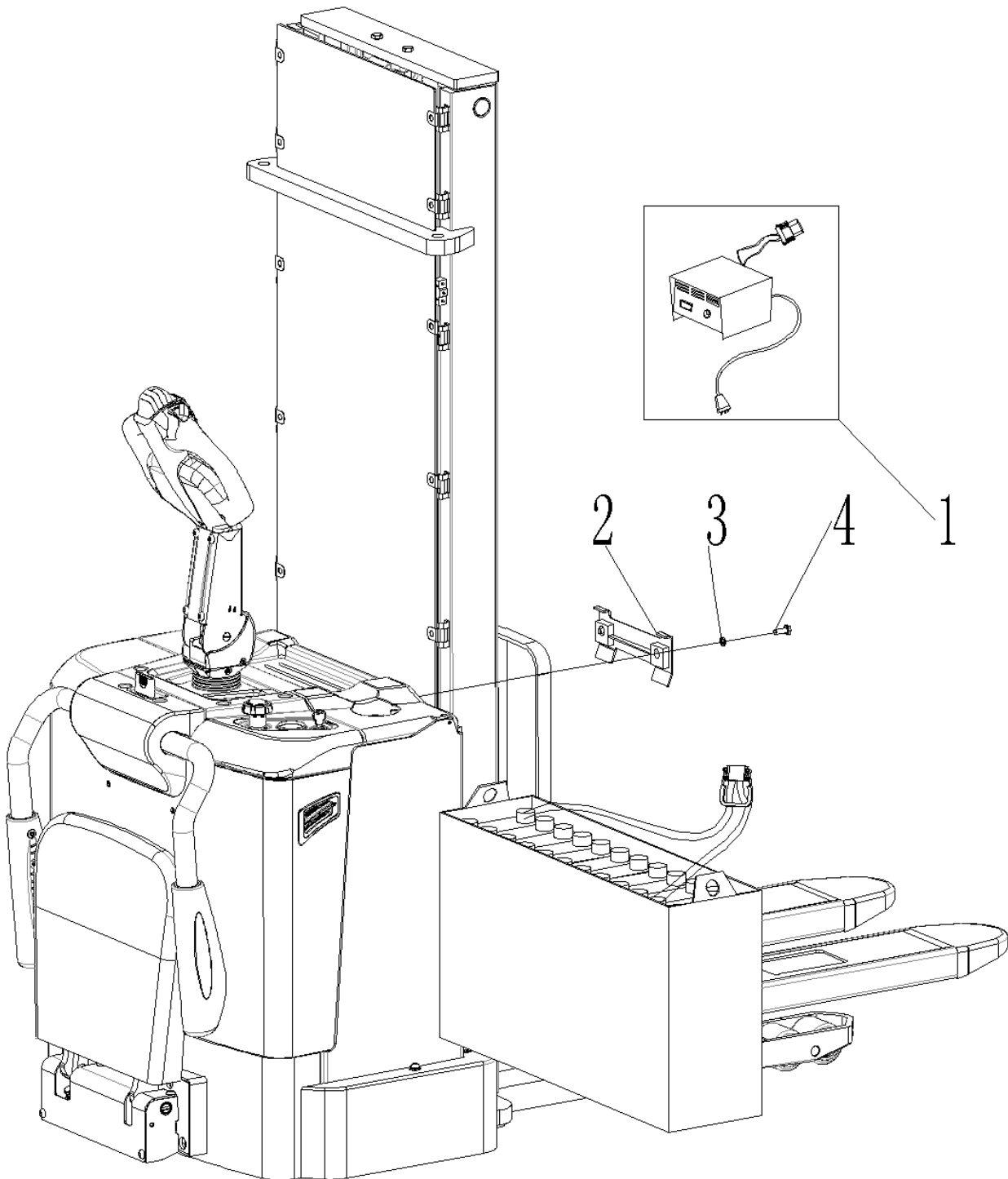

**Fig. 19 Power supply**

No.	Art No.	Description	Qty.	Note	Standard
1	9000010116	Charger	1	Asia in Chinese	
	9000010117			Asia in English	
	9000010118			For EU	
	9000010120			For AUS	
	9000010121			For UK	
	9000010146			For USA	
2	9000008083	Welded battery limit	1		
3	0000025004	Washer	2	8	GB/T93
4	0000023250	Bolt	2	M8x30	GB/T5783

Fig. 20 Battery

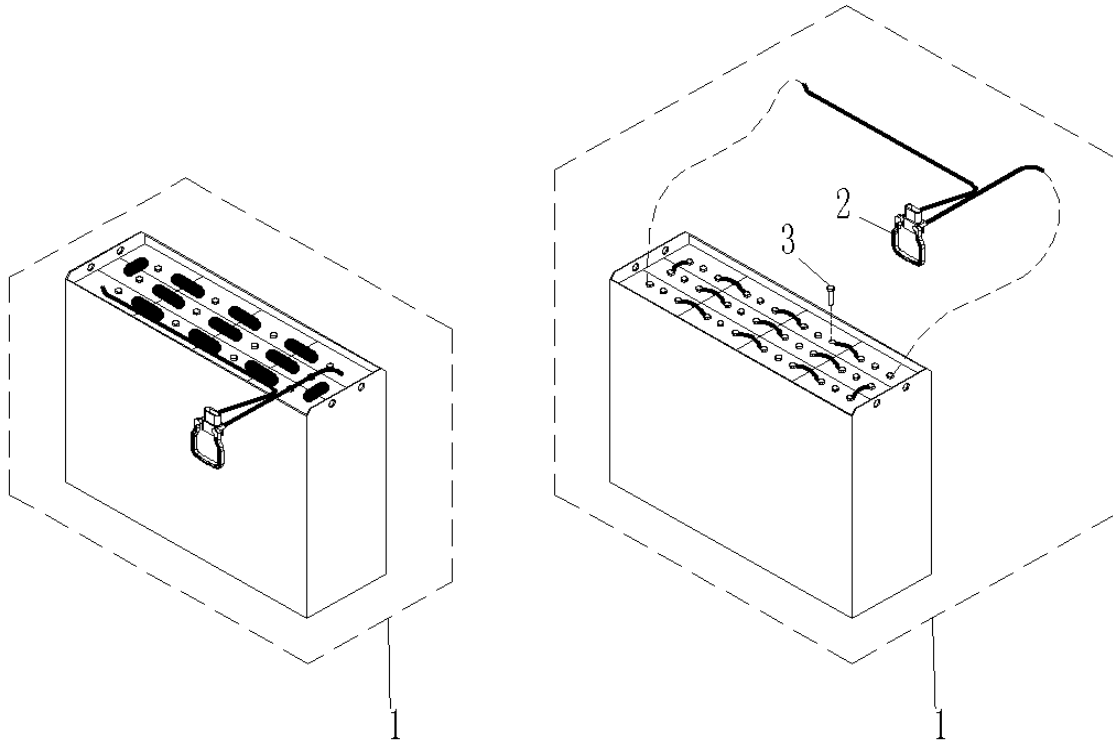

Fig. 20 Battery

No.	Art No.	Description	Qty.	Note	Standard
1	9000008157	Battery	1	Weld type	
	9000009995			Bolt type	
2	9000009997	Connector components	1	Only for bolt type battery	
3	9000009832	Screw	24	Only for bolt type battery	

Fig. 21 Hydraulic system(PS B15D Two-stage mast Lift)

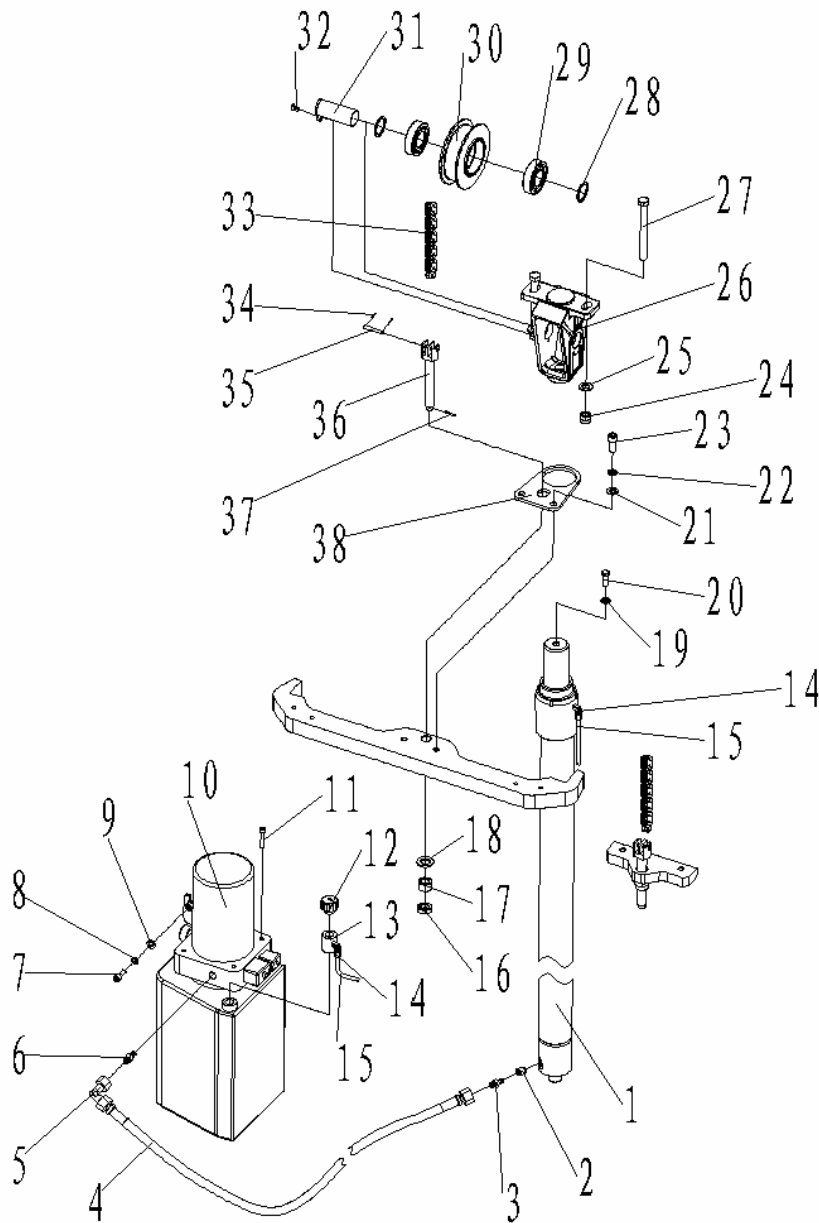

Fig. 21 Hydraulic system(PS B15D Two-stage mast Lift)

No.	Art No.	Description	Qty.	Note	Standard
1	9000008960	Piston rod	1	2900	
2	2000337001	Safety valve components	1		
3	9000007842	Straight joint	1		
4	9000007259	Tube	1		
5	9000007838	Steering connecting joint	1		
6	9000007832	G straight joint	1		



7	0000023067	Screw	2	M8x16	GB/T70.1=ISO4762
8	0000025001	Washer	2	8	GB/T93
9	0000025011	Washer	2	8	GB/T95
10	9000008867	DC power unit	1	24V3.0KW	
11	0000023090	Screw	4	M6×35	GB/T70.1=ISO4762
12	2000303001	Vent plug	1		
13	2010317003	Joint	1		
14	2010317001	Angle	2		
15	9000008140	Oil return tube	1		
16	0000024014	Nut	2	M16×1.5	GB/T6173 =ISO8675
17	0090000442	Nut	2	M16×1.5	GB/T6171
18	0000025029	Washer	2	16	GB/T95
19	0000025024	Washer	1	12	GB/T93
20	0000023094	Screw	1	M12×30	GB/T70.1=ISO4762
21	0090000047	Washer	2	10	GB/T97.1
22	0000023006	Washer	2	10	GB/T93
23	0000023088	Screw	2	M10×25	GB/T70.1=ISO4762
24	0000024006	Nut	2	M12	GB/T889.1=ISO7040
25	0000025032	Washer	2	12	GB/T95
26	2010305001	Chain wheel frame	1		
27	0000023209	Bolt	2	M12×130	GB/T5780
28	2000302002	Adjusting washer	2		
29	0000027012	Bearing	2	6206	GB/T276=ISO3290
30	2010310001	Chain wheel	1		
31	2030301001	Chain wheel axle components	1		
32	0000023091	Screw	1	M6×12	GB/T70.3
33	0000029012	Chain	1	2900	GB/T6074
34	0000028111	Split pin	4	1.6×10	GB/T91
35	0000028110	Pin roll	2	6×40	GB/T880
36	9000008983	Chain pulling bar	2		
37	0000028011	Split pin	2	3×40	GB/T91
38	2010302001	Fixing plate	1		

Fig. 22 Cylinder(PS B15D Two-stage mast Lift)

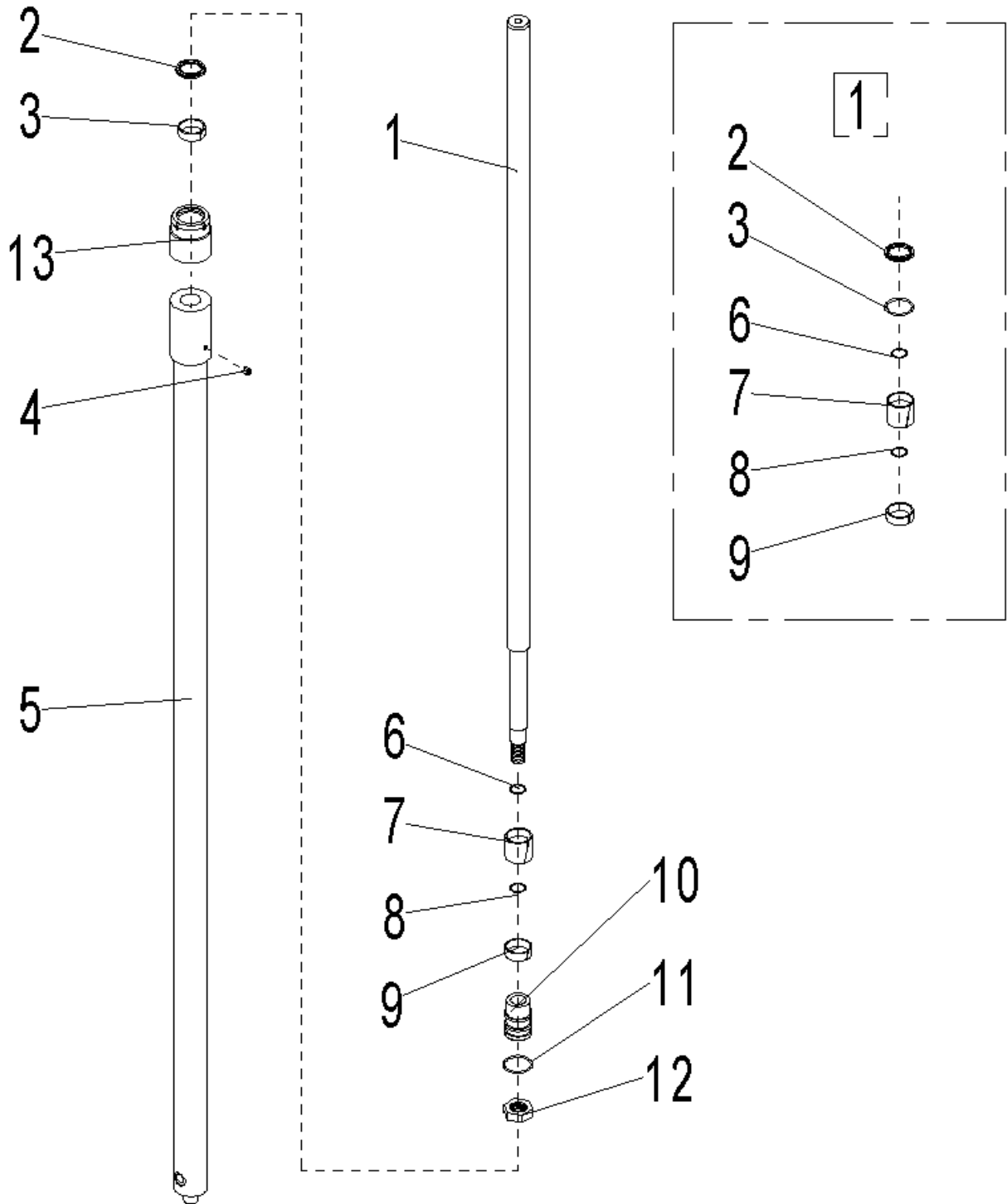

**Fig. 22 Cylinder(PS B15D Two-stage mast Lift)**

No.	Art No.	Description	Qty.	Note	Standard
1	9000009922	Piston rod	1	2900	
2	9000009926	Dust ring	1	40x48x5/6.5	
3	9000009927	Support ring for shaft	1	40X44X10	
4	0090000120	Vent plug	1	R1/8	JB/ZQ4446
5	9000009928	Cylinder body	1	2900	
6	9000009932	O ring	1	44.4X3.1	
7	9000009933	Support ring for hole	1	45X50X10	
8	9000009934	O ring	2	24.4X3.1	
9	9000009178	Y ring for hole	1	40X50X6/7	
10	9000009935	Piston	1		
11	0000025100	Washer	1	24	GB/T93
12	0000024072	Nut	1	M24x1.5	GB/T6171
13	9000009936	Cover	1		
①	9000009943	Cylinder seal kit	1		

Fig. 23 Hydraulic system(PS B15F Two-stage mast Full-Free-Lift)

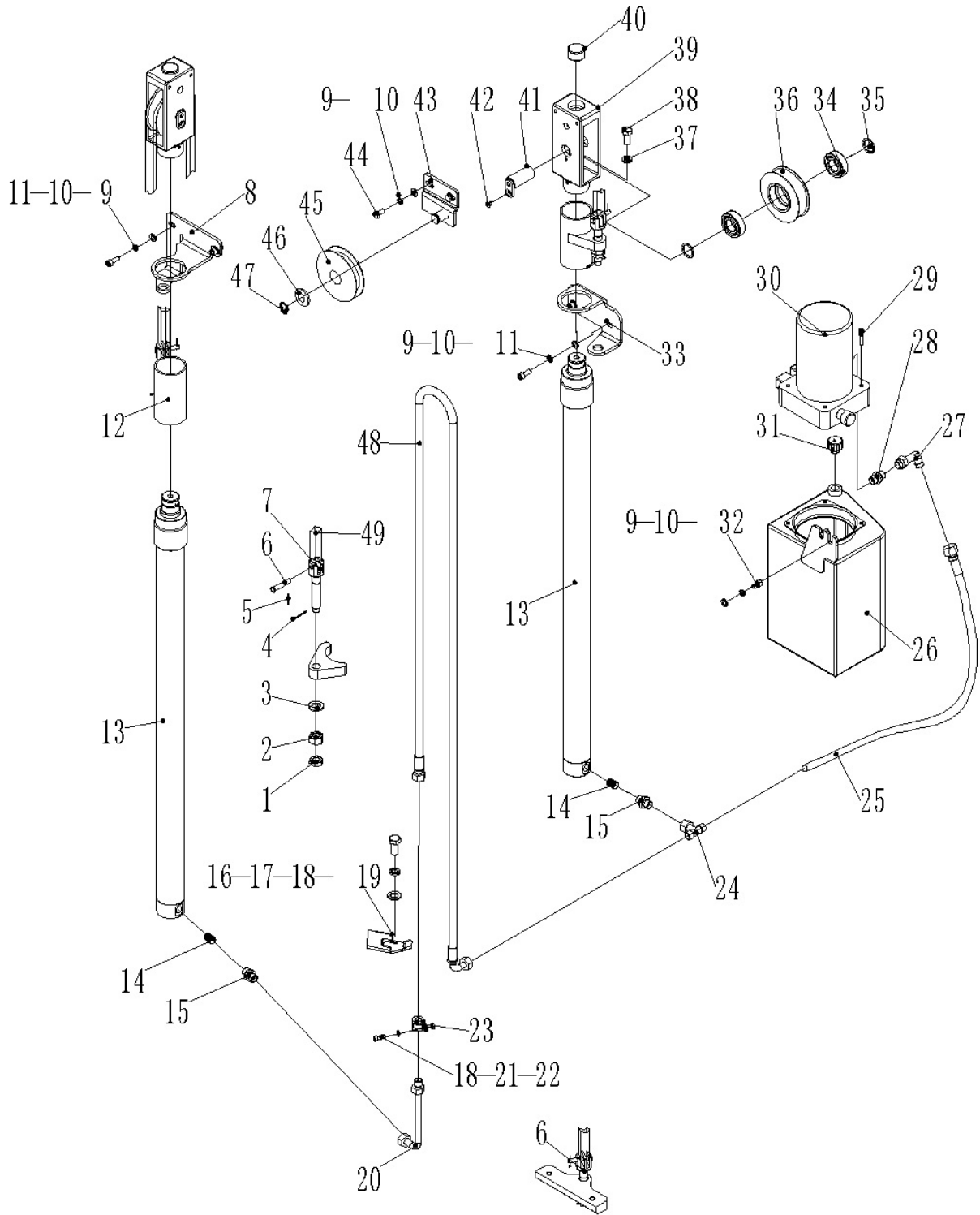

**Fig. 23 Hydraulic System(PS B15F Two-stage mast Full-Free-Lift)**

No.	Art No.	Description	Qty.	Note	Standard
1	0000024010	Nut	4	M16	GB/T6172.1
2	0000024184	Nut	4	M16	GB/T6170
3	0000025029	Washer	4	16	GB/T95
4	0000028011	Split pin	4	3×40	GB/T91
5	0000028010	Split pin	4	2×20	GB/T91
6	0000028060	Pin roll	4	8×35	GB/T882
7	9000009005	Chain pulling rod	4		
8	9000009003	Cylinder fixing plate	1		
9	0000025005	Washer	4	8	GB/T95
10	0000025004	Washer	4	8	GB/T93
11	0000023146	Screw	4	M8×16	GB/T70.1=ISO4762
12	2010301001	Pulling rod block	2		
13	9000008992	Cylinder	2	2900	
14	2000337001	Safety valve components	2		
15	9000007842	Straight joint	2		
16	2000302005	Tube board	1		
17	0000023845	Screw	2	M6×10	GB/T70.1=ISO4762
18	0000025006	Washer	1	6	GB/T93
19	0000025007	Washer	2	6	GB/T95
20	9000009004	Steel pipe	1		
21	0000023040	Screw	1	M6×16	GB/T70.1=ISO4762
22	0000024061	Nut	1	M6	GB/T6172.1
23	9000008325	YGE hose clamp	1		
24	9000008887	Steering connecting joint	1		
25	9000007259	Tube	1		
26	9000008141	Welded cylinder	1		
27	9000007838	Steering connecting joint	1		
28	9000007832	Straight joint	1		
29	0000023090	Screw	4	M6×35	GB/T70.1=ISO4762
30	9000008867	DC power unit	1	24V3.0KW	
31	2000303001	Vent plug	1		
32	0000023089	Screw	2	M8×12	GB/T70.1=ISO4762

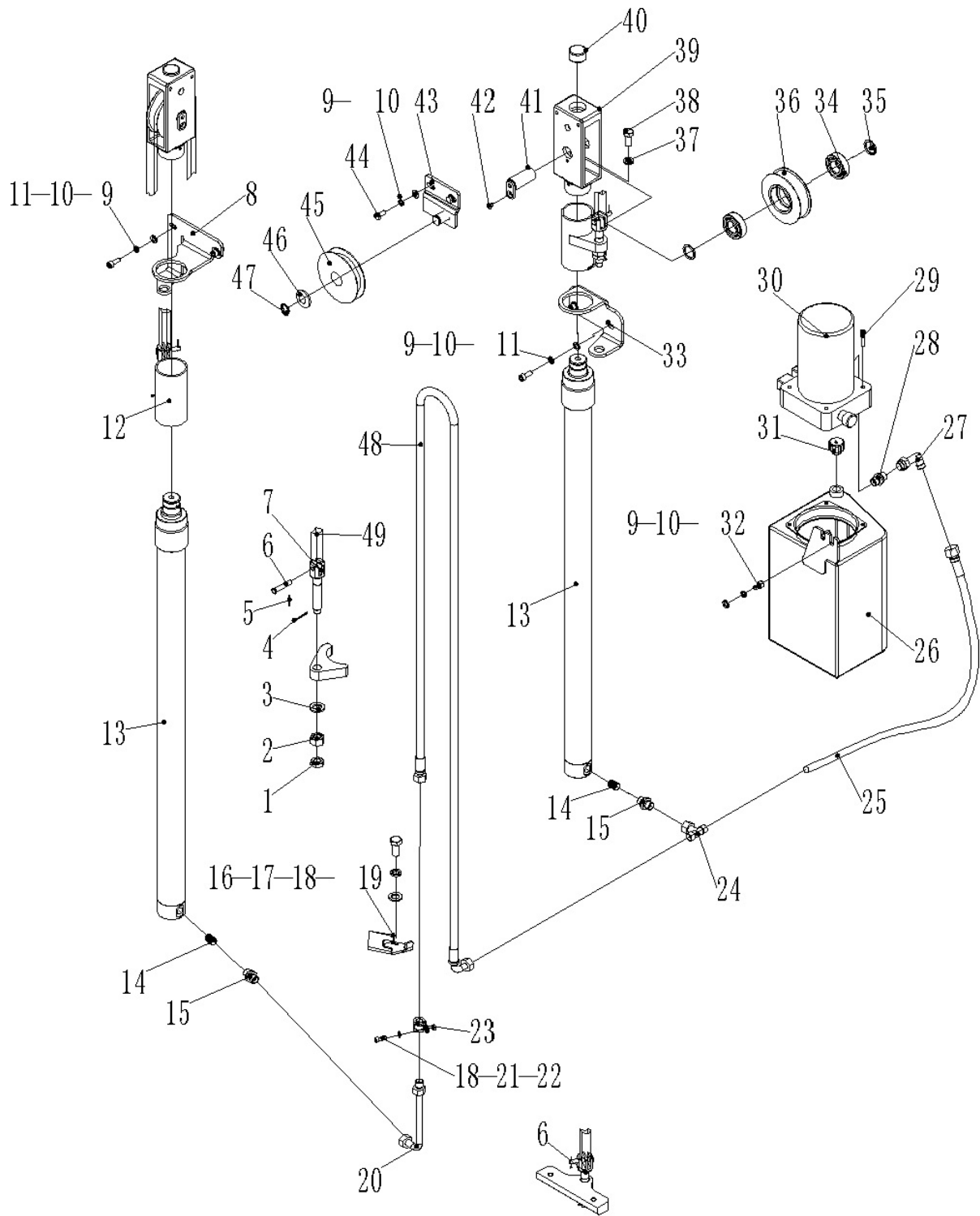

**Fig. 23 Hydraulic System(PS B15F Two-stage mast Full-Free-Lift)**

33	9000009002	Frame 1	1		
34	0000027012	Bearing	4		GB/T276-1994
35	2000302002	Adjusting washer	4		
36	2010310001	Chain wheel	2		
37	0000025024	Washer	2	12	GB/T93
38	0000023226	Bolt	2	M12×25	GB/T5783
39	2010305001	Chain frame	2		
40	2010319001	Damping pad	2		
41	2030301001	Pin components	2		
42	0000023557	Screw	2	M6×10	GB/T70.3
43	2000301002	Welded pulley frame	1		
44	0000023230	Bolt	2	M8×16	GB/T5783
45	2000310002	Pulley	1		
46	0000025092	Washer	1	20	GB/T97.2
47	0000026003	Circlip	1	20	GB/T894.1
48	9000008888	90° Tube	1	2900	
49	0090000484	Chain LH1244×61	2	2900	GB/T6074

Fig. 24 Cylinder(PS B15F Two-stage mast Full-Free-Lift)

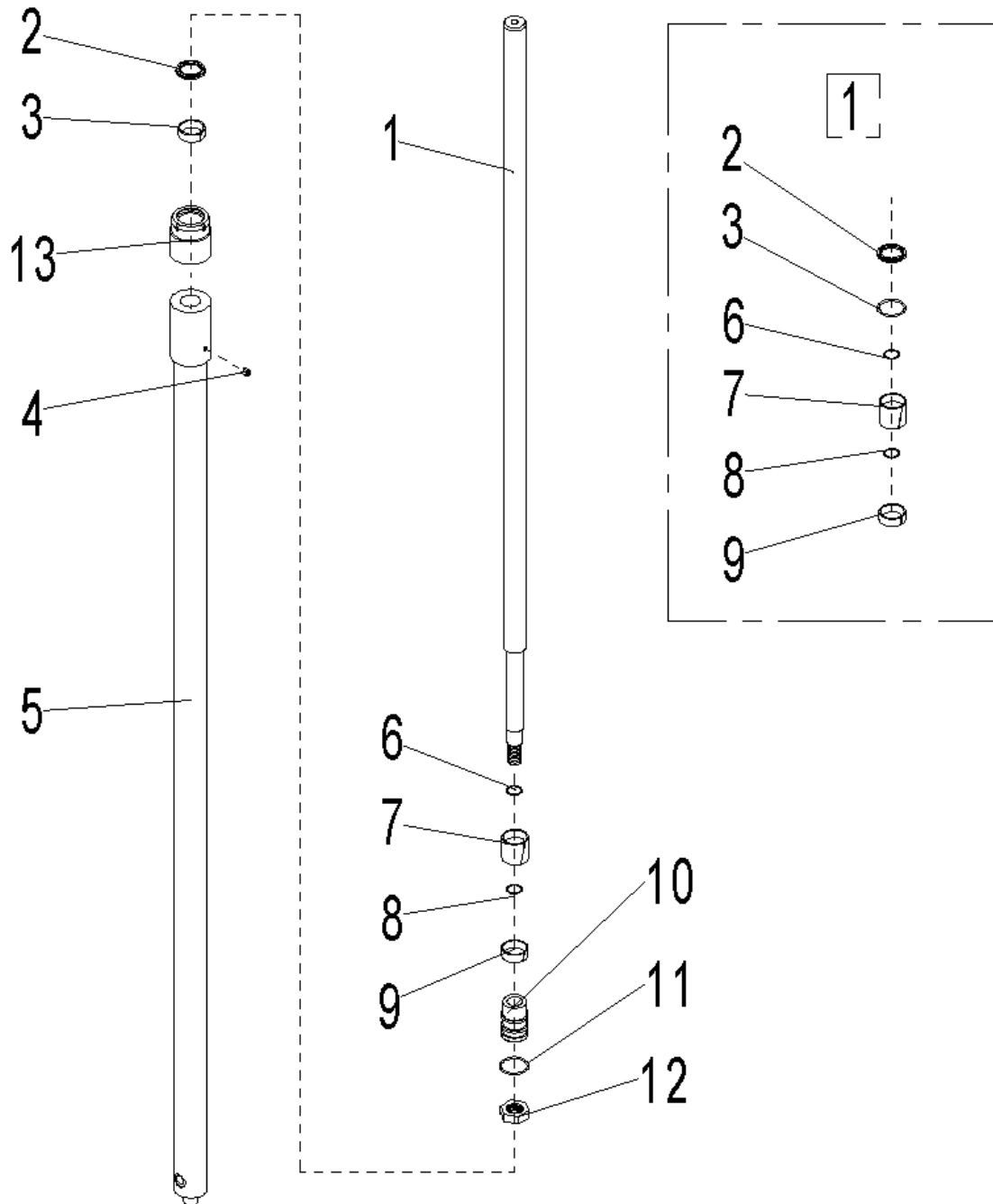



**Fig. 24 Cylinder(PS B15F Two-stage mast Full-Free- Lift)**

No.	Art No.	Description	Qty.	Note	Standard
1	9000009937	Piston rod	1	2900	
2	9000009926	Dust ring	1	40x48x5/6.5	
3	9000009927	Support ring for shaft	1	40X44X10	
4	0090000120	Vent plug	1	R1/8	JB/ZQ4446
5	9000009939	Cylinder body	1	2900	
6	9000009932	O ring	1	44.4X3.1	
7	9000009933	Support ring for hole	1	45X50X10	
8	9000009934	O ring	2	24.4X3.1	
9	9000009178	Y ring for hole	1	40X50X6/7	
10	9000009941	Piston	1		
11	0000025033	Washer	1	20	GB/T93
12	0000024074	Nut	1	M20x1.5	GB/T6171
13	9000009942	Guide bushing	1		
①	9000009944	Cylinder seal kit	1		

Fig. 25 Hydraulic system(PS B15H Three-stage mast Lift)

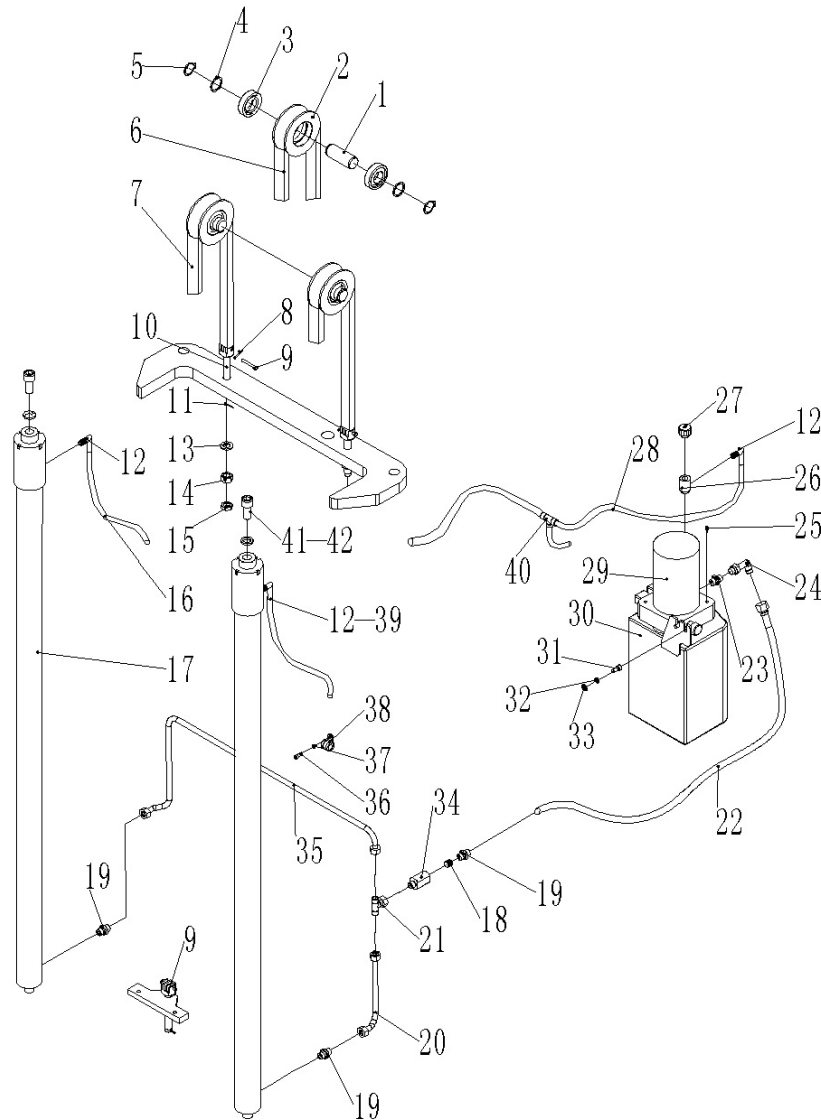
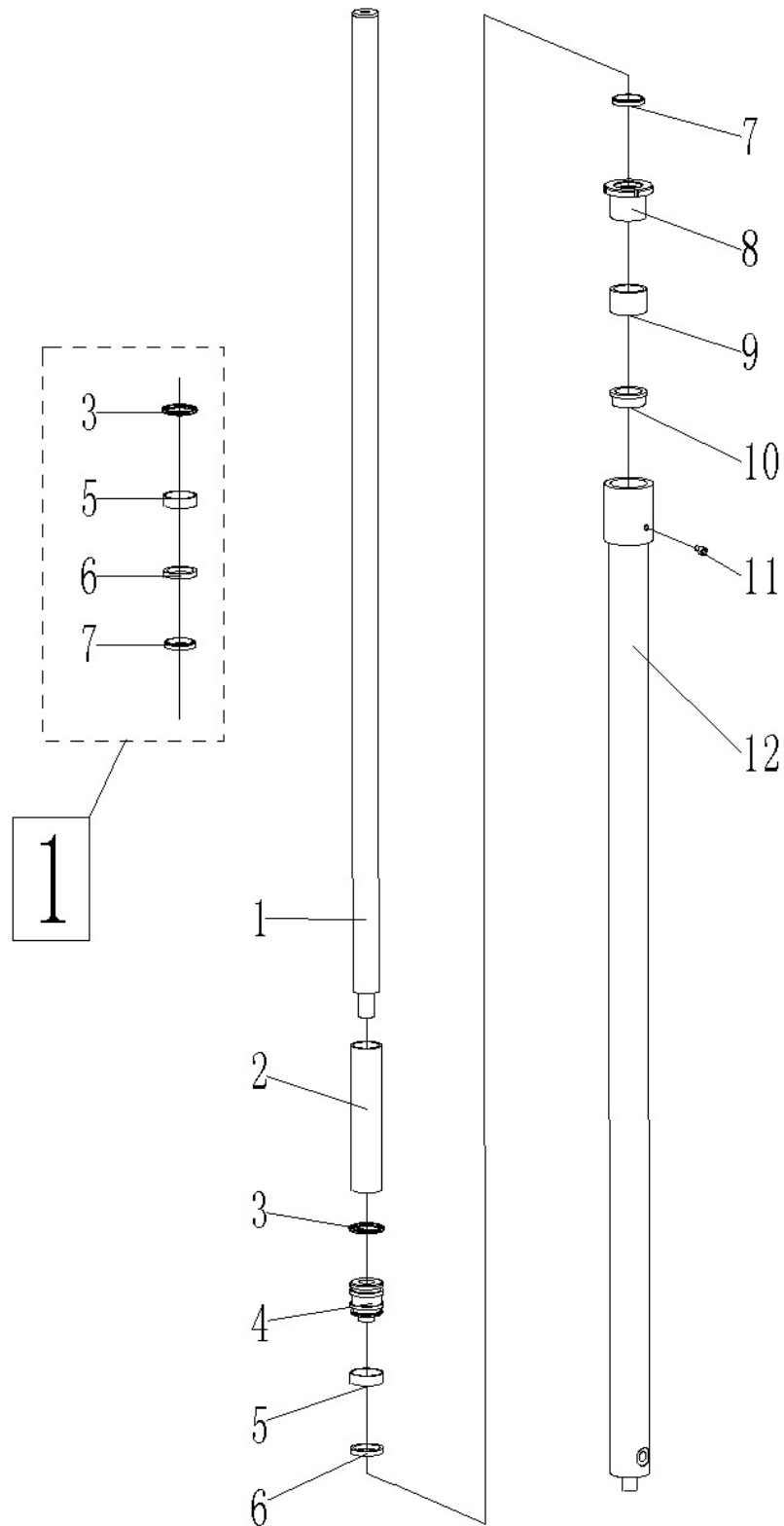

Fig. 25 Hydraulic System(PS B15H Three-stage mast Lift)

No.	Art No.	Description	Qty.	Note	Standard
1	9000009119	Chain wheel shaft	3		
2	2390302024	Chain wheel for mast	3		
3	0000027012	Bearing	6		GB/T276=ISO3290
4	2000302002	Adjusting washer	6		
5	0000026008	Circlip	6	30	GB/T894.1
6	0000029066	Chain LH1066	1	101	GB/T6074
7	0000029085	Chain LH1066	2	97	GB/T6074
8	0000028010	Split pin	6	2×20	GB/T91

9	0000028017	Pin roll	6	6×35	GB/T882
10	9000008260	Bolt	3		
11	0000028104	Split pin	3	2.5×25	GB/T91
12	2010317001	Angle	3		
13	0000025029	Washer	3	16	GB/T95
14	0090000442	Nut	3	M16×1.5	GB/T6171
15	0000024014	Nut	3	M16×1.5	GB/T6173
16	9000009114	Oil return tube	3		
17	9000009123	Cylinder	2		
18	2000337001	Safety valve components	1		
19	9000007842	Straight joint	3		
20	9000009113	Steel tube B	1		
21	9000008887	Steering connecting elbow	1		
22	9000007258	Tube	1		
23	9000007832	G straight joint	1		
24	9000007838	Steering connecting elbow	1		
25	0000023090	Screw	4	M6×35	GB/T70.1=ISO4762
26	2010317003	Joint	1		
27	2000303001	Cylinder cover	1		
28	9000009198	Oil return tube	1		
29	9000008867	DC power unit	1	24V3.0KW	
30	9000008141	Welded cylinder	1		
31	0000023067	Screw	2	M8×16	GB/T70.1=ISO4762
32	0000025001	Washer	2	8	GB/T93
33	0000025011	Washer	2	8	GB/T95
34	9000009120	Long joint	1		
35	9000009112	Steel tube A	1		
36	0000025010	Washer	1	6	GB/T93
37	0000023053	Screw	1	M6×12	GB/T70.1=ISO4762
38	9000008325	YGE hose clamp	1		
39	9000009115	Oil return tube	1		
40	2250317004	Joint	1		
41	0000025024	Washer	2	12	GB/T93
42	0000023156	Screw	3	M12×25	GB/T70.1=ISO4762

Fig. 26 Cylinder(PS B15H Three-stage mast Lift)



**Fig. 26 Cylinder(PS B15H Three-stage mast Lift)**

No.	Art No.	Description	Qty.	Note	Standard
1	9000009179	Piston rod	1	3400	
2	9000009180	Bushing	1		
3	0000022029	O ring	1	50×3.1	GB1235
4	9000009181	Piston	1		
5	9000009182	Support ring for hole	1	46×50×15	
6	9000009178	Y ring for hole	1	40×50×6/7	
7	9000009169	Dust ring	1	40×48×5/6.5	
8	9000009183	Cap nut	1		
9	9000009184	Bushing	1		
10	9000009185	Guide bushing	1		
11	0090000120	Vent plug	1	RC1/8	JB/ZQ4446
12	9000009186	Welded cylinder body	1	3400	
□	9000009956	Cylinder seal kit	1		

Fig. 27 Pump system

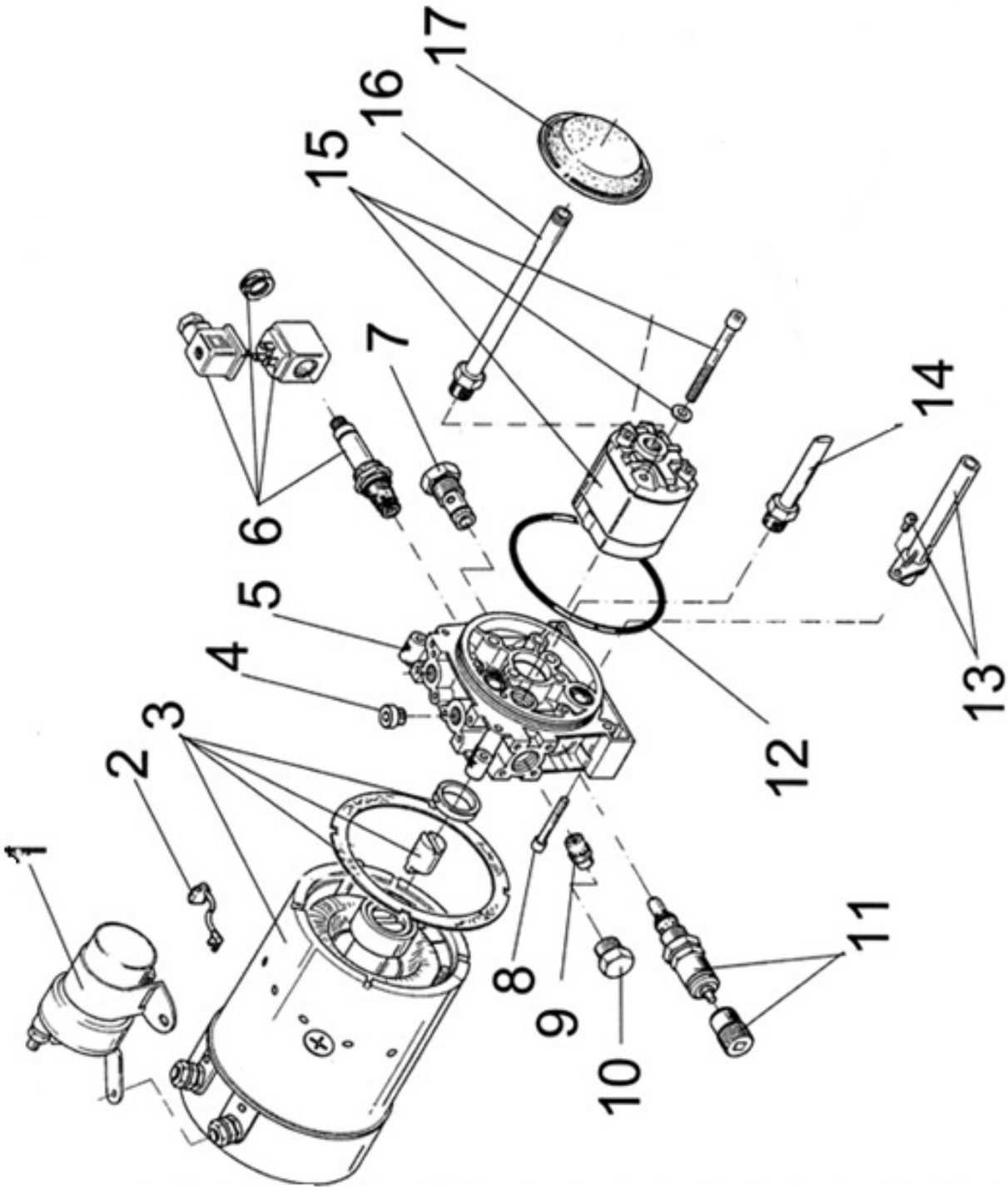

**Fig. 27 Pump system**

No.	Parts No.	Item	Qty.	Note	Standard
1	2040334001	Pump contactor	1		
2	9000003582	Carbon brush(components)	1		
3	9000003583	Motor	1		
4	2000323001	Plug	1		
5	2000300002	Valve	1		
6	2000335003	Solenoid valve	1		
7	2000335004	Check valve	1		
8	2000323002	Screw	4		
9	9000008870	Throttle valve	1	7.5L/min	
10	2000323003	Bolt	1		
11	2040315003	Overflow valve	1		
12	2000322004	O ring	1		
13	2000317008	Oil return tube	1		
14	2040317008	Oil return tube	1		
15	9000008874	Gear pump 3.2cc/r	1		
16	9000008873	Oil suction pipe	1	L=250.50mm	
17	2000300004	Filter	1		

Fig. 28 Hydraulic system(PS B15Z Three-stage mast Full-Free-Lift)

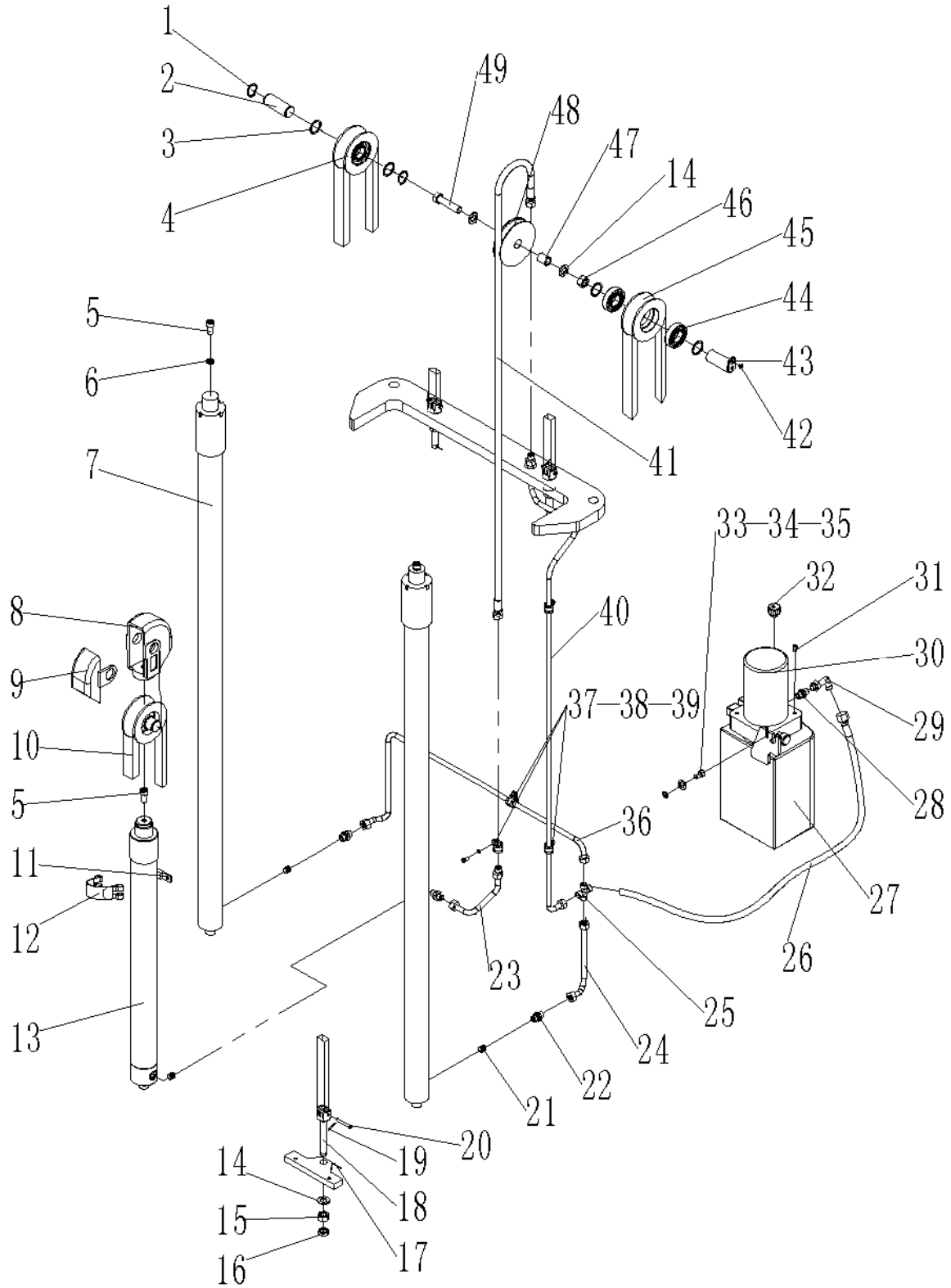



**Fig. 28 Hydraulic System(PS B15Z Three-stage mast Full-Free-Lift)**

No.	Art No.	Description	Qty.	Note	Standard
1	0000026008	Circlip	4	30	GB/T894.1
2	2230307001	Chain wheel shaft	1		
3	2000302002	Adjusting washer	6		
4	2390302024	Chain wheel for mast	3		
5	0000023156	Screw	3	M12×25	GB/T70.1=ISO4762
6	0000025024	Washer	2	12	GB/T93
7	9000009131	Cylinder	2	3400	
8	2230305001	Chain wheel block	1		
9	2230305002	Side cover	1		
10	0000029067	Chain LH1066	1	69	GB/T6074
11	9000008247	High pressure cylinder block	1		
12	9000007802	Embrace hoop components	1		
13	9000009126	Middle cylinder	1	3400	
14	0000025029	Washer	5	16	GB/T95
15	0090000442	Nut	3	M16×1.5	GB/T6171
16	0000024014	Nut	3	M16×1.5	GB/T6173
17	0000028104	Split pin	3	2.5×25	GB/T91
18	9000008260	Bolt	3		
19	0000028010	Split pin	6	2×20	GB/T91
20	0000028017	Pin roll	6	6×35	GB/T882
21	2000337001	Circlip	3		
22	9000007842	Chain wheel shaft	3		
23	9000009127	Steel tube A	1		
24	9000009128	Steel tube B	1		
25	9000007841	Joint	1		
26	9000007258	Tube	1		
27	9000008141	Cylinder	1		
28	9000007832	G straight joint	1		
29	9000007838	Steering connecting elbow	1		

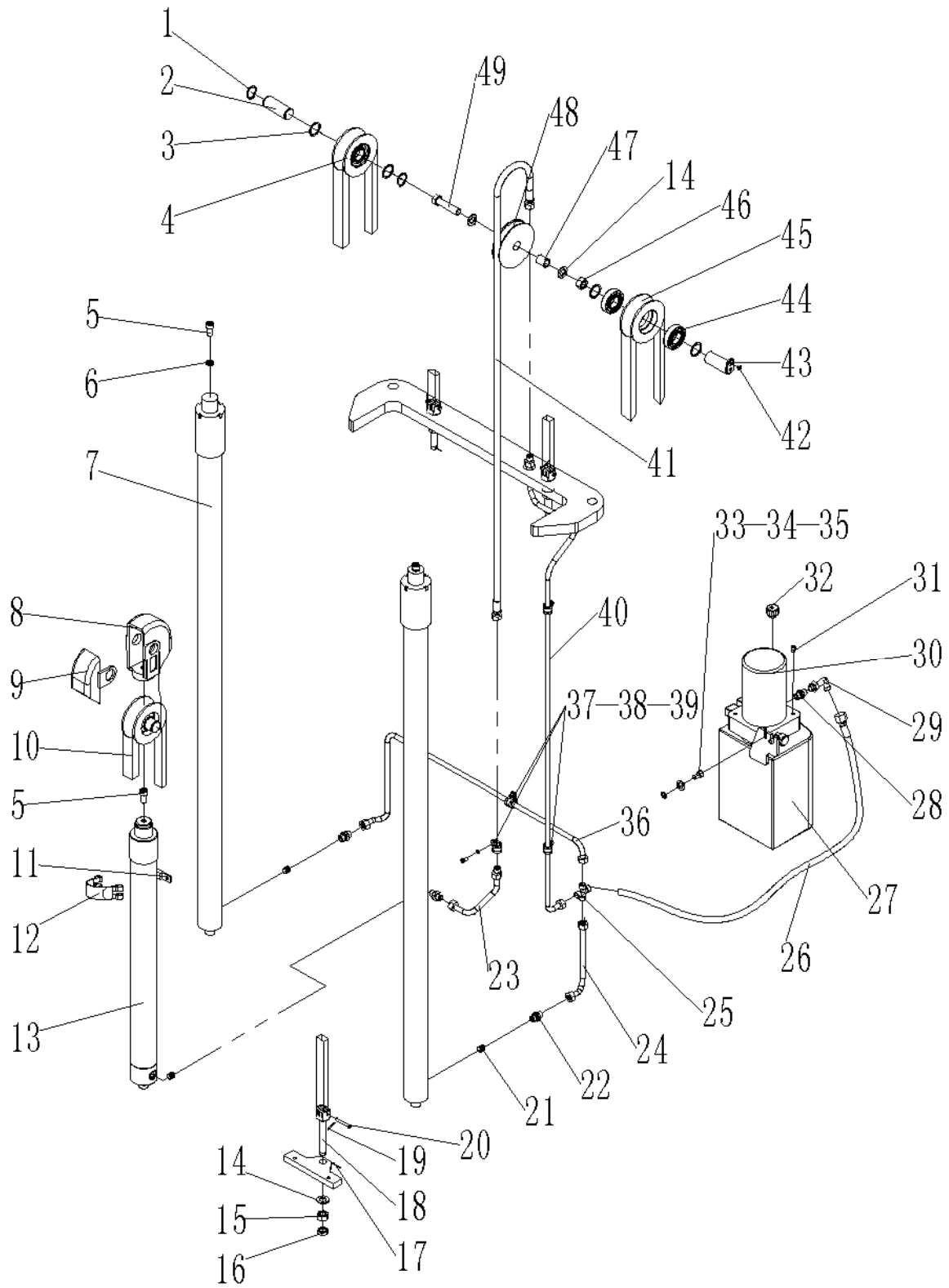

**Fig. 28 Hydraulic System(PS B15Z Three-stage mast Full-Free-Lift)**

30	9000008796	DC power unit	1	24V3.0KW high pressure	
31	0000023090	Screw	4	M6×35	GB/T70.1=ISO4762
32	2000303001	Cylinder cover	1		
33	0000023067	Screw	2	M8×16	GB/T70.1=ISO4762
34	0090000204	Washer	2	8	GB/T95
35	0000025004	Washer	2	8	GB/T93
36	9000009112	Steel tube A	1		
37	9000008325	YGE hose clamp	4		
38	0000023478	Screw	4	M6×12	GB/T70.1=ISO4762
39	0000025006	Washer	6	6	GB/T93
40	9000009129	Steel tube B	1		
41	9000007265	Tube	1		
42	0000023091	Screw	1	M6×12	GB/T70.3
43	9000009130	Chain wheel shaft	1		
44	0000027012	Bearing	6		GB/T276=ISO3290
45	0000029085	Chain LH1066	2	97	GB/T6074
46	0000024036	Nut	1	M16	GB/T6170
47	9000008245	Bearing sleeve	1		
48	9000008246	Pulley	1		
49	0000023810	Bolt	1	M16×70	GB/T5782

Fig. 29 Cylinder (PS B15Z Three-stage mast Full-Free-Lift)

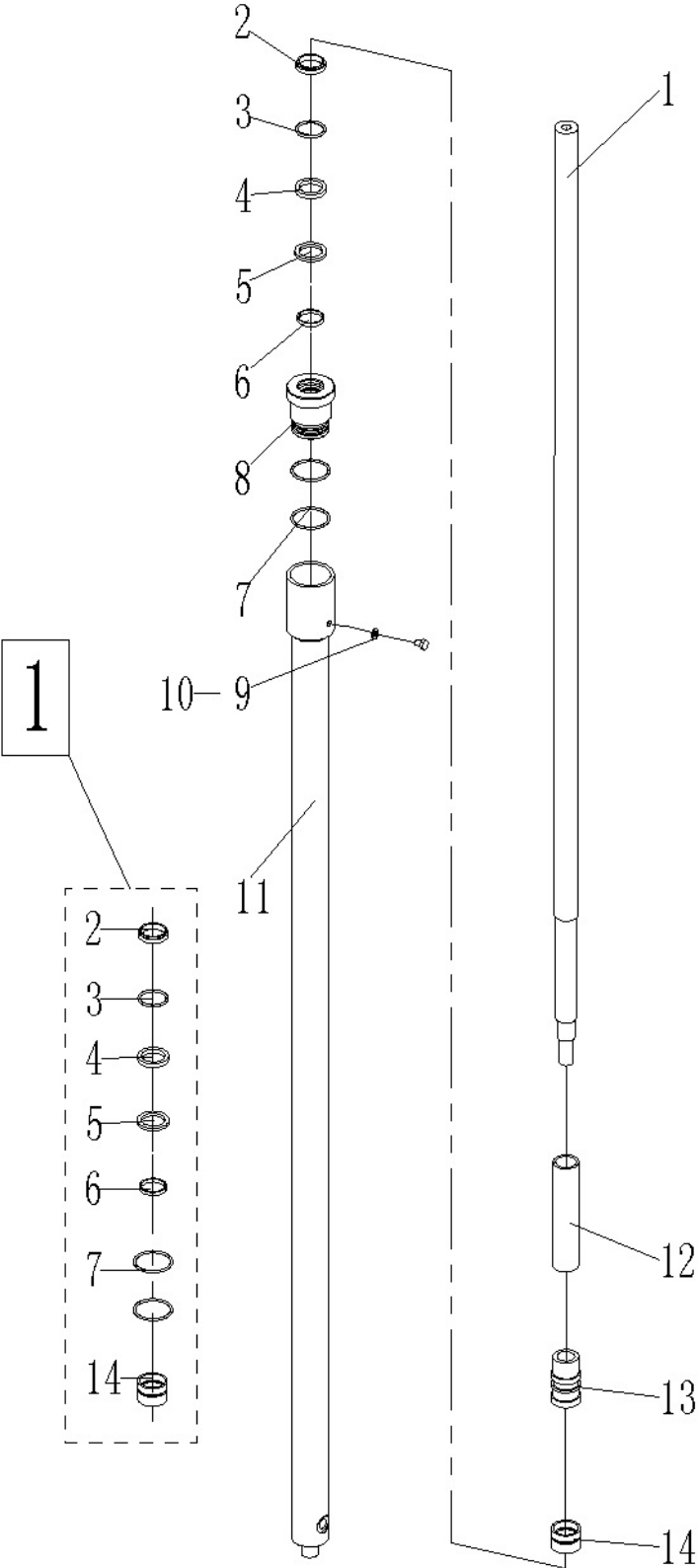

**Fig. 29 Cylinder (PS B15Z Three-stage mast Full-Free-Lift)**

No.	Art No.	Description	Qty.	Note	Standard
1	9000009219	Piston rod	1	3400	
2	9000009075	Dust ring	1	32X40X5/6.5	
3	0090000487	O ring	1	38X3.1	
4	9000009079	Seal ring for shaft	1	32X42X6/7	
5	9000008953	Seal ring	1	32X42.7X4.2	
6	9000008954	Support ring for shaft	1	32X36X5	
7	0000022029	O ring	2	50X3.1	
8	9000009220	Guide bushing	1		
9	0090000120	Vent plug	1	RC1/8	JB/ZQ4446
10	0000022026	Seal washer	1	8	JB/T982
11	9000009221	Cylinder body	1	3400	
12	9000009222	Bushing	1	3400	
13	9000009223	Piston	1		
14	9000008955	Support ring for hole	2	36X40X10	
□	9000009957	Cylinder seal kit	1		

Fig. 30 Middle cylinder(PS B15Z Three-stage mast Full-Free-Lift)

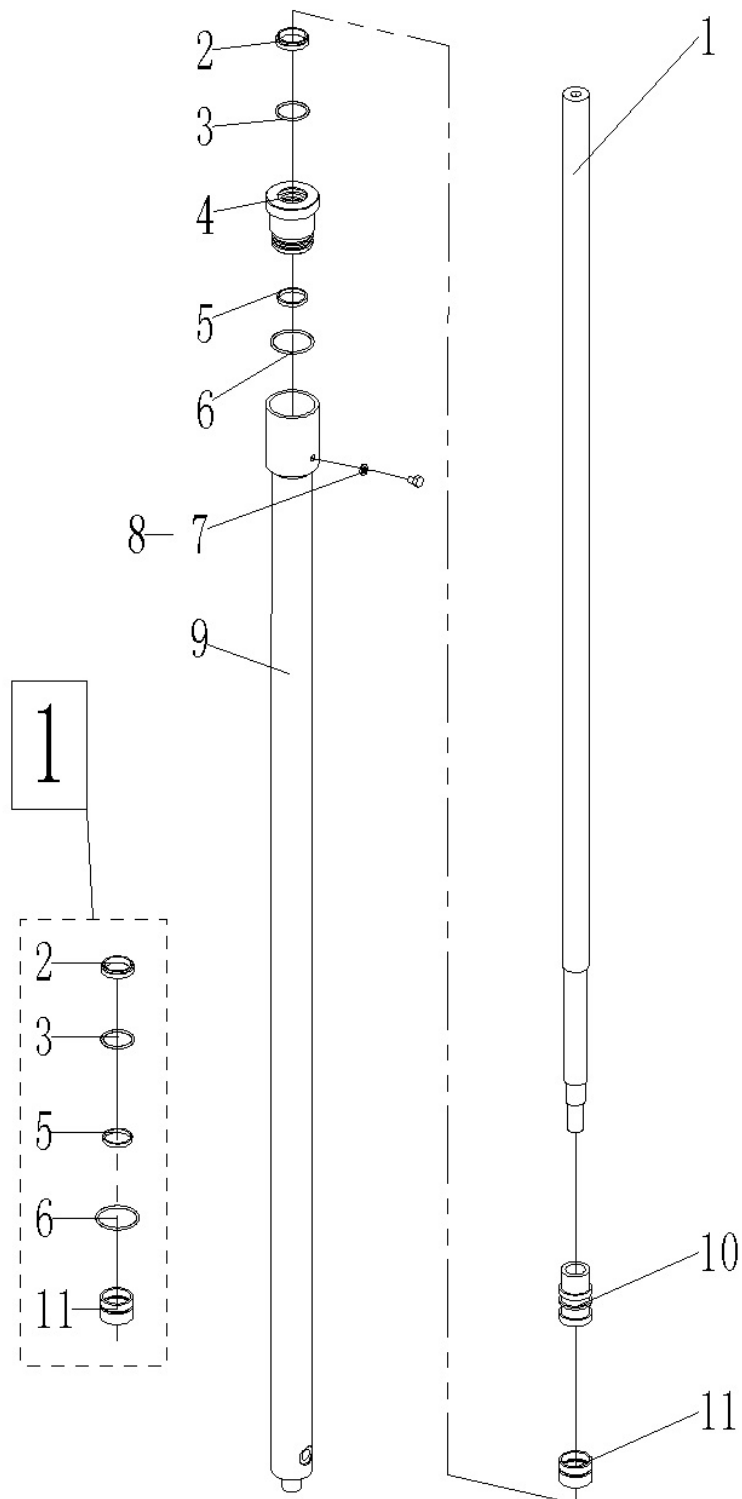

**Fig. 30 Middle cylinder(PS B15Z Three-stage mast Full-Free- Lift)**

No.	Art No.	Description	Qty.	Note	Standard
1	9000009224	Piston rod	1	3400	
2	9000009076	Dust ring	1	45X53X5/6.5	
3	9000009078	Seal ring for shaft	1	45X55X6/7	
4	9000009225	End cap	1		
5	9000008957	Circlip	1	55X60X1.5	
6	0000022055	O ring	1	60X3.1	GB1235
7	0000023415	Screw	1	M8X10	GB/T 70.1
8	9000009077	Copper bushing	1	45X50X30	
9	9000009226	Cylinder body	1	3400	
10	9000009227	Piston	1		
11	9000008956	Support ring for hole	1	48X52X15	
□	9000009958	Cylinder seal kit	1		

Fig. 31 Pump system(high pressure)

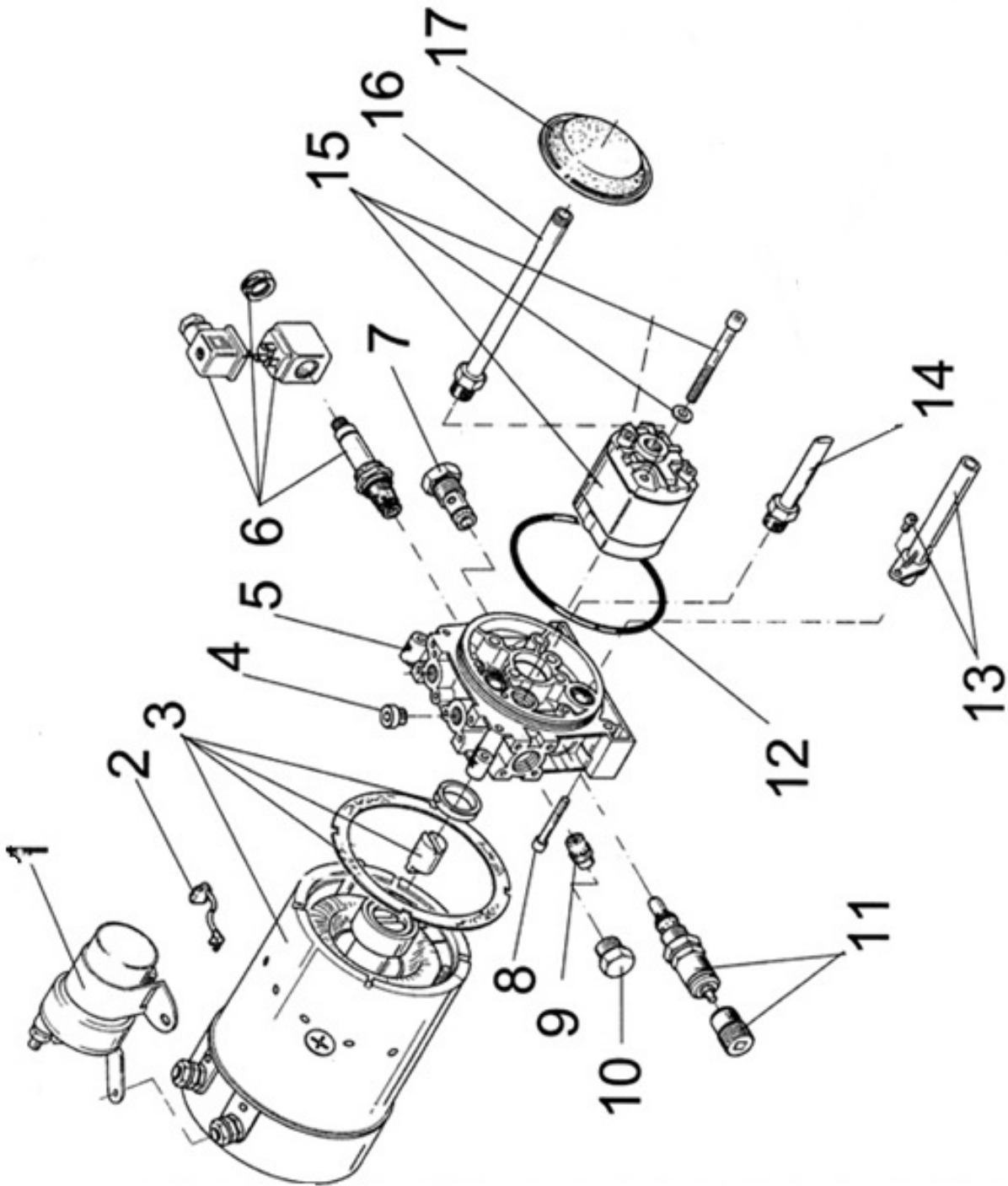



**Fig. 31 Pump system(high pressure)**

No.	Art No.	Description	Qty.	Note	Standard
1	2040334001	Pump contactor	1		
2	9000003582	Carbon brush (components)	1		
3	9000003583	Motor	1		
4	2000323001	Plug	1		
5	2000300002	Valve	1		
6	2000335003	Solenoid valve	1		
7	2000335004	Check valve	1		
8	2000323002	Screw	4		
9	9000008828	Throttle valve	1	9.5L/min	
10	2000323003	Bolt	1		
11	2040315003	Overflow valve	1		
12	2000322004	O ring	1		
13	2000317008	Oil return tube	1		
14	2040317008	Oil return tube	1		
15	9000008829	Gear pump	1	2.6 high pressure delivery capacity	
16	2040317009	Oil suction pipe	1		
17	2000300004	Filter	1		

Fig. 32 Drive system(manual steering)

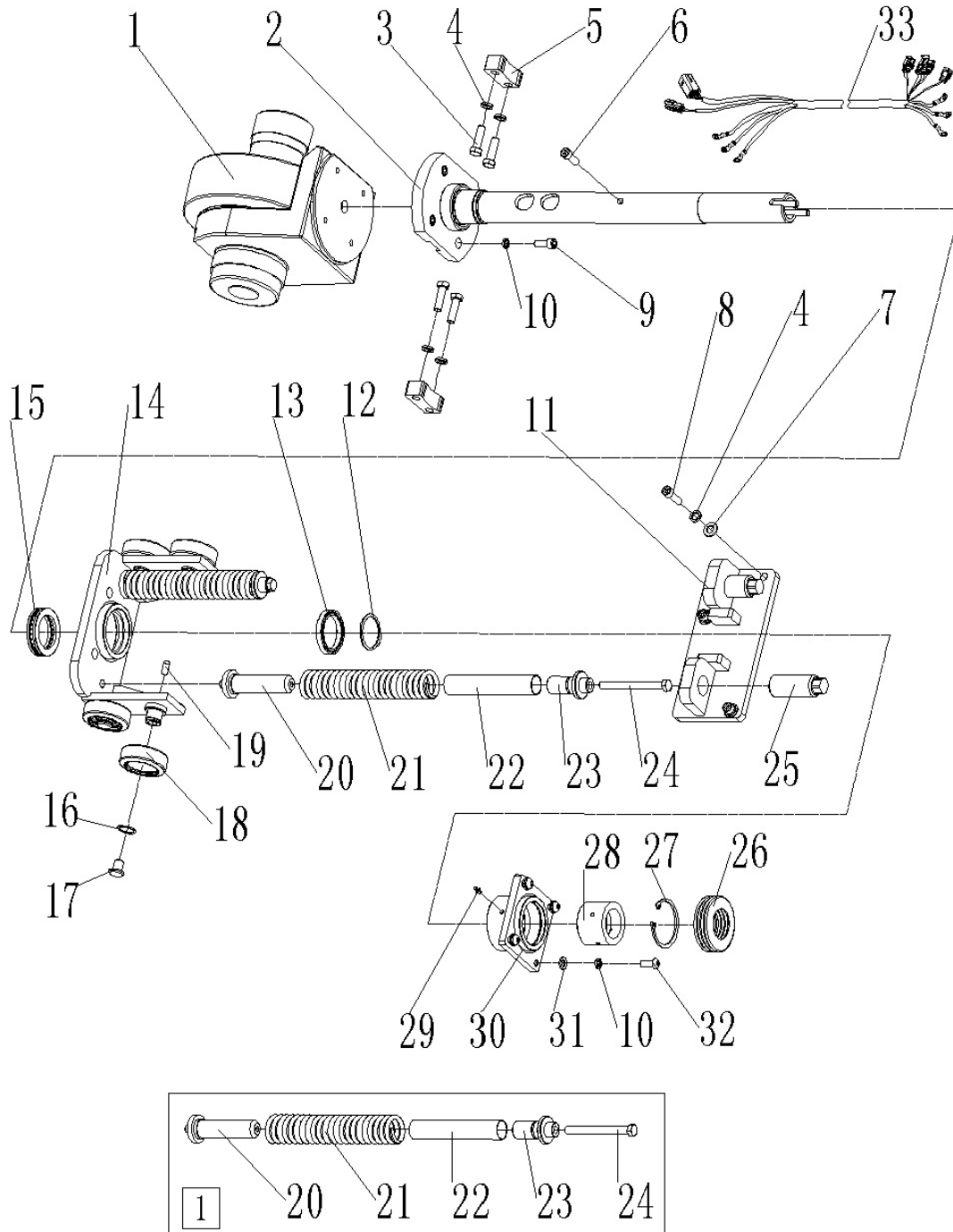
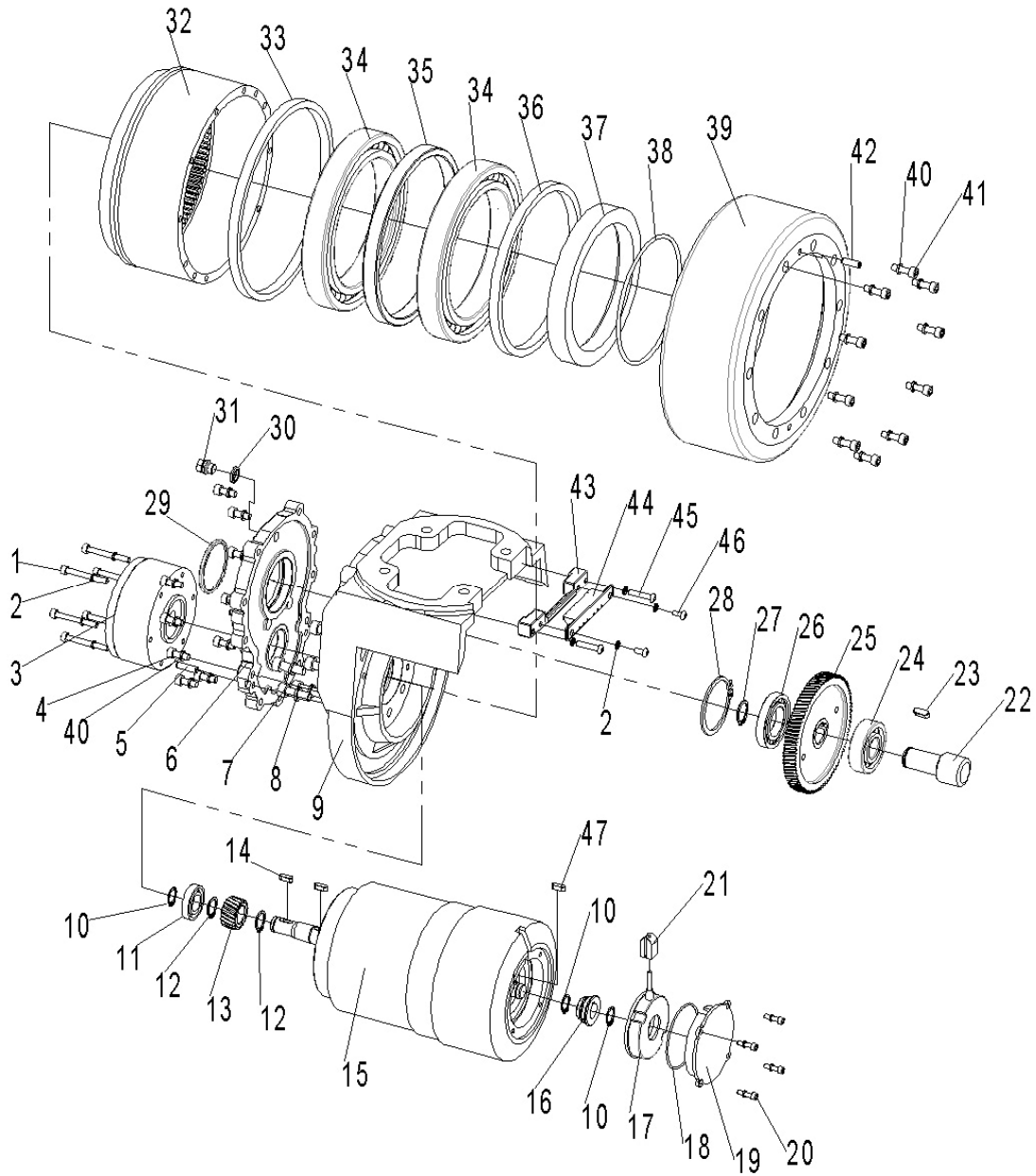

Fig.32 Drive system(manual steering)

No.	Art No.	Description	Qty.	Note	Standard
1	9000007773	Drive wheel	1	∅252	
2	9000008142	Welded long axle bearing	1		

3	0000023184	Bolt	4	M12×40	GB/T5783
4	0000025024	Washer	8	12	GB/T93
5	9000008134	Limit block	2		
6	0000023158	Bolt	1	M10×30	GB/T70.1=ISO4762
7	0000025032	Washer	4	12	GB/T95
8	0000023082	Bolt	4	M12×35	GB/T70.1=ISO4762
9	0000023088	Bolt	4	M10×25	GB/T70.1=ISO4762
10	0000023006	Washer	8	10	GB/T93
11	9000008145	Welded fixing frame	1		
12	0000026015	Circlip	1	Ø55	GB/T894.1
13	0090000456	Bearing	1	61811-Z	GB/T276=ISO3290
14	9000008149	Welded wheel frame	1		
15	0000027085	Bearing	1	51111	GB/T301
16	0000026013	Circlip	4	Ø25	GB/T894.1
17	9000008152	Adjusting block	4		
18	9000008153	Roller	4		
19	0090000457	Screw	4	M12×20	GB/T77
20	9000008147	Spring guide	2		
21	2000231002	Spring	2	Ø7×Ø40×	
22	2000208001	Spring guide bushing	2		
23	9000008148	Spring pressing cover	2		
24	2000223001	Bolt	2	M10×180	
25	9000008144	Adjusting stud	2		
26	9000008143	Dust cover	1		
27	0000026020	Circlip	1	Ø70	GB/T893.1
28	9000008151	Nylon guide sleeve	1		
29	0000030002	Oil cup	1	M6	JB/T7940.1
30	9000008150	Welded guide sleeve	1		
31	0000025002	Washer	4	10	GB/T95
32	0000023038	Bolt	4	M10×25	GB/T5783
33	9000008405	Drive motor wiring harness	1		
①	9000008146	Spring components	2		

Fig. 33 Drive wheel(43EL)



**Fig.33 Drive wheel(43EL)**

No.	Art No.	Description	Qty.	Note	Standard
1	0090000101	Screw	6	M5×45	GB/T70.1=ISO4762
2	0000025012	Washer	10	5	GB/T93
3	9000008846	Brake	1		
4	0000023040	Screw	11	M6×16	GB/T70.1=ISO4762
5	0000028175	Dowel pin	2	6×22	GB/T120.2
6	9000008847	Gear box cover	1		
7	0000023047	Screw	5	M8×25	GB/T70.1=ISO4762
8	0000025012	Washer	5	8	GB/T93
9	9000008848	Gear box	1		
10	0000026004	Circlip	3	15	GB894.1
11	0000022232	Oil seal	1	17×35×7	GB/T9877
12	0000026005	Circlip	2	17	GB/T894.1
13	9000008849	Small gear	1		
14	0000036002	Flat key	2	A5×14	GB/T1096
15	9000008850	AC motor	1		
16	9000008851	Shaft sleeve	1		
17	9000008852	Sensor	1		
18	0000022002	O seal ring	1	6.3×1.8	GB/T3452.1
19	9000008853	Protective cover	1		
20	0090000473	Screw	4	M4×10	GB/T70.3
21	9000008854	Bushing	1		
22	9000008855	Gear shaft	1		
23	0000036001	Flat key	1	A6×16	GB/T1096
24	0000027067	Bearing	1	6304	GB/T276=ISO3290
25	9000008856	Big gear	1		
26	0090000285	Bearing	1	6006	GB/T276=ISO3290
27	0000026003	Circlip	1	20	GB/T894.1
28	0000026007	Circlip	1	55	GB/T893.1

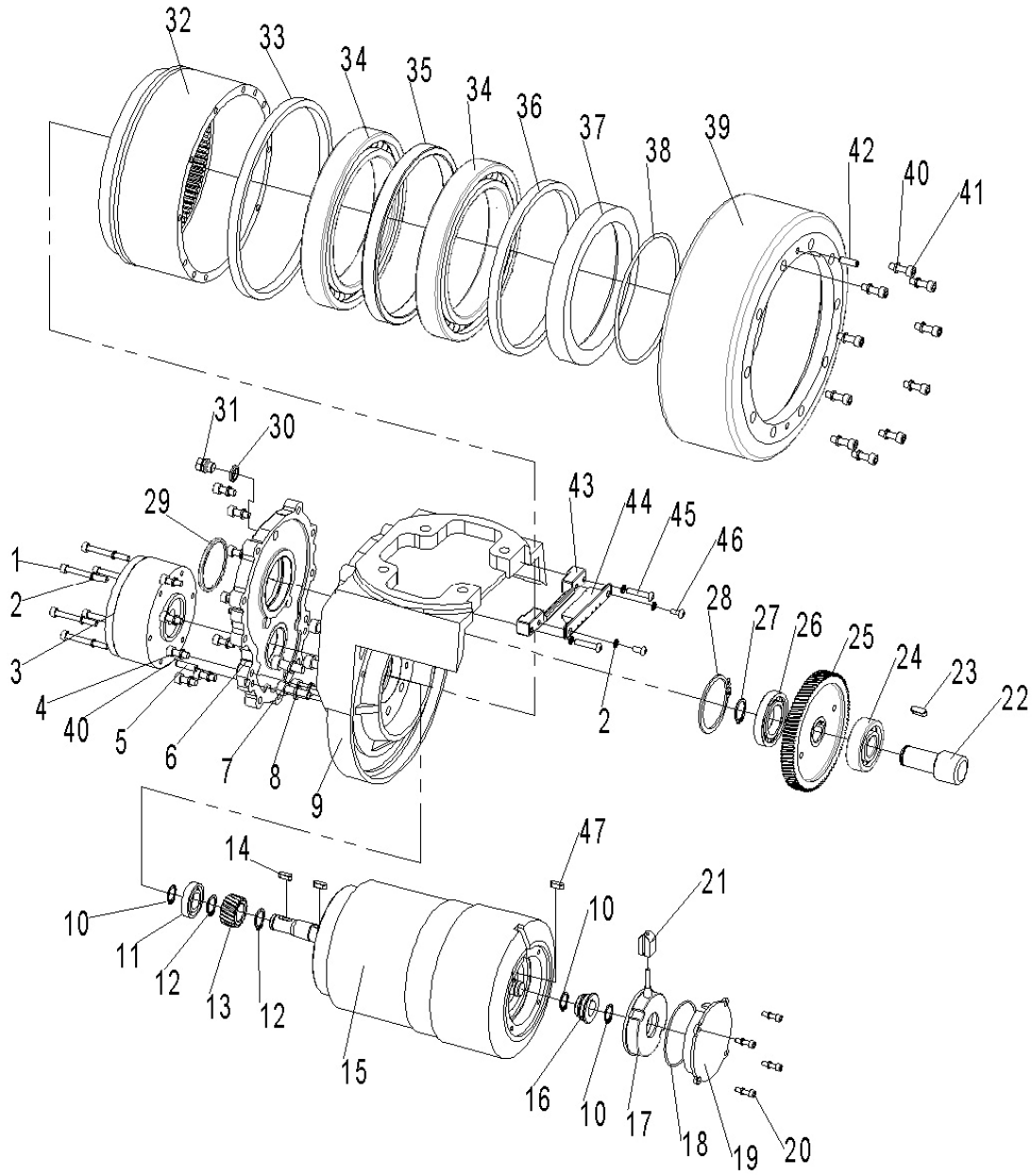

**Fig.33 Drive wheel(43EL)**

29	9000008857	Cover	1		JB/T982
30	0000025021	Washer	1	10	
31	2000303001	Vent plug	1	10	
32	9000008858	Internal gear	1		GB/T9877
33	0000022007	Oil seal	1	188×202×10	GB/T276=ISO3290
34	0090000453	Bearing	2	61926-2LS	
35	9000008859	Bushing	1		GB/T9877
36	0090000178	Oil seal	1	160×175×10	
37	9000008860	Oil seal seat	1		GB/T3452.1
38	0090000454	O ring	1	125×3.55	
39	9000008861	Drive wheel	1		GB/T93
40	0000025006	Washer	21	6	GB/T70.1=ISO4762
41	0000023062	Screw	10	M6×20	GB/T119.1
42	0000028177	Dowel pin	2	6×20	
43	9000008862	Down wire holder	1		
44	9000008863	Upper wire holder	1		GB/T70.2=ISO7380
45	0000023065	Screw	2	M5×25	GB/T70.2=ISO7380
46	0090000041	Screw	2	M5×10	GB/T1096
47	0090000475	Flat key	1	A 5×10	JB/T982

Fig. 34 Drive system(electrical steering)

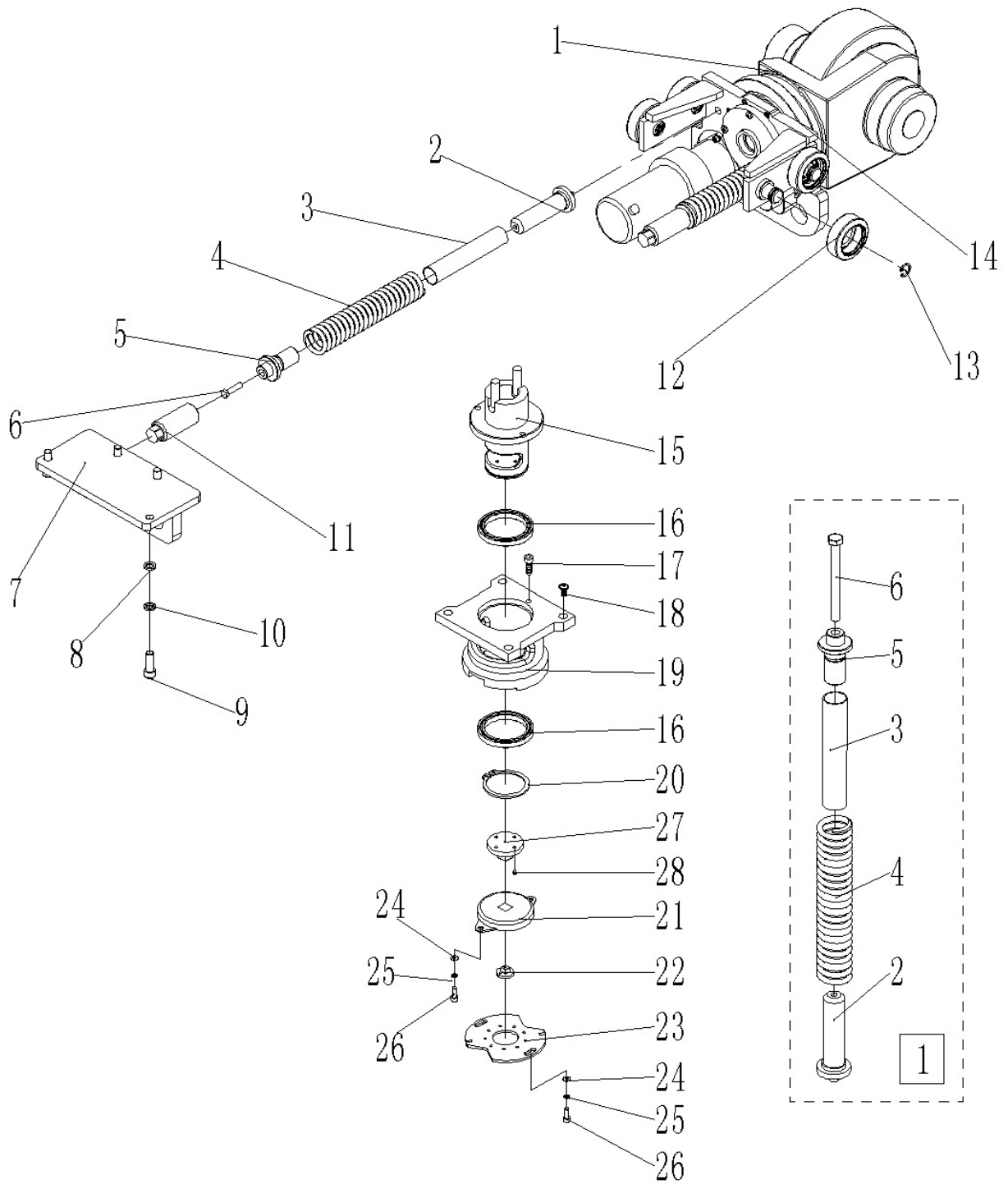
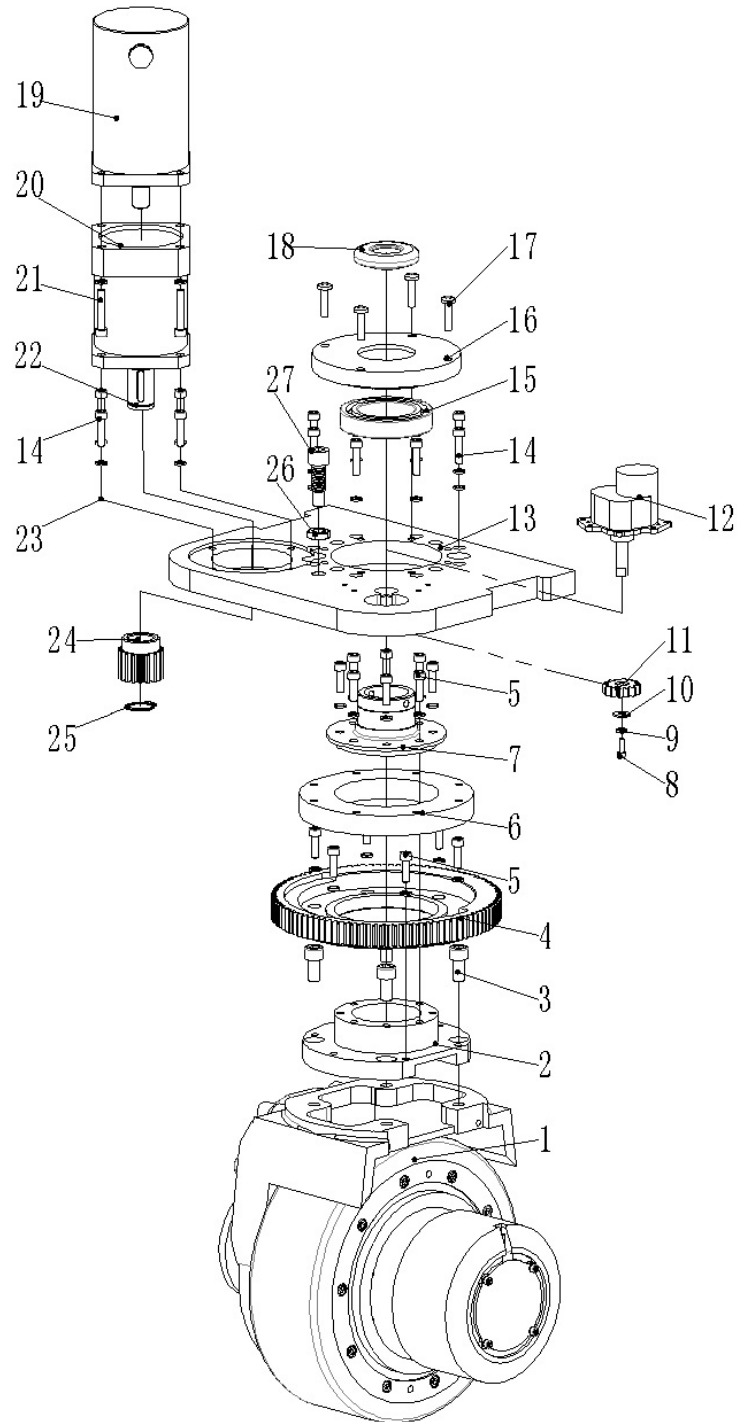



**Fig.34 Drive system(electrical steering)**

No.	Art No.	Description	Qty.	Note	Standard
1	9000007777	Drive wheel	1	∅252	
2	2000212001	Spring guide	2		
3	2000208001	Spring guide bushing	2		
4	2000231002	Spring	2		
5	2000202007	Spring pressing cover	2		
6	0000023505	Bolt	2	M8×35	
7	9000008145	Welded fixing frame	1		
8	0000025032	Washer	4	12	GB/T95
9	0000023471	Screw	4	M12×35	GB/T70.1=ISO4762
10	0000025024	Washer	4	12	GB/T93
11	9000008144	Adjusting stud	2		
12	9000008153	Roller	4		
13	0000026013	Circlip	4	25	GB/T894.1
14	9000009195	Welded wheel frame	1		
15	9000007422	Welded axle seat	1		
16	9000000240	Bearing	2	65×50×7	GB/T276=ISO3290
17	0000023042	Screw	3	M6×10	GB/T70.1=ISO4762
18	0000023034	Screw	4	M10×20	GB/T70.1=ISO4762
19	9000007423	Welded fixing frame	1		
20	0000026043	Circlip	1	50	GB/T894.1
21	9000007806	Damper	1		
22	9000007421	Linking block	1		
23	9000007693	Potentiometer fixing plate	1		
24	0000023032	Washer	4	5	GB/T95
25	0000025022	Washer	4	5	GB/T93
26	0000023311	Screw	4	M5×10	GB/T70.1=ISO4762
27	9000007424	Nylon block	1		
28	0000023073	Screw	4	M4×10	GB/T70.1=ISO4762
①	9000008146	Spring components	2		

Fig. 35 Drive wheel(23EL)



**Fig.35 Drive wheel(23EL)**

No.	Art No.	Description	Qty.	Note	Standard
1	9000007773	Drive wheel	1		
2	9000009200	Pivoting support	1		
3	0000023034	Screw	4	M10×20	GB/T70.1=ISO4762
4	9000009201	Steering big gear	1		
5	0000023020	Screw	24	M6×20	GB/T70.1=ISO4762
6	9000009202	Pivoting support	1		
7	9000009203	Bearing seat	1		
8	0000023056	Screw	1	M4×12	GB/T70
9	0000025009	Washer	1	4	GB/T93
10	0000025133	Washer	1	5	GB/T96
11	9000009204	Gear for sensor	1		
12	9000009205	Steering sensor	1		
13	9000009195	Welded wheel frame	1		
14	0000023030	Screw	12	M6×25	GB/T70
15	0000027065	Bearing	1	6010	GB/T276=ISO3290
16	9000009206	End cap	1		
17	0000023277	Screw	4	M6×25	GB/T818=ISO7045
18	9000009207	Rubber sleeve	1		
19	9000009208	Steering motor	1	200W24 V	
20	9000009209	Steering motor gear box	1		
21	0000023090	Screw	4	M6×35	GB/T70
22	0090000118	Flat key	1	6×28	GB/T1096
23	0000025010	Washer	51	6	GB/T93
24	9000009210	Steering small gear	1		
25	0000026040	Circlip	1	22	GB/T894.1-1986
26	0000024116	Nut	1	M12	GB/T6172.1
27	9000009211	Screw	1		

Fig. 36 Instrument components

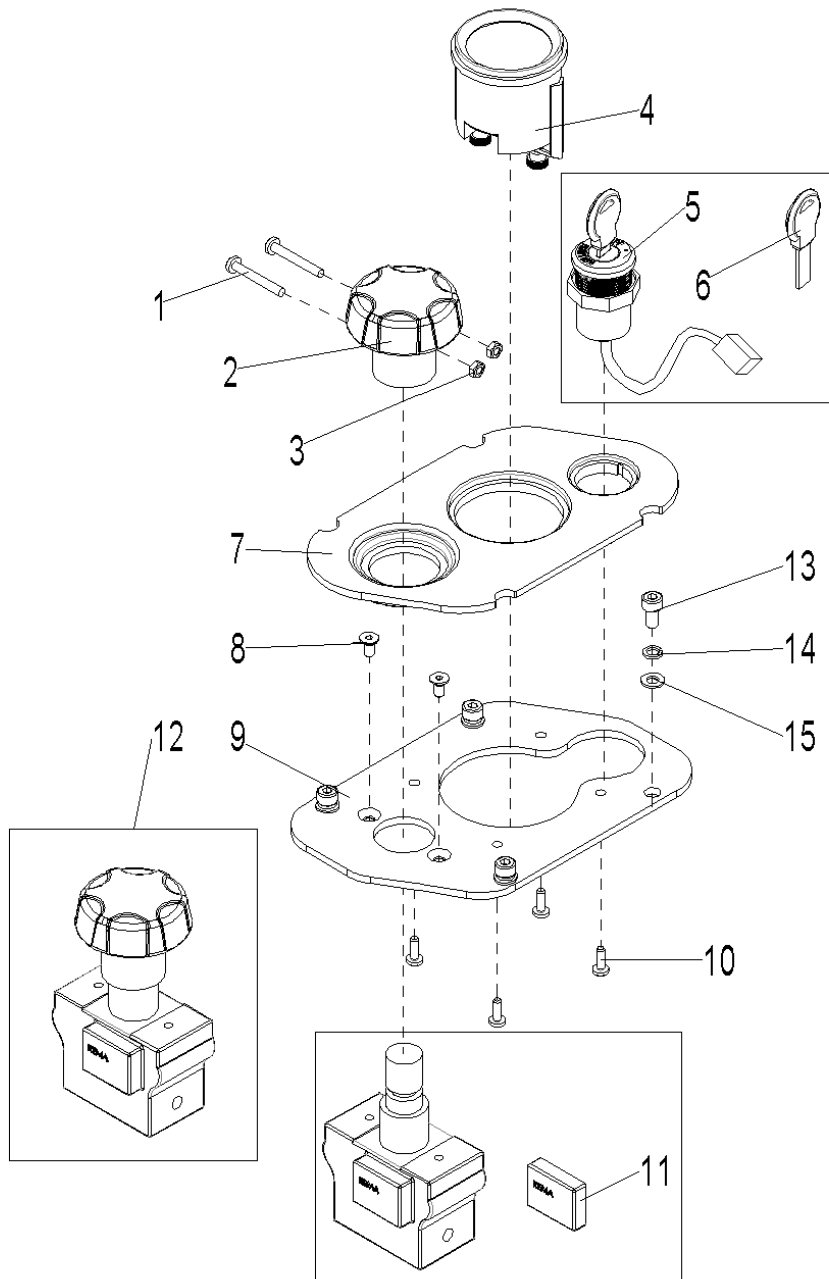

**Fig.36 Instrument Components**

No.	Art No.	Description	Qty.	Note	Standard
1	0000023685	Screw	2	M3×25	GB/T818=ISO7045
2	9000008516	Emergency button head	1		
3	0000024002	Nut	2	M3	GB/T6170
4	1000434025	Indicator	1	CURTIS 803	
5	9000008326	Key switch	1	LKS-101A	
6	9000008519	Key	1		
7	9000007938	Plastic plate	1		
8	0000023215	Screw	2	M5×10	GB/T70.3
9	9000007939	Fixing plate	1		
10	0090000272	Screw	4	M4×12	GB/T6560
11	9000008517	Micro switch	1		
12	9000008515	DC power switch	1	ZDK32-350	
13	0000023053	Screw	3	M6X12	GB/T70.1=ISO4762
14	0000025010	Washer	3	6	GB/T93
15	0000023055	Washer	3	6	GB/T95

Fig. 37 Tiller arm assembly

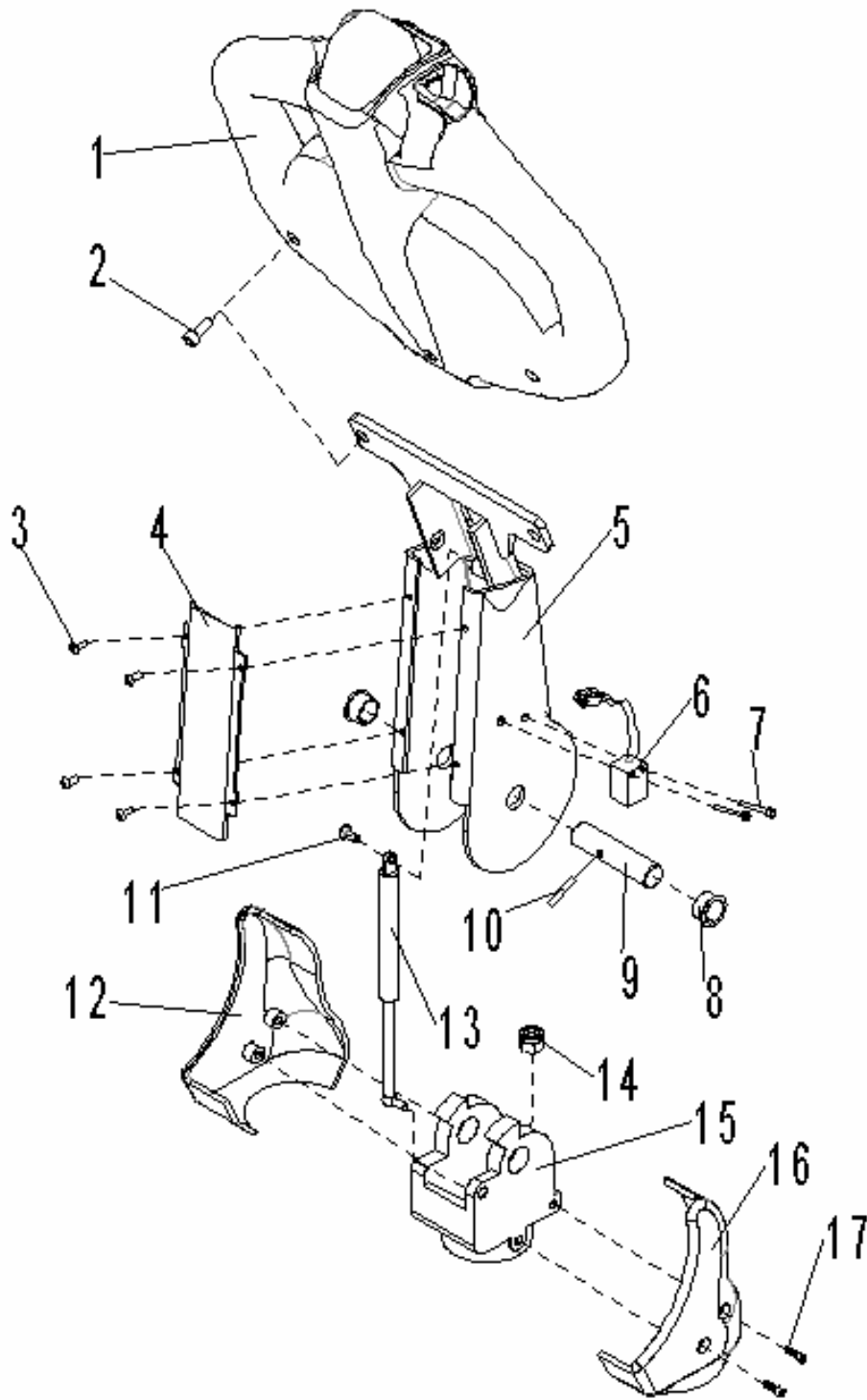

**Fig.37 Tiller arm assembly**

No.	Art No.	Description	Qty.	Note	Standard
1	1100100001	Canbus control tiller	1	C 94300-90	
2	0000023232	Bolt	2	M8×25	GB/T5783
3	1000123003	Screw	4	M4×8	GB/T70.2=ISO7380
4	9000007926	Cover board	1	with platform	
	9000009961	Long cover board	1	without	
5	9000007925	Welded tiller arm	1	with platform	
	9000009962	Welded long tiller arm	1	without	
6	9000008327	Proximity switch	1	NBN5-F7-E2	
7	0000023075	Screw	2	M3×20	GB/T70.1=ISO4762
8	1000113001	Shoulder harness	2	∅17×∅19×11	
9	9000007928	Tiller axle	1		
10	0000028003	Dowel pin	1	∅4×24	GB/T879.1
11	0000023044	Screw	1	M8×20	
12	9000007930	Left tiller cover	1		
13	1010121001	Air spring	1	400N	
14	0000023005	Lock nut	2	M10	GB/T889.1=ISO7040
15	9000007929	Tiller seat	1		
16	9000007931	Right tiller cover	1		
17	0000023519	Screw	4	M6×10	GB/T70.2=ISO7380

Fig. 38 Tiller head

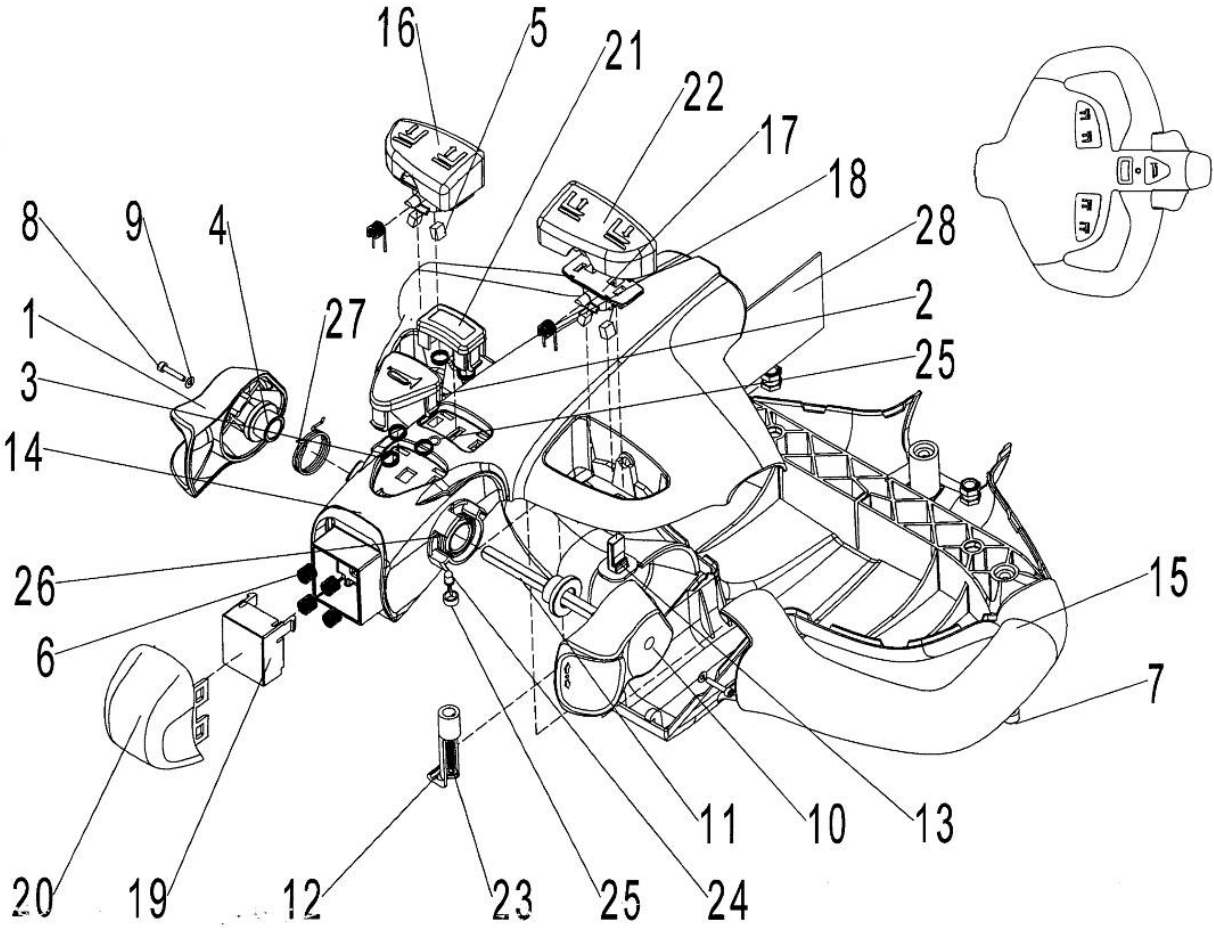



**Fig.38 Tiller head**

No.	Art No.	Description	Qty.	Note	Standard
1	1010114001	Left driving button	1		
2	1000114015	Horn button	1		
3	1000131009	Spring for horn button	5		
4	1000113004	Bushing for camshaft	2		
5	1000137001	Magnet	4		
6	1000131010	Spring for emergency button	4		
7	0000023058	Screw	3	M6×10	GB/T70.1=ISO4762
8	0000023057	Screw	2	M3×16	GB/T70.1=ISO4762
9	0000025017	Washer	2	3	GB/T95
10	1010114003	Right driving button	1		
11	1000107002	Shaft for driving button	1		
12	1000137002	PCB terminal	1		
13	1000134005	Pressure sensor	2		
14	1000103012	Upper part of handle	1		
15	1000103013	Under part of handle	1		
16	1000114017	Left elevator button	1		
17	1000137003	Magnet assembly seat	2		
18	1000131011	Torsional spring	2		
19	1000114018	Spring fixing plate for emergency button	1		
20	1000114020	Emergency button	1		
21	1000114021	Cover for option switch	1		
22	1000114022	Right elevator button	1		
23	0000023060	Screw	1	ST4.2×25	GB/T845
24	1000134006	LED bi-color light	1		
25	1000103014	Seat for LED bi-color light	1		
26	1000131012	Torsional spring for left driving button	1		
27	1000131013	Torsional spring for right driving button	1		
28	1100135001	PCB	1		

## Easy worn parts list

No.	Art No.	Description	Qty.	Fig./Position	Note
1	9000007780	Air spring	1	Fig.4/5	Protective arm
2	9000007897	Positioning spring	1	Fig.4/9	
3	9000007799	Shoulder harness	4	Fig.5/3	Foldable platform
4	2000421001	Air spring	1	Fig.5/6	
5	9000008897	Suspension components	2	Fig.5/27	
6	0000027001	Bearing 6204	4	Fig.8/15	Steering wheel
7	2210416001	Castor	2	Fig.8/17	
8	9000008896	Wheel set	2	Fig.8/19	
9	2000416002	Load roller	4	Fig.9/4	Load wheel
10	0000027001	Bearing 6204	8	Fig.9/5	
11	9000008895	Wheel set	4	Fig.9/7	
12	9000007782	Spring buckle	8	Fig.10/9	Mast assembly
				Fig.11/10	
				Fig.12/21	
13	1000434040	Fuse 10A	1	Fig.13/3	Electronic control assembly(manual steering)
14	1020434001	Fuse 200A	1	Fig.13/14	
15	2210434004	Fuse 150A	1	Fig.13/15	
16	1020434001	Fuse 200A	1	Fig.14/14	Electronic control assembly(electrical steering)
17	2210434004	Fuse 150A	1	Fig.14/15	
18	1000434040	Fuse 10A	1	Fig.14/18	
19	3042434014	Fuse 15A	1	Fig.14/19	
20	9000009926	Dust ring 40x48x5/6.5	1	Fig.22/2	Cylinder(PS B15DTwo-Stage-Mast Lift)
21	9000009927	Support ring for hole 40X44X10	1	Fig.22/3	
22	9000009932	O ring 44.4X3.1	1	Fig.22/6	
23	9000009933	Support ring for hole 45X50X10	1	Fig.22/7	
24	9000009934	O ring 24.4X3.1	2	Fig.22/8	
25	9000009178	Y ring for hole 40X50X6/7	1	Fig.22/9	
26	9000009943	Cylinder seal components	1	Fig.22/1	
27	9000009926	Dust ring 40x48x5/6.5	1	Fig.24/2	Cylinder(PS B15F)

28	9000009927	Support ring for shaft 40X44X10	1	Fig.24/3	Two-Stage-Mast Full-Free-Lift)
29	9000009932	O ring 44.4X3.1	1	Fig.24/6	
30	9000009933	Support ring for hole 45X50X10	1	Fig.24/7	
31	9000009934	O ring 24.4X3.1	2	Fig.24/8	
32	9000009178	Y ring for hole 40X50X6/7	1	Fig.24/9	
33	9000009944	Cylinder seal components	1	Fig.24/11	
34	0000022029	O ring 50×3.1	1	Fig.26/3	Cylinder(PS B15H Three-Stage-Mast Lift)
35	9000009182	Support ring for hole 46×50×15	1	Fig.26/5	
36	9000009178	Y ring for hole 40×50×6/7	1	Fig.26/6	
37	9000009169	Dust ring 40×48×5/6.5	1	Fig.26/7	
38	9000009956	Cylinder seal assembly	1	Fig.26/11	
39	9000009075	Dust ring 32X40X5/6.5	1	Fig.29/2	Cylinder(PS B15Z Three-Stage-Mast Full-Free-Lift)
40	0090000487	O ring 38X3.1	1	Fig.29/3	
41	9000009079	Seal ring 32X42X6/7	1	Fig.29/4	
42	9000008953	Seal ring 32X42.7X4.2	1	Fig.29/5	
43	9000008954	Support ring for shaft 32X36X5	1	Fig.29/6	
44	0000022029	O ring 50X3.1	2	Fig.29/7	
45	9000008955	Support ring for hole 36X40X10	2	Fig.29/14	
46	9000009957	Cylinder seal assembly	1	Fig.29/11	
47	9000009076	Dust ring 45X53X5/6.5	1	Fig.30/2	Middle cylinder(PS B15Z Three-Stage-Mast Full-Free-Lift)
48	9000009078	Seal ring for shaft 45X55X6/7	1	Fig.30/3	
49	9000008957	Circlip 55X60X1.5	1	Fig.30/5	
50	0000022055	O ring 60X3.1	1	Fig.30/6	
51	9000008956	Support ring for hole 48X52X15	1	Fig.30/11	
52	9000009958	Cylinder seal kit	1	Fig.30/11	
53	9000003582	Carbon brush(components)	1	Fig.27/2	Pump station
				Fig.31/2	
54	0000022002	O seal ring	1	Fig.35/18	Drive wheel
55	1010121001	Air spring	1	Fig.37/13	Tiller arm assembly
56	1000113001	Shoulder harness	2	Fig.37/8	